



**INSTALLATION, OPERATION AND  
MAINTENANCE INSTRUCTIONS**



**Packaged Rooftop Units  
R410A & R454B**

**50/48 UC-(V)/UP-(V) 025-220**

## Contents

<b>1</b>	<b>- INTRODUCTION.....</b>	<b>4</b>
1.1	- Check equipment received.....	4
1.2	- Installation safety considerations.....	4
1.3	- Equipment and components under pressure.....	5
1.4	- Maintenance safety considerations.....	5
1.5	- Repair safety considerations.....	7
<b>2</b>	<b>- MOVING AND PLACING THE UNIT.....</b>	<b>8</b>
2.1	- Moving.....	8
2.2	- Placing the unit.....	8
2.3	- Checks before system start-up.....	15
<b>3</b>	<b>- INSTALLATION.....</b>	<b>15</b>
3.1	- Unit base frame.....	15
3.2	- Sensor connection and location.....	16
3.3	- Ductwork.....	16
3.4	- Condensate and rainwater drainage.....	18
<b>4</b>	<b>- DIMENSIONS, CLEARANCES, MM.....</b>	<b>19</b>
4.1	- Multiple Rooftop Installation.....	28
<b>5</b>	<b>- PHYSICAL DATA.....</b>	<b>29</b>
<b>6</b>	<b>- ELECTRICAL DATA.....</b>	<b>30</b>
<b>7</b>	<b>- APPLICATION DATA.....</b>	<b>31</b>
7.1	- Air filter replacement.....	31
7.2	- Fan performances, 50/48 UC-(V)/UP-(V) 025.....	32
7.3	- Fan performances, 50/48 UC-(V)/UP-(V) 035.....	32
7.4	- Fan performances, 50/48 UC-(V)/UP-(V) 045.....	32
7.5	- Fan performances, 50/48 UC-(V)/UP-(V) 055.....	33
7.6	- Fan performances, 50/48 UC-(V)/UP-(V) 065.....	33
7.7	- Fan performances, 50/48 UC-(V)/UP-(V) 075.....	33
7.8	- Fan performances, 50/48 UC-(V)/UP-(V) 090.....	34
7.9	- Fan performances, 50/48 UC-(V)/UP-(V) 105.....	34
7.10	- Fan performances, 50/48 UC-(V)/UP-(V) 125.....	35
7.11	- Fan performances, 50/48 UC-(V)/UP-(V) 140.....	35
7.12	- Fan performances, 50/48 UC-(V)/UP-(V) 160.....	36
7.13	- Fan performances, 50/48 UC-(V)/UP-(V) 190.....	36
7.14	- Fan performances, 50/48 UC-(V)/UP-(V) 220.....	37
7.15	- Pressure Drops (Pa).....	38
7.16	- Air Flow Rate Limits.....	41
7.17	- Indoor fan air flow adjustment.....	41
<b>8</b>	<b>- ELECTRICAL CONNECTIONS.....</b>	<b>41</b>
8.1	- Control box.....	41
8.2	- Power supply.....	41
8.3	- Voltage phase imbalance (%).....	41
8.4	- Recommended wire sections.....	42
8.5	- Field control wiring.....	42
8.6	- Power supply.....	42
<b>9</b>	<b>- START-UP.....</b>	<b>42</b>
9.1	- Preliminary checks.....	42
9.2	- Actual start-up.....	43
9.3	- Defrost cycle.....	43
<b>10</b>	<b>- MAJOR SYSTEM COMPONENTS.....</b>	<b>43</b>
10.1	- Compressors.....	43
10.2	- Lubricant.....	43
10.3	- Condensers.....	43
10.4	- Outdoor fans.....	44
10.5	- Indoor fans.....	44
10.6	- Electronic expansion valve (EXV).....	44
10.7	- Moisture indicator.....	44
10.8	- Filter drier.....	44
10.9	- Refrigerant.....	44
10.10	- Four-way valve (50/48 UP-(V) heat pumps).....	44

10.11- Sensors .....	44
10.12- High-pressure safety switch .....	44
10.13- Variable Frequency Driver (VFD) .....	45
10.14- R-454B Refrigerant leak detector (standard) .....	45
<b>11 - OPERATING LIMITS .....</b>	<b>45</b>
<b>12 - GAS HEATING (48 UC-(V)/UP-(V) ONLY) .....</b>	<b>45</b>
12.1 - Introduction .....	45
12.2 - Preliminary checks before start-up.....	46
12.3 - Safety instructions.....	46
12.4 - Installation of the gas heating module.....	46
12.5 - Commissioning.....	48
12.6 - Combustion Analysis.....	49
12.7 - Operating sequence.....	50
12.8 - Maintenance operations.....	51
12.9 - Control of PCH heater.....	52
<b>13 - OPTION .....</b>	<b>54</b>
13.1 - Electric heaters .....	54
13.2 - Hot-water coil .....	54
13.3 - Economizer options (Thermostatic or Enthalpic) .....	54
13.4 - Manual outside air damper.....	56
13.5 - Economizer with Electric Pre-Heater (Thermostatic or Enthalpic) .....	57
13.6 - Power exhaust option.....	57
13.7 - Return fan .....	60
13.8 - Dirty filter detection option.....	66
13.9 - Smoke detector .....	66
13.10 - Fire thermostat.....	66
13.11 - Thermodynamic Energy Recovery (THR).....	66
13.12 - Energy Recovery Module (ERM) .....	67
13.13 - Energy meter.....	76
13.14 - UV-C lamp.....	76
13.15 - Humidity control .....	76
<b>14 - ACCESSORIES .....</b>	<b>76</b>
14.1 - Roofcurbs.....	76
14.2 - Leak Detection (R410A).....	76
14.3 - Dirty Filter Detection.....	77
14.4 - CO <sup>2</sup> Sensor .....	77
<b>15 - STANDARD MAINTENANCE.....</b>	<b>77</b>
15.1 - Maintenance program .....	77
15.2 - Maintenance instructions .....	77
15.3 - Level 1 maintenance.....	77
15.4 - Level 2 maintenance.....	78
15.5 - Level 3 (or higher) maintenance .....	78
15.6 - Tightening torques for main electrical connections .....	79
15.7 - Tightening torques for the main bolts and screws.....	79
15.8 - Indoor/outdoor coils.....	80
15.9 - Refrigerant volume.....	80
15.10- Servicing recommendations.....	81
15.11- Final recommendations.....	81
15.12- Troubleshooting chart.....	81
<b>16 - START-UP CHECKLIST FOR 50/48 UC-(V)/UP-(V) ROOFTOP UNITS (USE FOR JOB FILE) .....</b>	<b>82</b>
<b>17 - GAS HEATING SECTION .....</b>	<b>85</b>

**NOTES FOR 48 SERIES UNITS FITTED WITH A GAS BURNER**

**IMPORTANT:** The appliance must be installed in accordance with local safety codes and regulations and is intended for outdoor use only.

Please read the manufacturer’s instructions carefully before starting this unit.

**CAUTION:** Before installation, check that the local distribution conditions, type of gas and available pressure, and the power supply and adjustments of the appliance are correct.

The drawings in this document are for illustrative purposes only and is not part of any offer for sale or contract.

## 1 - INTRODUCTION

Prior to the initial start-up of the 50/48 UC-(V)/UP-(V) units, the people involved should be thoroughly familiar with these instructions and the specific project data for the installation site. The 50/48 UC-(V)/UP-(V) packaged rooftop units are designed to provide a very high level of safety and reliability making installation, start-up, operation and maintenance easier and more secure. They will provide safe and reliable service when operated within their application range.

- 50/48UC-(V) R410A and R-454B series: Units for cooling only operation.
- 50/48UP-(V) R410A and R-454B series: Units for heat pump operation.

They are designed for an operating life of 15 years by assuming a 75% utilization factor; that is approximately 100,000 operating hours.

The procedures in this manual are arranged in the sequence required for machine installation, start-up, operation and maintenance.

Be sure you understand and follow the procedures and safety precautions contained in the instructions supplied with the machine, as well as those listed in this guide, such as: protective clothing such as gloves, safety glasses, safety shoes and appropriate tools, and suitable qualifications (electrical, air conditioning, local legislation).

To find out, if these products comply with European directives (machine safety, low voltage, electromagnetic compatibility, equipment under pressure, etc.) check the declarations of conformity for these products.

After manufacturing, all units are charged with the selected refrigerant: R-410A or R-454B, and are tested at the factory, verifying the correct operation of all their components within the operating range for which they are intended.

Caution: If the unit contains refrigerant R-454B (A2L fluid) specific transport safety standards must be complied with:

- Road transport: UN 3358 Refrigerating machines, containing flammable, non-toxic, liquefied gas. Transport through the Eurotunnel and through tunnels with category D and E is not permitted.
- Maritime transport: IMDG (International Maritime Dangerous Goods) code: DS 291.
- Air transport: not permitted.

The container must be identified according to UN 3358. Do not approach the container or truck in the presence of an open flame, an electrical power source, a mobile phone, or any other heat source.

Important: the type of refrigerant included in the unit can be consulted on the name plate.

### 1.1 - Check Equipment Received

- Inspect the unit for damage or missing parts. If damage is detected, or if shipment is incomplete, immediately file a claim with the shipping company.
- Confirm that the unit received is the one ordered. Compare the name plate data with the order.
- The name plate is attached to the unit on the outside on

one of the unit sides and also on the inside electrical panel door

- The unit name plate must include the following information:
  - Model number - size
  - CE marking
  - Serial number
  - Year of manufacture and pressure and leak tightness test date
  - Type of Refrigerant used (R410A or R454B)
  - Refrigerant charge per circuit
  - PS: Min/max allowable pressure (high and low pressure side) - see chapter 11
  - TS: Min/max allowable temperature (high and low pressure side) - see chapter 11
  - Pressure switch cut-out pressure
  - Unit leak test pressure
  - Voltage, frequency, number of phases
  - Maximum current input
  - Maximum power input
  - Unit net weight
- Confirm that all options ordered for on-site installation have been delivered, are complete and undamaged.

The unit must be checked periodically during its whole operating life for possible damage of the insulation (thermal, acoustic) to ensure that no shocks (handling accessories, tools, etc.) have damaged it. If necessary, the damaged insulation parts must be repaired or replaced. See also chapter "Maintenance"

### 1.2 - Installation Safety Considerations

After the unit has been received, and before it is started up, it must be inspected for damage. Check that the refrigerant circuits are intact, especially that no components or pipes have shifted or been damaged (e.g. following a shock). If in doubt, carry out a leak tightness check. If damage is detected upon receipt, immediately file a claim with the shipping company or repair.

The unit must be installed in a place that is not accessible to the public or protected against access by non-authorized persons.

These units are designed to be installed outdoors, in a free field type, well ventilated area. It is user's responsibility to ensure that the final installation respects all local, national and international regulations.

The compressor and line surfaces can reach temperatures above 100°C causing burns to the body. In the same fashion, under certain conditions these surfaces can reach very cold temperatures that can cause freezing risks.

No combustible matter should be placed within 6.5 metres of the unit

The unit should not be installed and stored in an explosive

atmosphere. Do not remove the skid or the packaging until the unit is in its final position.

If it is necessary to store the unit for a period of time before its installation, the following recommendations should be followed:

- Do not remove the protective packaging and the transport supports. The unit packed with plastic protective film should not remain exposed to the sun for long, as prolonged exposure of the protective film can deteriorate the unit's paint.
- Store the unit on a flat and horizontal surface.
- It is highly recommended to store the unit in a dry place and protected from the weather.
- Supplied accessories must be stored in a dry and clean place for future unit assembly.
- The unit should always be stored under the following environmental conditions:

- Minimum ambient temperature: -20°C

- Maximum ambient temperature: 52°C

- Maximum relative humidity: 95% (to avoid condensation)

These units can be moved with a forklift truck, as long as the forks are positioned in the right place and direction on the unit.

The units can also be lifted with slings, using only the designated lifting points marked on the unit (labels on the chassis and a label with all unit handling instructions are attached to the unit).

Use slings with the correct capacity, and always follow the lifting instructions on the certified drawings supplied for the unit.

This unit is designed for ducted installation (indoor air supply and return). If ducts are not used the installer must place a protection grille in the supply and return.

Safety is only guaranteed, if these instructions are carefully followed. If this is not the case, there is a risk of material deterioration and injuries to personnel.

These units are not designed to be lifted from above.

All precautions concerning handling of refrigerant must be observed in accordance with local regulations.

Accumulation of refrigerant in an enclosed space can displace oxygen and cause asphyxiation or explosions.

Inhalation of high concentrations of refrigerant is harmful and may cause heart irregularities, unconsciousness, or death. Refrigerant is heavier than air and reduces the amount of oxygen available for breathing. These products cause eye and skin irritation. Decomposition products can be hazardous.

### 1.3 - Equipment and Components Under Pressure

These products incorporate equipment or components under pressure, manufactured by Carrier or other manufacturers.

We recommend that you consult your appropriate national trade association or the owner of the equipment or components under pressure (declaration, re-qualification, retesting, etc.). The characteristics of this equipment/these

components are given on the nameplate or in the required documentation, supplied with the products.

The units are intended to be stored and operate in an environment where the ambient temperature must not be less than the lowest allowable temperature indicated on the nameplate.

Do not introduce high static and dynamic pressure compared with the existing operating pressures - either service or test pressures in the refrigerant circuit.

### 1.4 - Maintenance Safety Considerations

Carrier recommends the following drafting for a logbook (the table below should not be considered as reference and does not involve Carrier responsibility):

Intervention		Name of the Commissioning Engineer	Applicable National Regulations	Verification Organism
Date	Operation*			

\*Maintenance, repairs, regular verifications (EN 378), leakage, etc.

Engineers working on the electric or refrigeration or gas heating components must be authorized, trained and fully qualified to do so (e.g. electricians trained and qualified in accordance with IEC 60364 Classification BA4).

All refrigerant circuit work must be carried out by a trained person, fully qualified to work on these units. They must have been trained and be familiar with the equipment and the installation. All welding operations must be carried out by qualified specialists.

These units use high pressure R410A or R454B refrigerant (the unit operating pressure is above 40 bar, the pressure at 35 °C air temperature is 50% higher than R22). Special equipment must be used when working on the refrigerant circuit (pressure gauge, charge transfer, etc.).

According to EN 378-1, R410A belongs to the A1 group, i.e. with high safety both in the mix and also in the case of a leak.

Although it is not flammable, keep them away from open flames (e.g. cigarettes) as temperatures of over 300°C cause their vapours to break down and form phosgene, hydrogen fluoride, hydrogen chloride and other toxic compounds. These compounds may produce severe physiological consequences if accidentally inhaled or swallowed.

In case of a leak:

- To detect leaks, an electronic leak detector, an ultraviolet lamp or soapy water must be used. Flame detectors do not help.
- If a leak occurs or if the refrigerant becomes contaminated (e.g. by a short circuit in a motor) remove the complete charge using a specific recovery unit for R-410A.
- The refrigerant must be stored in mobile certified containers.
- Repair the leak detected and recharge the circuit with the total refrigerant charge, as indicated on the unit name plate. Only charge liquid refrigerant at the liquid line.

According to EN 378-1, R454B belongs to the A2L group,

that is, non-toxic and low flammability, so it only requires minimal precautions for a completely safe operation.

Always use tools qualified for A2L refrigerants according to EN 378 or ISO 817.

Risk of flammability: with A2L refrigerant, always use an A2L refrigerant detector when near the unit. Default potentially flammable zone is 0.6 metres around the unit.

Never apply an open flame or live steam to a refrigerant container. Dangerous overpressure can result. In case of combustion of refrigerant, do not clean combustion byproducts with water, the mixture is highly corrosive.

In case of a leak:

- To detect leaks, an electronic leak detector, must be used.
- If a leak occurs or if the refrigerant becomes contaminated (e.g. by a short circuit in a motor) remove the complete charge using an specific recovery unit for A2L flammable refrigerants.
- The refrigerant must be stored in mobile certified containers. In this case a special bottle shall be used, with the top painted in red and threaded to the left (opposite direction to R-410A). Vacuum the recovery bottle to remove the air before filling it with flammable refrigerant.
- Use a vacuum pump, dual effect and anti-spark based on DIN 8975.
- Do not mix flammable refrigerants with other types of refrigerants in a recovery bottle. Label the recovery bottle to show that it contains a flammable substance.
- Check that there are no hazardous or combustible objects nearby and make sure that in case of fire the extinguisher is nearby. The fire extinguisher must be appropriate to the system and the refrigerant type.
- Always check that there is no refrigerant in the cooling circuit, rinsing with nitrogen before welding, and checking that the nitrogen flows correctly.

Repair the leak detected and recharge the circuit with the total refrigerant charge, as indicated on the unit name plate. Only charge liquid refrigerant at the liquid line.

Any manipulation of a refrigerant recovery valve must be carried out by a qualified and authorized engineer, observing applicable standards (e.g. during refrigerant removal). The unit must be switched off while this is done.

Equip the engineers that work on the unit as follows:

Personal Protection Equipment (PPE)*	Operations		
	Handling	Maintenance, Service	Welding or Brazing**
Protective gloves, eye protection, safety shoe, Protective clothing	x	x	x
Ear protection		x	x
Filtering respirator	x	x	x

\*We recommend to follow the instructions in EN 378-3.

\*\*Performed in the presence of A1 refrigerant according to EN 378-1.

Never work on a unit that is still energized. Never work on any of the electrical components, until the general power supply to the unit has been cut.

If any maintenance operations are carried out on the unit,

lock the power supply circuit in the open position and secure the machine upstream with a padlock.

If the work is interrupted, always ensure that all circuits are still deenergized before resuming the work.

**ATTENTION:** Even if the unit has been switched off, the power circuit remains energized, unless the unit or circuit disconnect switch is open. Refer to the wiring diagram for further details. Attach appropriate safety labels.

If any work is carried out in the fan area, specifically if the grilles or casings have to be removed, cut the power supply to the fans to prevent their operation.

#### OPERATING CHECKS:

Important information regarding the refrigerants used:

The type of refrigerant used can be consulted on the unit name plate.

This product contains fluorinated greenhouse gases covered by the Kyoto protocol.

Refrigerant type	R410A	R454B
Flammability class	A1	A2L
Global Warming Potential (GWP)	2.088	466

#### CAUTION:

1. Any intervention on the refrigerant circuit of this product should be performed in accordance with the applicable legislation. In the EU, the regulation is called F-Gas, N°517/2014.
2. Ensure that the refrigerant is never released to the atmosphere during installation, maintenance or equipment disposal.
3. The deliberate gas release into the atmosphere is not allowed
4. If a refrigerant leak is detected, ensure that it is stopped and repaired as quickly as possible.
5. Only a qualified and certified personnel can perform installation operations, maintenance, refrigerant circuit leak test as well as the equipment disposal and the refrigerant recovering.
6. The gas recovery for recycling, regeneration or destruction is at customer charge.
7. Periodic leak tests have to be carried out by the customer or by third parties. The EU regulation set the periodicity here after:

System WITHOUT Leakage detection		No Check	12 Months	6 Months	3 Months
System WITH Leakage detection		No Check	24 Months	12 Months	6 Months
Refrigerant Charge/Circuit (CO <sub>2</sub> Equivalent)		< 5 Tons	5 ≤ Charge < 50 Tons	50 ≤ Charge < 500 Tons	Charge > 500 Tons*
Refrigerant Charge (kg)	R410A (GWP: 2.088)	Charge < 2,4 kg	2,4 ≤ Charge < 23,9 kg	23,9 ≤ Charge < 239,5 kg	Charge > 239,5 kg
	R454B (GWP: 466)	Charge < 10,7 kg	10,7 ≤ Charge < 107,3 kg	107,3 ≤ Charge < 1073,0 kg	Charge > 1073,0 kg

\*From 01/01/2017, units must be equipped with a leakage detection system

8. A logbook must be established for equipments subject to periodic leak tests. It should contain the quantity and the type of refrigerant present within the installation (added and recovered), the quantity of recycled refrigerant, regenerated or destroyed, the date and output of the leak test, the designation of the operator and its belonging company, etc.
9. Contact your local dealer or installer if you have any questions.

Protection device checks:

- If no national regulations exist, check the protection devices on site in accordance with standard EN378: once a year for the high-pressure switches.

The company or organization that conducts a pressure switch test shall establish and implement a detailed procedure to fix:

- Safety measures
- Measuring equipment calibration
- Validating operation of protective devices
- Test protocols
- Recommissioning of the equipment.

Consult Carrier Service for this type of test. Carrier mentions here only the principle of a test without removing the pressure switch:

- Verify and record the set-points of pressure switches
- Be ready to switch-off the main disconnect switch of the power supply if the pressure switch does not trigger (avoid over pressure)
- Connect a calibrated pressure gauge (the values displayed on the user interface may be inaccurate in an instant reading because of the scanning delay applied in the control)
- Activate the HP quick test included in the control procedure.

**CAUTION:** If the test leads to replacing the pressure switch, it is necessary to recover the refrigerant charge, these pressure switches are not installed on automatic valves (Schrader type).”

At least once a year thoroughly inspect the protection devices. If the machine operates in a corrosive environment, inspect the protection devices more frequently.

Regularly carry out leak tests and immediately repair any leaks.

Ensure regularly that the vibration levels remain acceptable and close to those at the initial unit start-up.

Before opening a refrigerant circuit, transfer the refrigerant to bottles specifically provided for this purpose and consult the pressure gauges.

Change the refrigerant after an equipment failure, and carry out a refrigerant analysis in a specialist laboratory.

If the refrigerant circuit remains open for longer than a day after an intervention (such as a component replacement), the openings must be plugged and the circuit must be charged with nitrogen (inertia principle). The objective is to prevent penetration of atmospheric humidity and the resulting corrosion on the internal walls and on non-protected steel surfaces.

### 1.5 - Repair Safety Considerations

All installation parts must be maintained by the personnel in charge, in order to avoid deterioration and injury. Faults and leaks must be repaired immediately. The authorized technician must have the responsibility to repair the fault immediately. After each repair of the unit, check the operation of the protection devices and create a report of the parameter operation at 100%.

Comply with the regulations and recommendations in unit and HVAC installation safety standards, such as: EN 378, ISO 5149, etc.

#### RISK OF EXPLOSION



Never use air or a gas containing oxygen during leak tests to purge lines or to pressurize a machine. Pressurized air mixtures or gases containing oxygen can be the cause of an explosion. Oxygen reacts violently with oil and grease.

Only use dry nitrogen for leak tests, possibly with an appropriate tracer gas.

If the recommendations above are not observed, this can have serious or even fatal consequences and damage the installation.

Never exceed the specified maximum operating pressures. Verify the allowable maximum high and low side test pressures by checking the instructions in this manual and the pressures given on the unit name plate.

Do not unweld or flamecut the refrigerant lines or any refrigerant circuit component until all refrigerant (liquid and

vapour) and the oil have been removed from the unit. Traces of vapour should be displaced with dry nitrogen. Refrigerant in contact with an open flame can produce toxic gases.

The necessary protection equipment must be available, and appropriate fire extinguishers for the system and the refrigerant type used must be within easy reach.

Do not siphon refrigerant. Avoid spilling liquid refrigerant on skin or splashing it into the eyes. Use safety goggles and safety gloves. Wash any spills from the skin with soap and water. If liquid refrigerant enters the eyes, immediately and abundantly flush the eyes with water and consult a doctor.

The accidental releases of the refrigerant, due to small leaks or significant discharges following the rupture of a pipe or an unexpected release from a relief valve, can cause frostbites and burns to personnel exposed. Do not ignore such injuries. Installers, owners and especially service engineers for these units must:

- Seek medical attention before treating such injuries.
- Have access to a first-aid kit, especially for treating eye injuries.

We recommend to apply standard EN 378-3 Annex 3.

Never apply an open flame (blow lamp) or overheated steam (high-pressure cleaner) to the refrigerant circuit. Dangerous overpressure can result.

During refrigerant removal and storage operations follow applicable regulations. These regulations, permitting conditioning and recovery of halogenated hydrocarbons under optimum quality conditions for the products and optimum safety conditions for people, property and the environment are described in standard NF E29-795.

Refer to the certified dimensional drawings for the units.

It is dangerous and illegal to re-use disposable (non-returnable) cylinders or attempt to refill them. When cylinders are empty, evacuate the remaining gas pressure, and move them to a designated place for recovery. Do not incinerate.

Do not attempt to remove refrigerant circuit components or fittings, while the machine is under pressure or while it is running. Be sure pressure is at 0 kPa and that the unit has been shut-down and deenergised before removing components or opening a circuit.

Do not attempt to repair or recondition any safety devices when corrosion or build-up of foreign material (rust, dirt, scale, etc.) is found within the valve body or mechanism. If necessary, replace the device.

**ATTENTION:** No part of the unit must be used as a walkway, rack or support. Periodically check and repair or if necessary replace any component or piping that shows signs of damage.

Do not step on refrigerant lines. The lines can break under the weight and release refrigerant, causing personal injury.

Do not climb on a machine. Use a platform, or staging to work at higher levels.

Use mechanical lifting equipment (crane, hoist, winch, etc.) to lift or move heavy components. For lighter components, use lifting equipment when there is a risk of slipping or losing your balance.

Use only original replacement parts for any repair or component replacement. Consult the list of replacement parts that corresponds to the specification of the original equipment.

Periodically inspect all valves, fittings and pipes of the refrigerant and hydronic circuits to ensure that they do not show any corrosion or any signs of leaks.

It is recommended to wear ear defenders, when working near the unit and the unit is in operation.

Always ensure you are using the correct refrigerant type before recharging the unit.

Charging any refrigerant other than the original charge type (R410A or R454B) will impair machine operation and can even lead to a destruction of the compressors. The compressors operate with R410A or R454B and are charged with an oil.

Before any intervention on the refrigerant circuit, the complete refrigerant charge must be recovered.

## 2 - MOVING AND PLACING THE UNIT

### 2.1 - Moving

See chapter 1.2 – “Installation safety considerations”

### 2.2 - Placing the Unit

The machine must be installed in a place that is not accessible to the public or protected against access by non-authorized persons.

It is mandatory to comply with norm EN 378-3 on Safety and Environmental Requirements. Part 3: “In situ” installation and protection to people.

In case of extra-high units the machine environment must permit easy access for maintenance operations.

Always refer to the chapter “Dimensions and clearances” to confirm that there is adequate space for all connections and service operations. For the center of gravity coordinates, the position of the unit mounting holes, and the weight distribution points, refer to the certified dimensional drawing supplied with the unit.

Typical applications of these units do not require earthquake resistance. Earthquake resistance has not been verified.

**CAUTION:** Only use slings at the designated lifting points which are marked on the unit

Before placing the unit check that:

- The permitted loading at the site is adequate or that appropriate strengthening measures have been taken.
- The unit is installed level on an even surface (maximum tolerance is 5 mm in both axes).
- There is adequate space above the unit for air flow and to ensure access to the components (see dimensional drawings).
- The number of support points is adequate and that they are in the right places.
- The location is not subject to flooding



- If heavy snowfall is likely and long periods of sub-zero temperatures are normal, provision has to be made to prevent snow accumulating by raising the unit above the height of drifts normally experienced. Baffles may be necessary to deflect strong winds. They must not restrict air flow into the unit.

**CAUTION:** Before lifting the unit, check that all casing panels are securely fixed in place. Lift and set down the unit with great care. Tilting and jarring can damage the unit and impair unit operation.

If units are hoisted with rigging, it is advisable to protect coils against crushing while a unit is being moved. Use struts or a lifting beam to spread the slings above the unit. Do not tilt a unit more than 15°.

**WARNING:** Never push or lever on any of the enclosure panels of the unit. Only the base of the unit frame is designed to withstand such stresses.

General information on potentially flammable zone and ignition sources (R454B refrigerant)

The full unit, including all options & accessories that are delivered by the manufacturer, has been qualified for the use with A2L refrigerant. For that purpose, the manufacturer complies with EN 378-2§6.2.14 and defined potentially flammable zone using EN 60079-10-1 in order to identify where ignition sources must not be present. Then the manufacturer designed the machine in order that, if the unit is used the way it was designed for, there is no internal ignition source in the internal potentially flammable zone. Thus, the only residual risk is to have an ignition source introduced in the potentially flammable zone by the user. For that purpose, the manufacturer decided to represent the external potentially flammable zone where the user must not introduce ignition source. This indication is only here to help our customer to identify the limits of the flammability risk. But there is no risk of explosion linked to the used of A2L refrigerant due to the machine itself. Note (the following information is provided by the manufacturer exclusively for informational purposes. The application of the following directives relies exclusively upon the user): According to directives 2009/104/EC and 1999/92/EC, these zones might be qualified by the user as ATEX Zone based on the user's own risk analysis for which the user remains solely responsible. According to the definition of Annex I of directive 1999/92/EC, this zone might be classified Zone 2 because it might be a place in which an explosive atmosphere consisting of a mixture of air

with flammable substances in the form of gas is not likely to occur in normal operation but, if it does occur, will persist for a short period only.

In case an additional equipment is necessary (motorized valve, pump, etc...), it must be:

- installed out of defined potentially flammable zone;
- qualified as a non-ignition source for the fluid used.

Positioning of potentially flammable zones around the unit:

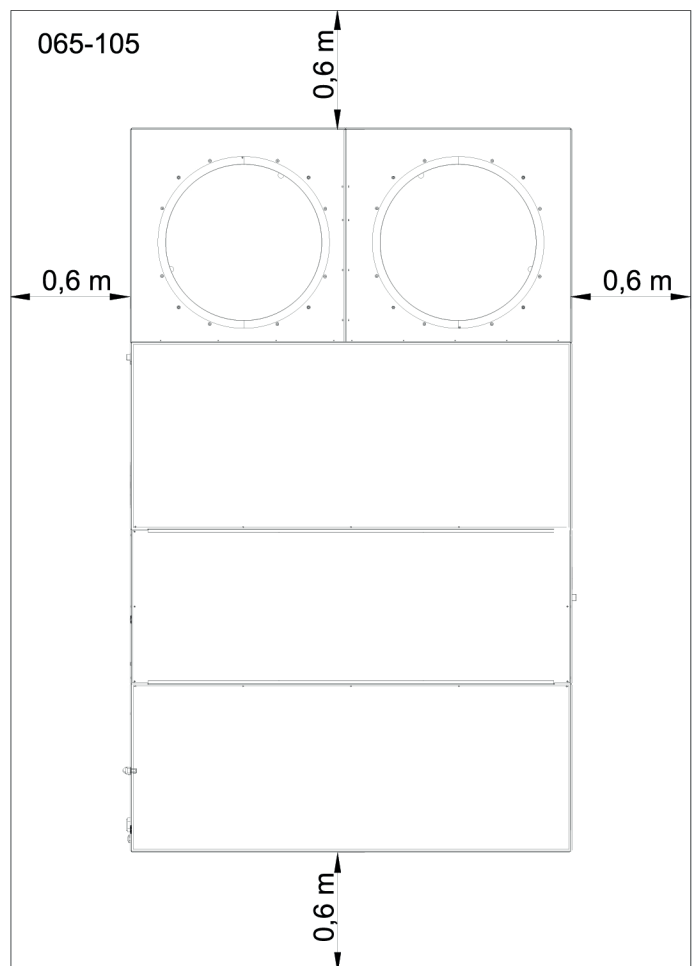
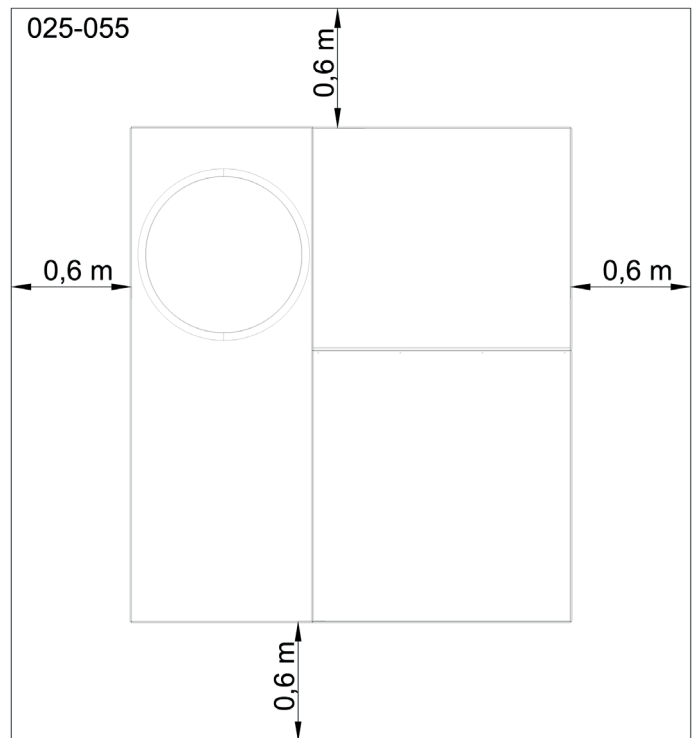

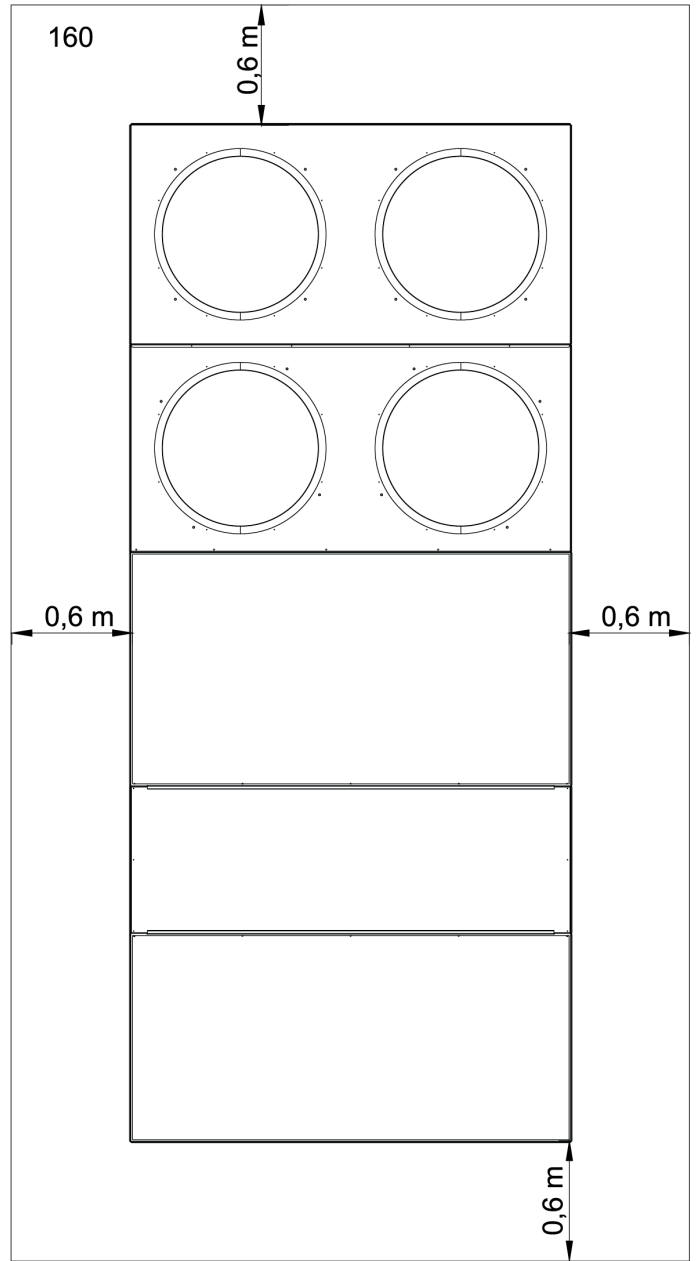
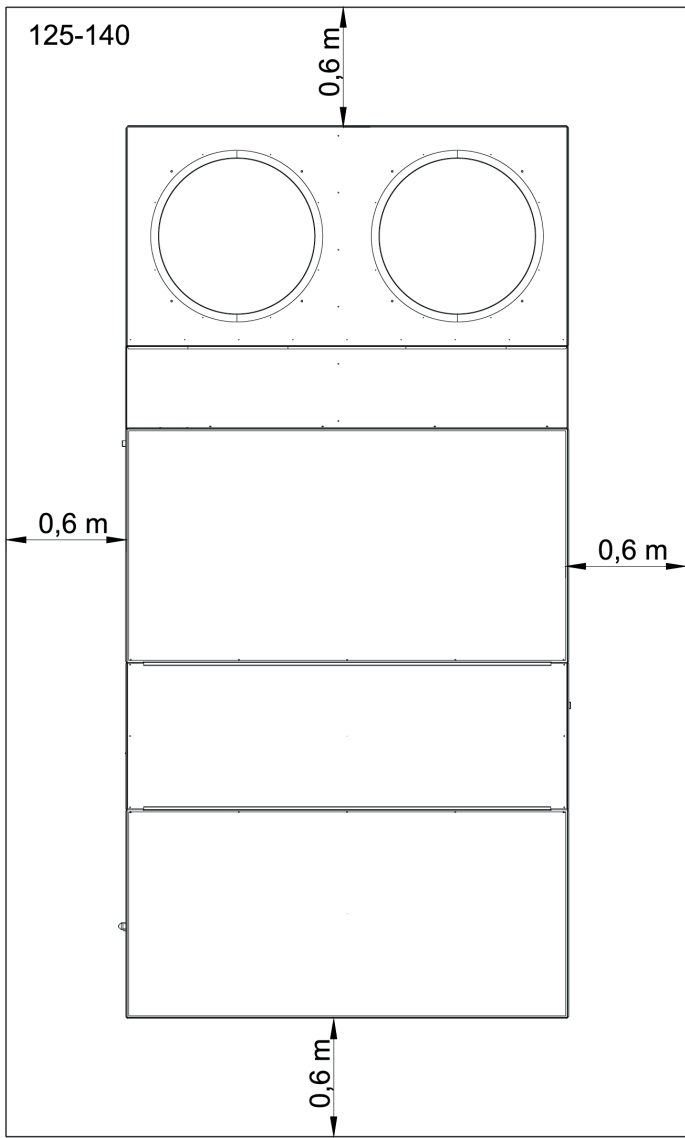

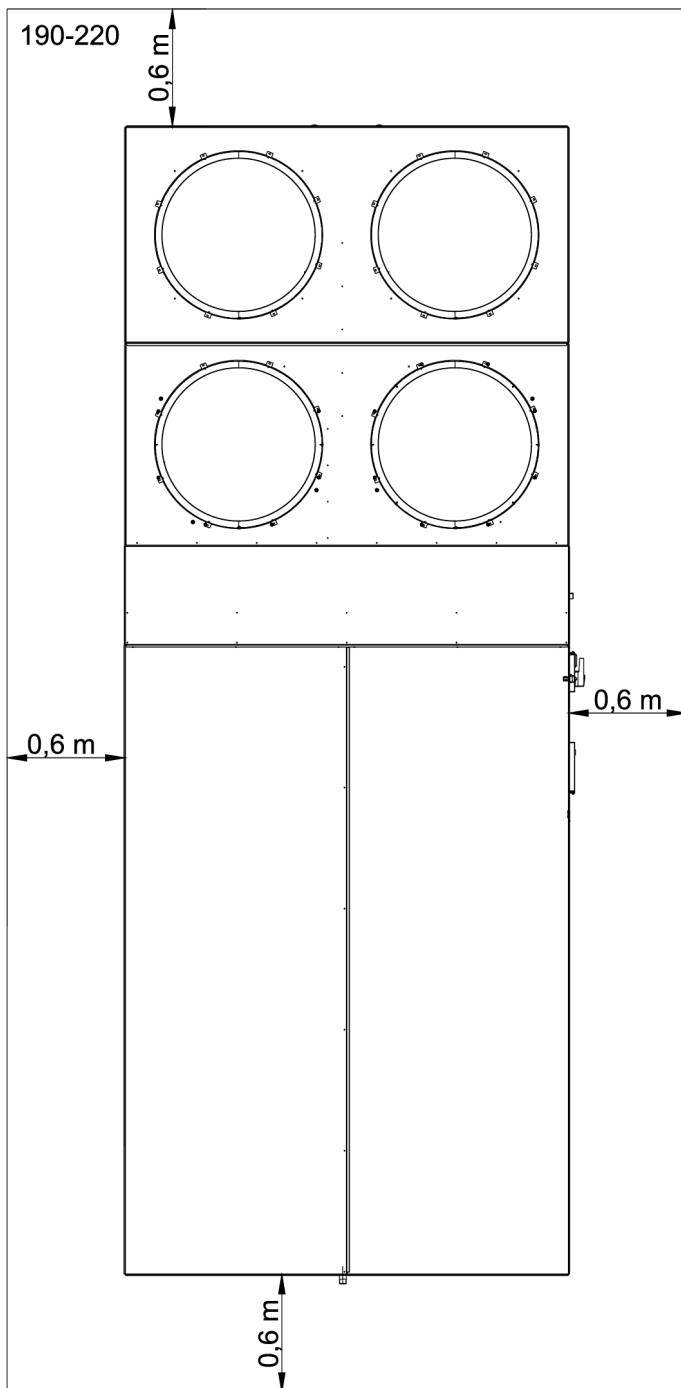

48/50UP-	025	035	045	055	065	075	090
Refrigerant charge per circuit (kg)	7.00	9.50	11.00	16.50	11.00	13.50	13.50
Minimum area (m <sup>2</sup> )	33.7	62.1	83.2	127.1	83.2	104.0	104.0

48/50UP-	105	125	140	160	190	220
Refrigerant charge per circuit (kg)	15.50	19.00	19.00	21.00	26.50	28.00
Minimum area (m <sup>2</sup> )	119.4	146.4	146.4	161.8	204.2	215.7

48/50UCV	025	035	045	055	065	075	090
Refrigerant charge per circuit (kg)	7.00	9.50	11.00	13.50	11.00	14.00	14.00
Minimum area (m <sup>2</sup> )	33.7	62.1	83.2	104.0	83.2	107.9	107.9

48/50UCV	105	125	140	160	190	220
Refrigerant charge per circuit (kg)	15.50	19.00	21.00	21.00	26.50	28.00
Minimum area (m <sup>2</sup> )	119.4	146.4	161.8	161.8	204.2	215.7

48/50UPV	025	035	045	055	065	075	090
Refrigerant charge per circuit (kg)	7.00	9.50	11.00	13.50	11.00	13.50	13.50
Minimum area (m <sup>2</sup> )	33.7	62.1	83.2	104.0	83.2	104.0	104.0

48/50UPV	105	125	140	160	190	220
Refrigerant charge per circuit (kg)	15.50	19.00	21.00	21.00	26.50	28.00
Minimum area (m <sup>2</sup> )	119.4	146.4	161.8	161.8	204.2	215.7

Important: It is the customer's responsibility to carry out the risk analysis of the installation and, as a result of that analysis, to take the necessary measures according to standard EN-378-1.

Consult the following recommendations about A2L rooftop installation. These units are equipped as standard with a leak detector that from a certain concentration of gas (adjustable) activates a PROTECTION MODE until the mitigation of the leak

#### A2L rooftop installation cases

The rooftop units are designed to be usually installed outdoors, in a free field-type, well ventilated area but also be placed inside a technical room.

The rooftop is a packaged unit with two parts: the external part in contact with the outdoor air flow and

#### Minimum area for indoor air distribution (R454B)

The unit with refrigerant R-454B (A2L fluid) needs a minimum surface in the room where the air supplied by its indoor circuit will be distributed, according to EN-378-1:

48/50UC-	025	035	045	055	065	075	090
Refrigerant charge per circuit (kg)	7.00	9.50	11.00	16.50	11.00	14.00	14.00
Minimum area (m <sup>2</sup> )	33.7	62.1	83.2	127.1	83.2	107.9	107.9

48/50UC-	105	125	140	160	190	220
Refrigerant charge per circuit (kg)	15.50	19.00	19.00	21.00	26.50	28.00
Minimum area (m <sup>2</sup> )	119.4	146.4	146.4	161.8	204.2	215.7

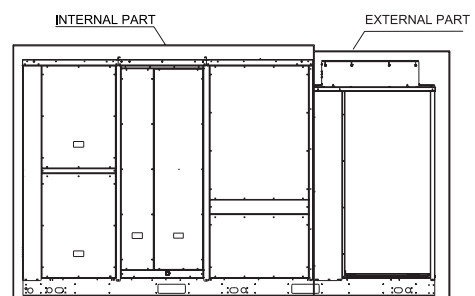

The internal part in contact with the air of the occupied space and the outdoor air through the extraction and fresh air damper connection.

Difference between external and internal part of the rooftop must be done to identify a leakage event in the installation. This clarification is done to identify where the leak event is placed in every situation because of it is managed on different ways. Different scenarios may happen:

- If the leak event is placed in the external part of the rooftop, the leak is produced in the zone where the unit is placed, usually outdoors. If the machine is placed inside a technical room, the leak could affect the room.
- If the leak event is placed in the internal part of the rooftop, the leak may affect the inside of the building through the ducts system. If the unit is placed inside a technical room, the leak could affect the room through the extraction and fresh air damper connection.

In units with refrigerant R454B, due to the nature of this refrigerant (A2L fluid), potentially flammable zones have been identified and positioned around the units, as shown in the diagram opposite.

The potentially flammable zones, as defined, must only be entered by suitably trained personnel equipped with the appropriate detection material and tools for working in a flammable zone.

Never apply an open flame or live steam to a refrigerant container. Dangerous overpressure can result.

In case of combustion of refrigerant, do not clean combustion by-products with water, the mixture is highly corrosive.

The leak event can occur in the external part. For the following installation cases, recommendations will be provided for the external section. All measures must be taken to prevent fluid entering inside building, for example the distance with all opening (window, doors, etc.).

In the potentially flammable zones the presence of ignition sources (electrical power source, mobile phone or any other heat source) is prohibited, even temporarily. They also cannot be installed in or near the duct network of the unit.

In these zones, the installation of fresh air vent or extractors of the building is also prohibited.

**FREE FIELD INSTALLATION**

Rooftop is installed without obstacles around, avoiding accumulation of refrigerant fluid in case of leak.

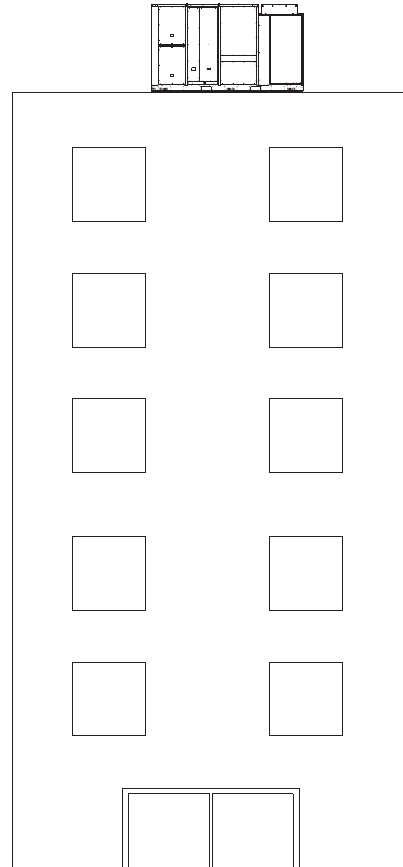

The minimum distance with building or walls is given to allow circulation of technician around the unit during maintenance. You must always refer to the related section of IOM to ensure minimum installation distance is respected for your unit.

Do not install ignition sources inside the potentially flammable area generated by the unit

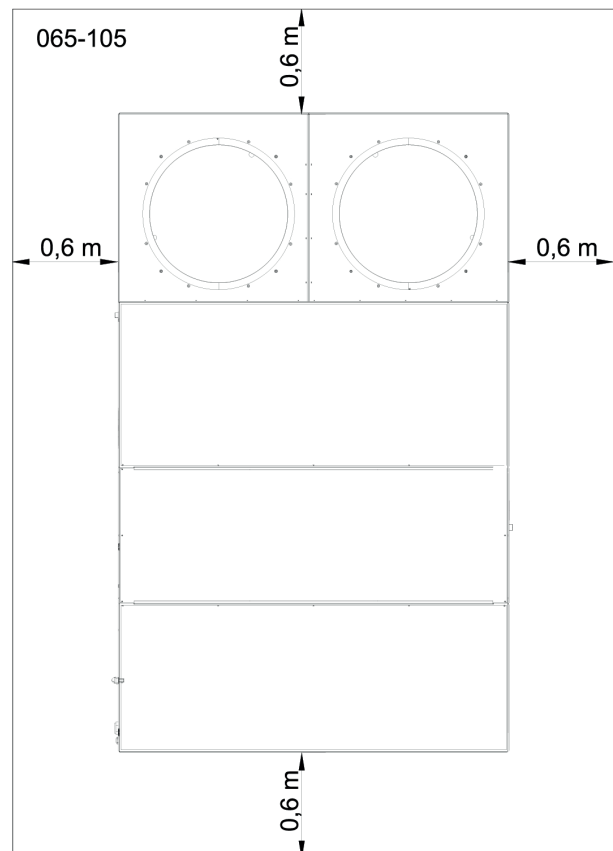

In case additional equipment is necessary (for example, an electrical power source), it must be:

- Installed out of defined flammable area
- Qualified as a non-ignition source for the fluid used

**OUTDOOR CONFINED SPACE INSTALLATION**

**Small Spaces**

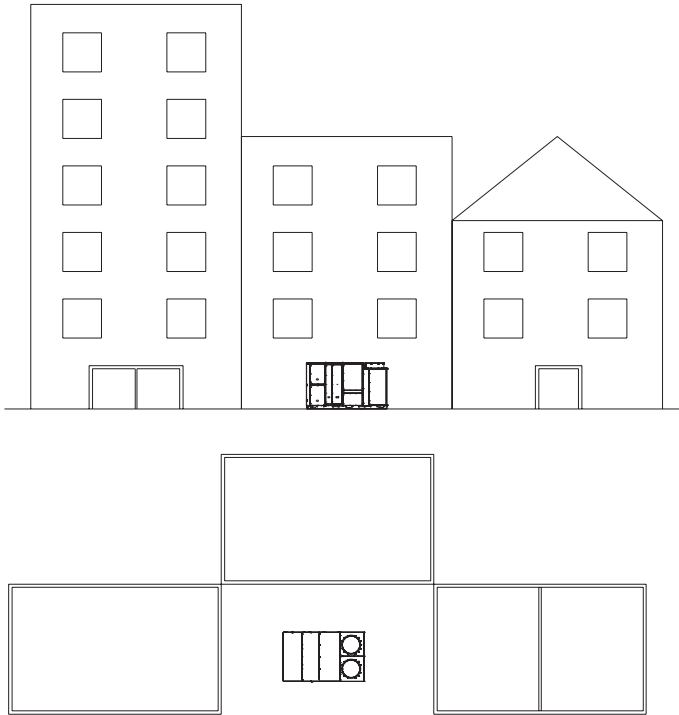

In that case, natural ventilation might be reduced, and refrigerant could accumulate within the restricted space in case of leakage event. Customers must ensure no accumulation of refrigerant is possible.

Commonly used solutions (non-exhaustive list) are:

- Risk analysis demonstrating no accumulation risk
- Additional ventilation system for identified accumulation areas
- + leak detector
- Opening in wall at the position of the accumulation area

Choice of solution is the responsibility of the customer and the individual site specification.

In case additional equipment is necessary (for example, an electrical power source), it must be:

- Installed out of defined flammable area
- Qualified as a non-ignition source for the fluid used

**Installation over a pit**

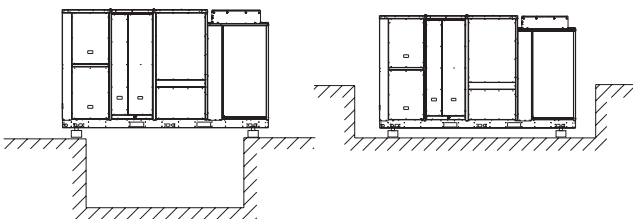

Slightly flammable fluids used have a density higher than air. In case of leak, the main risk is stagnation at the lowest point.

If a unit is mounted in or over a pit, customer must ensure evacuation of gas is possible.

Commonly used solutions (non-exhaustive list) are:

- Vent duct
- Ventilation system + leak detector

Choice of solution is the responsibility of the customer and the individual site specification.

In case an additional equipment is necessary (for example, an electrical power source), it must be:

- Installed out of defined potentially flammable area
- Qualified as a non-ignition source for the fluid used

**Acoustic package**

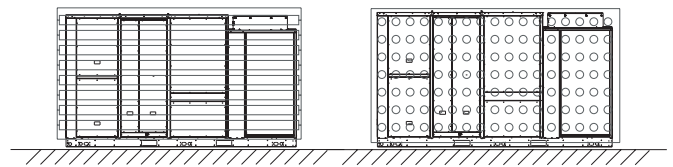

Some noise reduction systems have an impact on air circulation (packages, louvered panels, etc.).

The customer must ensure that the acoustic system in place does not allow refrigerant fluid accumulation, especially low down.

An alternative solution is to equip the system with a leak detector that ensures cutting the power and stopping unit operations.

Choice of solution is the responsibility of the customer and the individual site specification.

In case an additional equipment is necessary (electrical power source, etc.), it must be:

- Installed out of defined flammable area
- Qualified as a non-ignition source for the fluid used

**Under shelter or covered area**

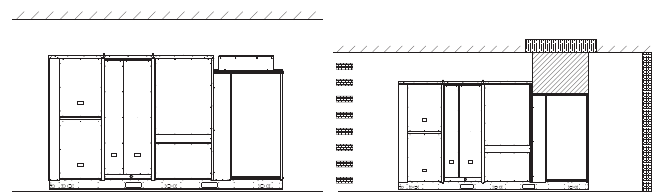

Under shelter is an area or location open to atmosphere or where if enclosed it is longest wall has an opening size of > 75%

to outside. Under EN 378-3 standard this type of installation can be considered as an outdoor installation.

Customer must still ensure accumulation of refrigerant is not possible.

Commonly used solutions (non-exhaustive list) are:

- Risk analysis demonstrating no accumulation risk
- Permanent ventilation system avoiding gas accumulation
- Additional ventilation system for identified accumulation areas + leak detector
- Opening in wall at the position of the accumulation area

Choice of solution is the responsibility of the customer and the individual site specification.

In case an additional equipment is necessary (electrical power source, etc.), it must be:

- Installed out of defined flammable area
- Qualified as a non-ignition source for the fluid used

### INDOOR INSTALLATION

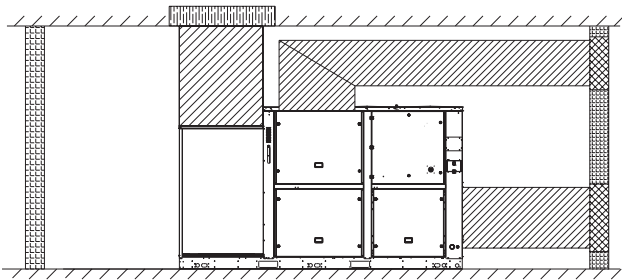

Rooftop units are designed for outdoor installation with zero ESP for outdoor fans. In case units are installed in an indoor space, installation requirements provided by EN378-3 standard must be applied.

All necessary protection required must be employed (leak detection and adequate ventilation).

Choice of solution is the responsibility of the customer and the individual site specification.

In case additional equipment is necessary (motorized valve, pump, et), it must be:

- Installed out of defined flammable area
- Or qualified as a non-ignition source for the fluid used

### VARIANTS&CORRESPONDING INSTALLATION

The site examples shown in this document are for illustration purposes only and will differ in practice.

Below are further examples with corresponding installation comments.

#### Room with inlet/outlet only from the ceiling

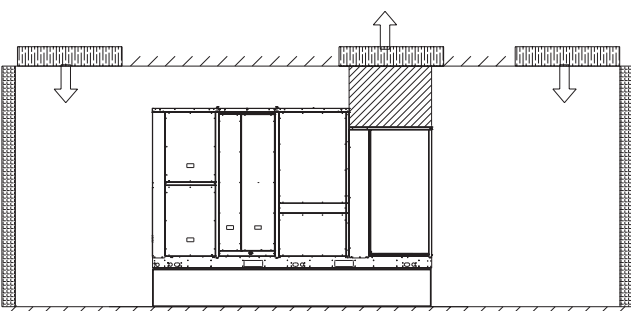

It should be considered as indoor installation.

### UNIT MOUNTED ON PLATFORM

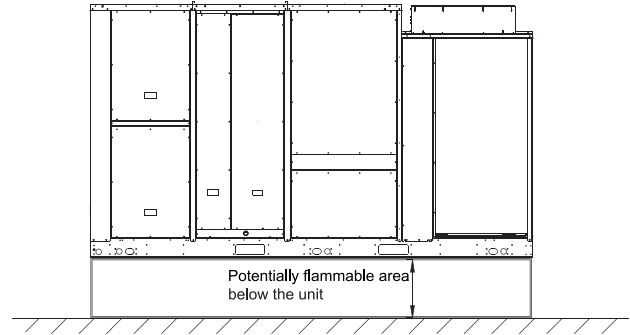

Flammable area below the unit depends on ventilation:

- Good ventilation: can be considered as free field installation → flammable area dimension is the same than on unit side
- Lack of ventilation: should be considered as installation over/in a pit → flammable area extends down to the floor

### INTERNAL PART OF THE ROOFTOP

The leak event can take place in the internal section. In this case the installation requirements provided by EN 378-3 standard

must be applied. All necessary protection required must be employed (leak detection and adequate ventilation).

#### Minimum construction area

According to the EN 378-1 standard a minimum room surface is required depending on the refrigerant charge by circuit.

- According to C.2. of EN 378-1 and considering the charge limit will not be more than  $m^2 \times 1,5$ , the calculation is as follows:

$$A_{min} = m^2 / (2,5 \times LFL^{5/4} \times h_0)^2$$

m is the refrigerant charge amount in the system in kg

LFL is the Lower Flammable Limit in kg/m<sup>3</sup>. This value must be taken from the Supplier Datasheet.

h<sub>0</sub> is the height factor of the appliance:

- 0,6 for floor location
- 1,8 for wall mounted
- 1,0 for window mounted
- 2,2 for ceiling mounted

- According to C.3. OF EN 378-1 and considering the charge limit is not more than  $m^3 \times 1,5$ , the calculation as follows:

$$A_{min} = m / (QLMV * h)$$

m is the refrigerant charge amount in the system in kg

QLMV is the quantity limit with minimum ventilation

h is the heigh of supply air flow to the room in m; max 2,2 m according the EN-378 standard

#### Periodical sealing control

This maintenance period depends on the refrigerant charge of CO<sub>2</sub> equivalent by circuit and the existence or not of

leakage detection system. For more information, see related section of IOM and your local regulations.

#### Position recommendation

It is recommended to position leak detector(s) at the lowest point of the identified accumulation area.

#### Leak detector for rooftop indoor

The internal part of the rooftop with R454B includes a leak detector with infrared and self-calibration

### 2.3 - Checks Before System Start-up

Before the start-up of the refrigeration system, the complete installation, including the refrigeration system must be verified

against installation drawings, dimensional drawings, system piping and instrumentation diagrams and the wiring diagrams.

Follow national regulations for these checks. If the national regulation does not specify any details, refer to standard EN 378-2 as follows: External visual installation checks:

- Ensure that the machine is charged with refrigerant. Verify on the unit nameplate that the 'fluid being transported' is R410A or R454B and is not nitrogen.
- Compare the complete installation with the refrigeration system and power circuit diagrams.
- Check that all components comply with the design specifications
- Check that all protection documents and equipment provided by the manufacturer (dimensional drawings, P&ID, declarations etc.) to comply with the regulations are present.
- Verify that the environmental safety and protection and devices and arrangements provided by the manufacturer to comply with the regulations are in place.
- Verify that all documents for pressure containers, certificates, name plates, files, instruction manuals provided by the manufacturer to comply with the regulations are present.
- Verify the free passage of access and safety routes.
- Verify the instructions and directives to prevent the deliberate removal of refrigerant gases.
- Verify the installation of connections.
- Verify the supports and fixing elements (materials, routing and connection).
- Verify the quality of welds and other joints.
- Check the protection against mechanical damage.
- Check the protection against heat.
- Check the protection of moving parts.
- Verify the accessibility for maintenance or repair and to check the piping.
- Verify the status of the valves.
- Verify the quality of the thermal insulation and of the vapor barriers.
- Check the refrigerant detectors.

## 3 - INSTALLATION

### 3.1 - Unit Base Frame

This unit is for connection to a ducted air system only. It should not be used without ductwork connected to the air outlet or supply side of the unit. It is possible to provide fresh air to the unit air inlet side without the use of ductwork via an optional kit containing a damper system, and protective hood and grilles. Consult the unit supplier or distributor for more information.

Due to the size and weight of the units the base frame must be on a support which fulfils the following requirements:

- The surface area must be sufficient for disturbing the unit weight over the building structure.
- Sufficient drain holes should be provided to avoid the accumulation of rain water.
- The unit should be firmly fixed to the floor
- The structure should be capable of supporting the unit weight during installation and operation.
- The standard unit leaves the factory with the air supply and return in the lower section (see Fig. 1) and the corresponding holes on the roof must be made.

Refer to the certified dimensional drawings for the supply and return openings.

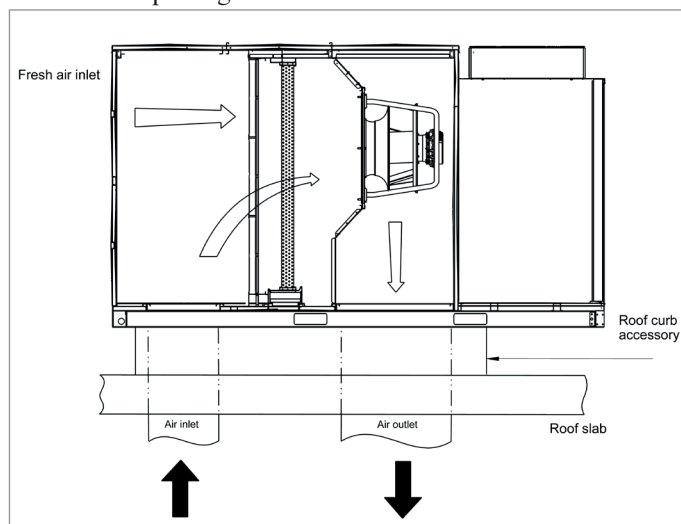

Fig. 1 – Roofcurb accessory – standard vertical supply and return

The unit air supply and return can be from side or top as an option (See Fig. 2a and Fig. 2b ) and also side return and supply via top plenum (See Fig. 2c).

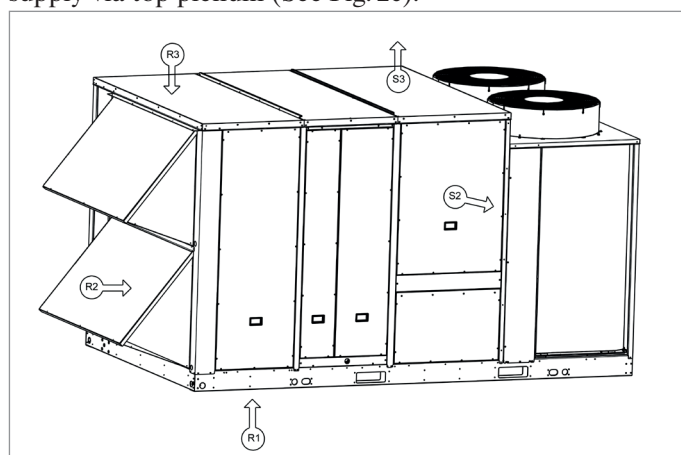

Fig. 2a – Duct configuration standard/optional

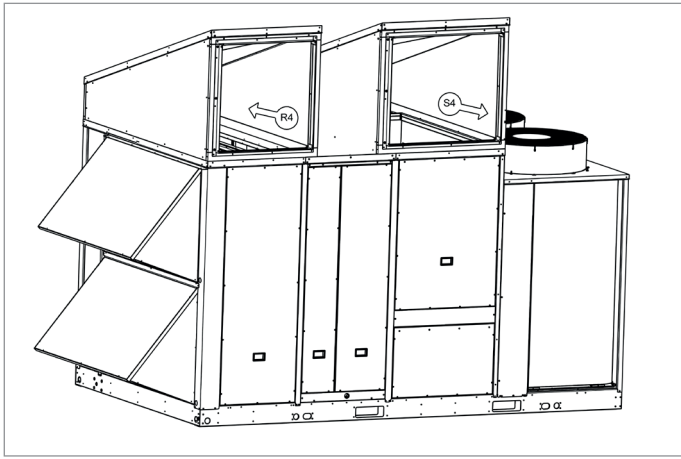

Fig. 2b – Duct configuration via top plenum optional

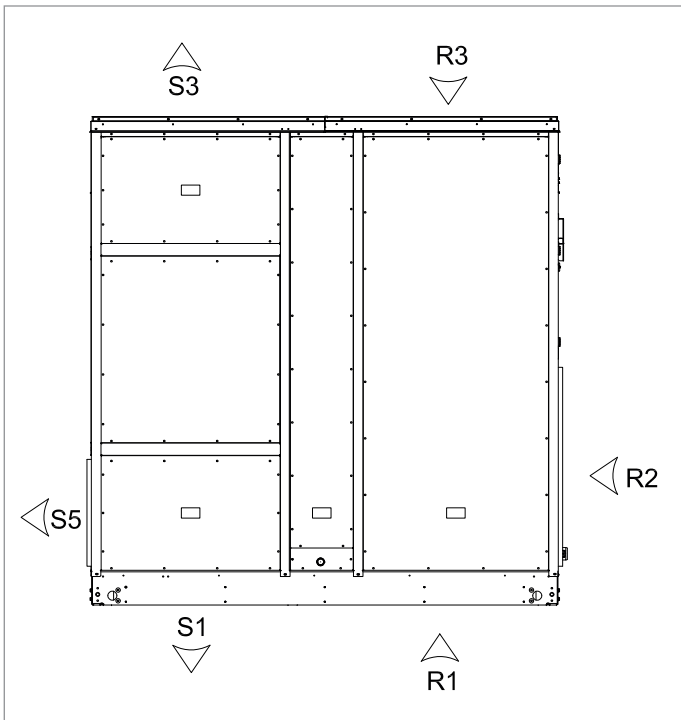

Fig. 2.c - Duct configuration face (rear) optional

### 3.2 - Sensor Connection and Location

The room temperature sensor and supply temperature sensor are located in the control box together with their connectors. Please refer to the wiring diagrams for the required connections and suitable cable diameter. Criteria for selecting sensor locations will vary with system and building specifics

Recommended sensor locations are shown in Fig. 3.

**NOTE:** The return duct sensor or the room temperature sensor can be used.

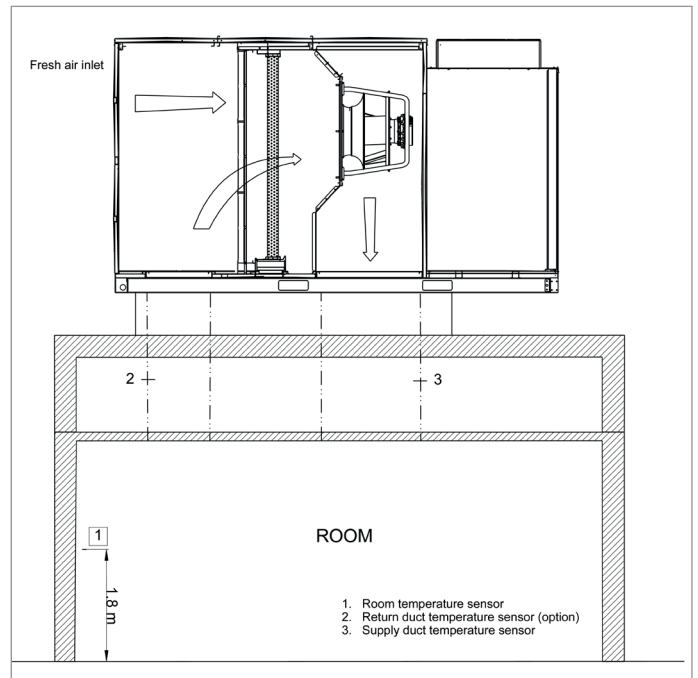

Fig. 3 – Recommended sensor location

### 3.3 - Ductwork

It is necessary to use adequate sealants and joints to ensure correct fitting and water-tightness between the ducts and the support so that air and moisture do not enter the building.

**WARNING:** Do not drill any holes in the indoor coil area as this might damage the condensate drain pan.

**IMPORTANT:** The unit should be correctly levelled to avoid drainage problems.

Determine the ductwork dimensions according to the air flow to be carried, and the available static pressure. The different air flows and static pressures that each unit can supply, are shown in the fan performance tables

It is recommended to observe the following considerations:

- Whatever type of ductwork is used, it should not be made of materials which are flammable or which give off toxic gases in the event of a fire. The internal surfaces should be smooth, and not contaminate the air which passes through. It is recommended to use sheet metal ducts which are adequately insulated to avoid condensation and thermal leakage.
- At the points where the ducts join the unit, it is recommended to use flexible connections which absorb vibrations, prevent noise inside the ductwork and allow access to the unit.
- Bends near the unit outlet should be avoided as much as possible. If unavoidable, they should be as slight as possible, and internal deflectors should be used when the duct has large dimensions.



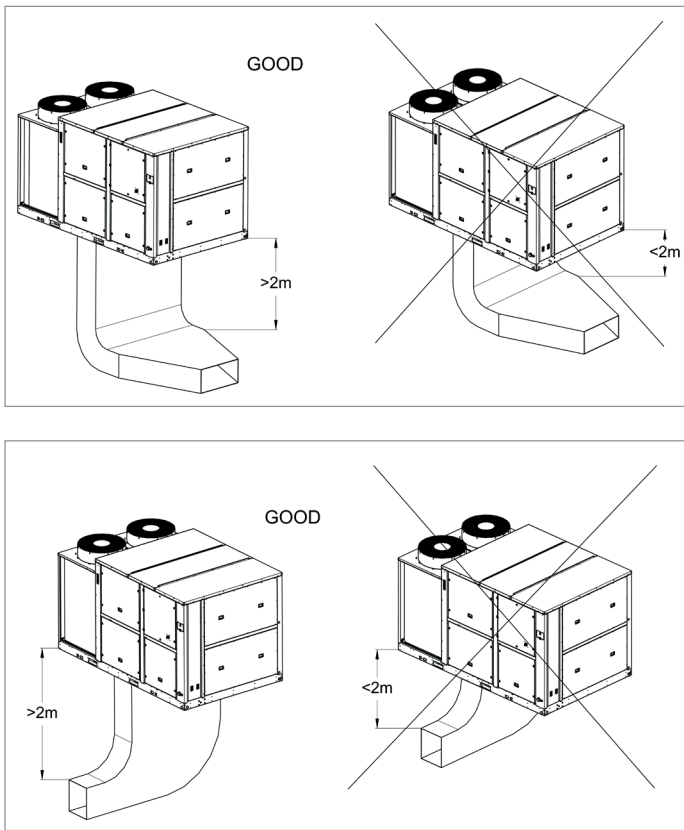

Fig. 4a – Examples for good and bad connections:

Below are some obligations for ductwork:

All ducts should have radial bends. It is highly recommended that no sheets of ductwork have right angle bend.

If duct is directed towards right/left of supply air outlet or there is any change in duct diameter, the ductwork should go downward for at least 2 m before any bend or diameter change (see Fig. 4a). If no change in diameter or direction is involved, it is not obliged.

It is essential to abide by the rules above for all units with gas heating option (48 UC-(V)/UP-(V))

**NOTE:** All duct sizing and design work should be carried out by qualified technicians.

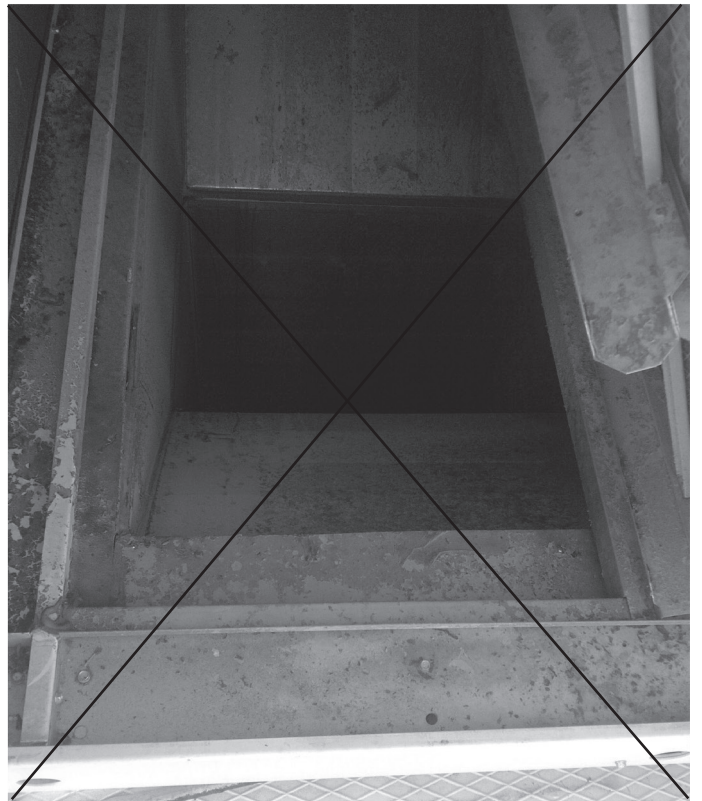

Fig. 4b – Some bad examples on site

### 3.4 - Condensate and Rainwater Drainage

The units incorporate drill holes in the base near the outdoor coils to drain rain water and condensation. The indoor heat exchanger area incorporates a drain pan with an outside drain pipe diameter of 34 mm and a negative drainage siphon as in Fig. 5.

Min. recommended value of X is 180 mm.

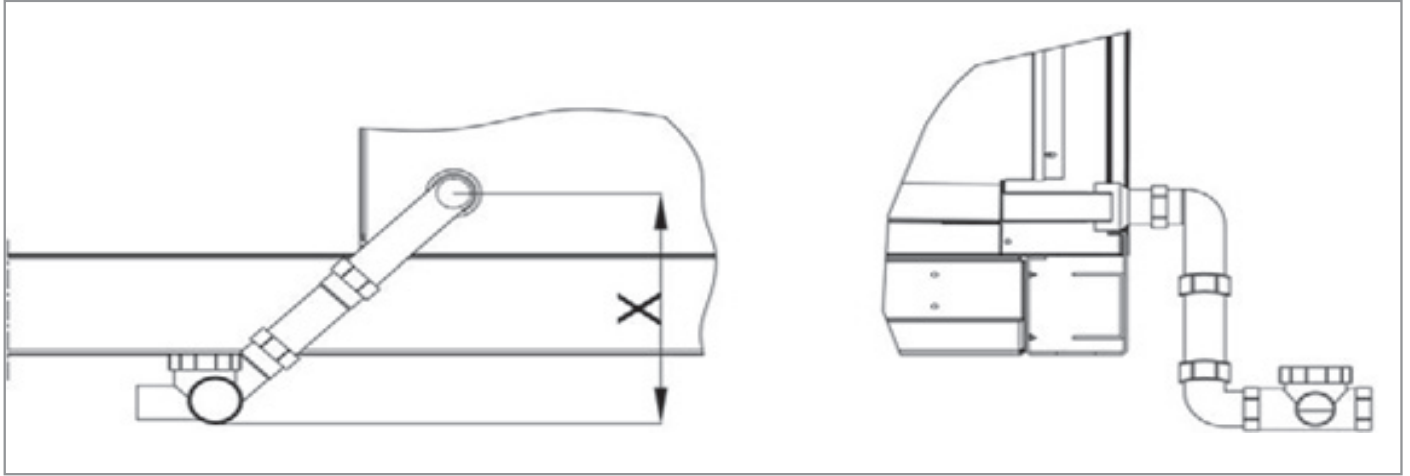
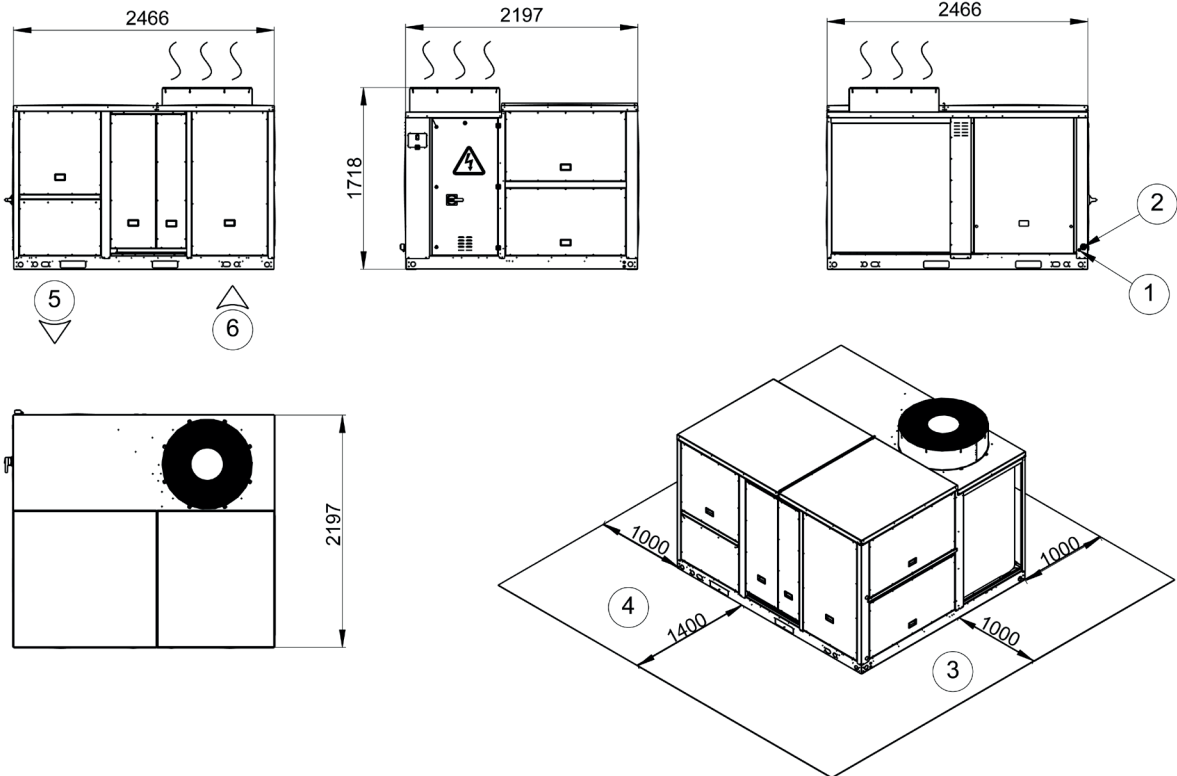

Fig. 5 – Condensate drain pipe details

#### 4- DIMENSIONS, CLEARANCES, mm

50 UC-(V)/UP-(V) 025,035



48 UC-(V)/UP-(V) 025,035

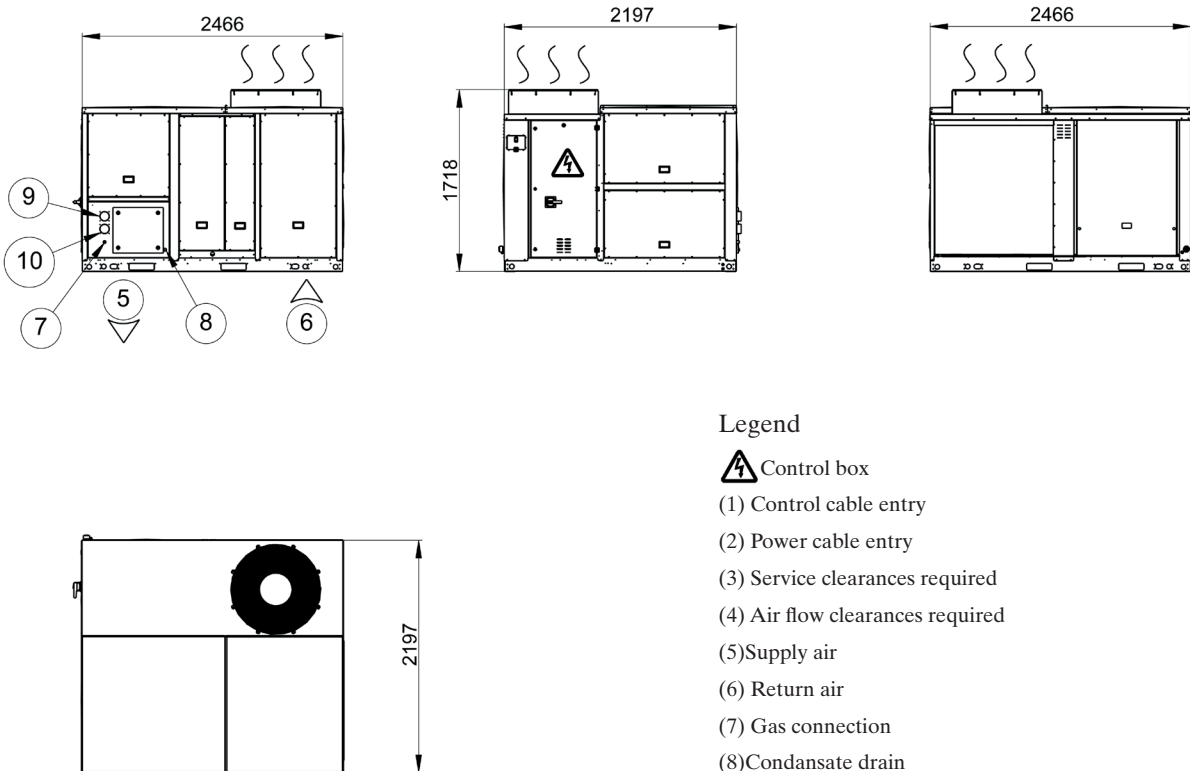

#### Legend

-  Control box
- (1) Control cable entry
- (2) Power cable entry
- (3) Service clearances required
- (4) Air flow clearances required
- (5) Supply air
- (6) Return air
- (7) Gas connection
- (8) Condensate drain
- (9) Fumes exhaust Ø80
- (10) Air intake Ø80
- §§§. Air outlet, do not obstruct

When designing an installation, always use up-to-date drawings, available from your local Carrier Office.

Please refer to the certified dimensional drawings for the units with options such as economizer, power exhaust, air return fan, etc.

50 UC-(V)/UP-(V) 045,055

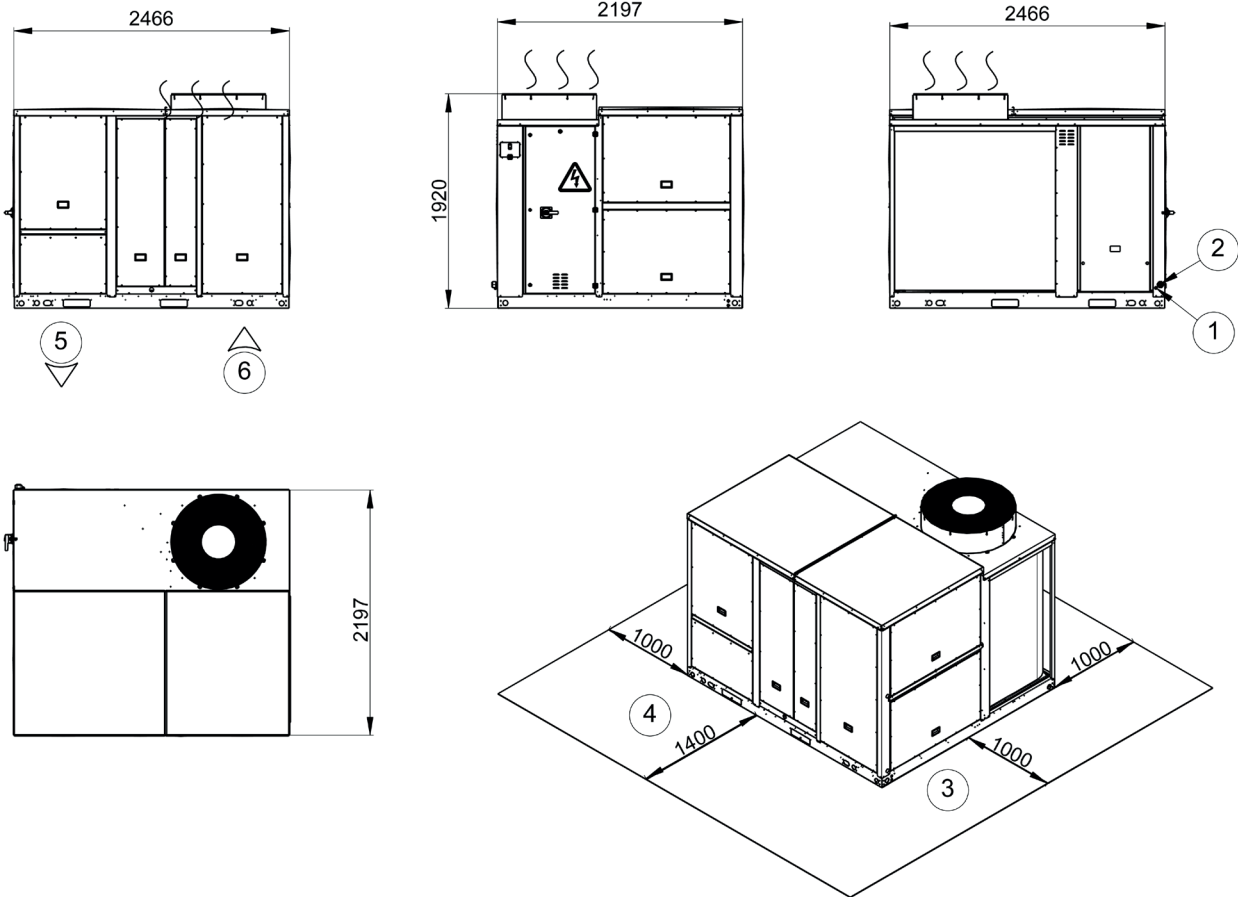

48 UC-(V)/UP-(V) 045,055

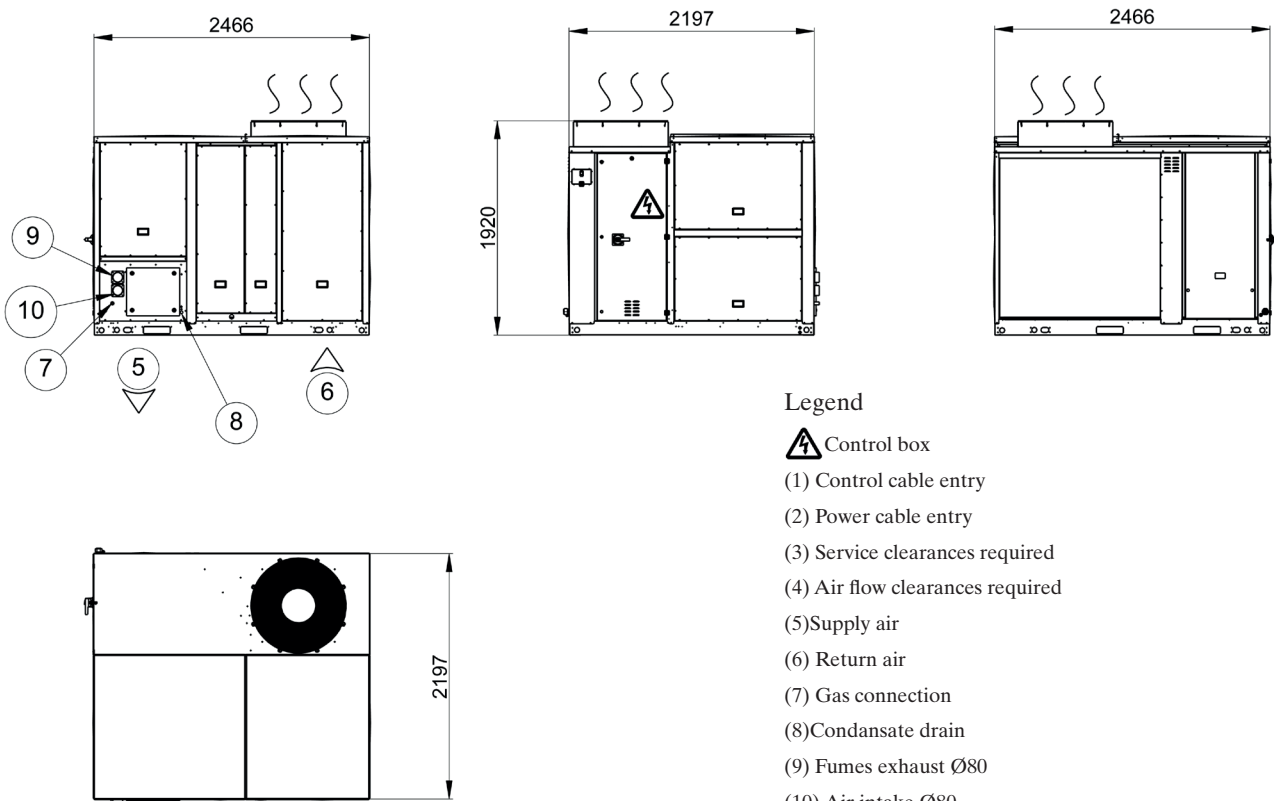

Legend

-  Control box
- (1) Control cable entry
- (2) Power cable entry
- (3) Service clearances required
- (4) Air flow clearances required
- (5) Supply air
- (6) Return air
- (7) Gas connection
- (8) Condensate drain
- (9) Fumes exhaust Ø80
- (10) Air intake Ø80

§§§ Air outlet, do not obstruct

When designing an installation, always use up-to-date drawings, available from your local Carrier Office.

Please refer to the certified dimensional drawings for the units with options such as economizer, power exhaust, air return fan, etc.

50 UC-(V)/UP-(V) 065,075,090,105

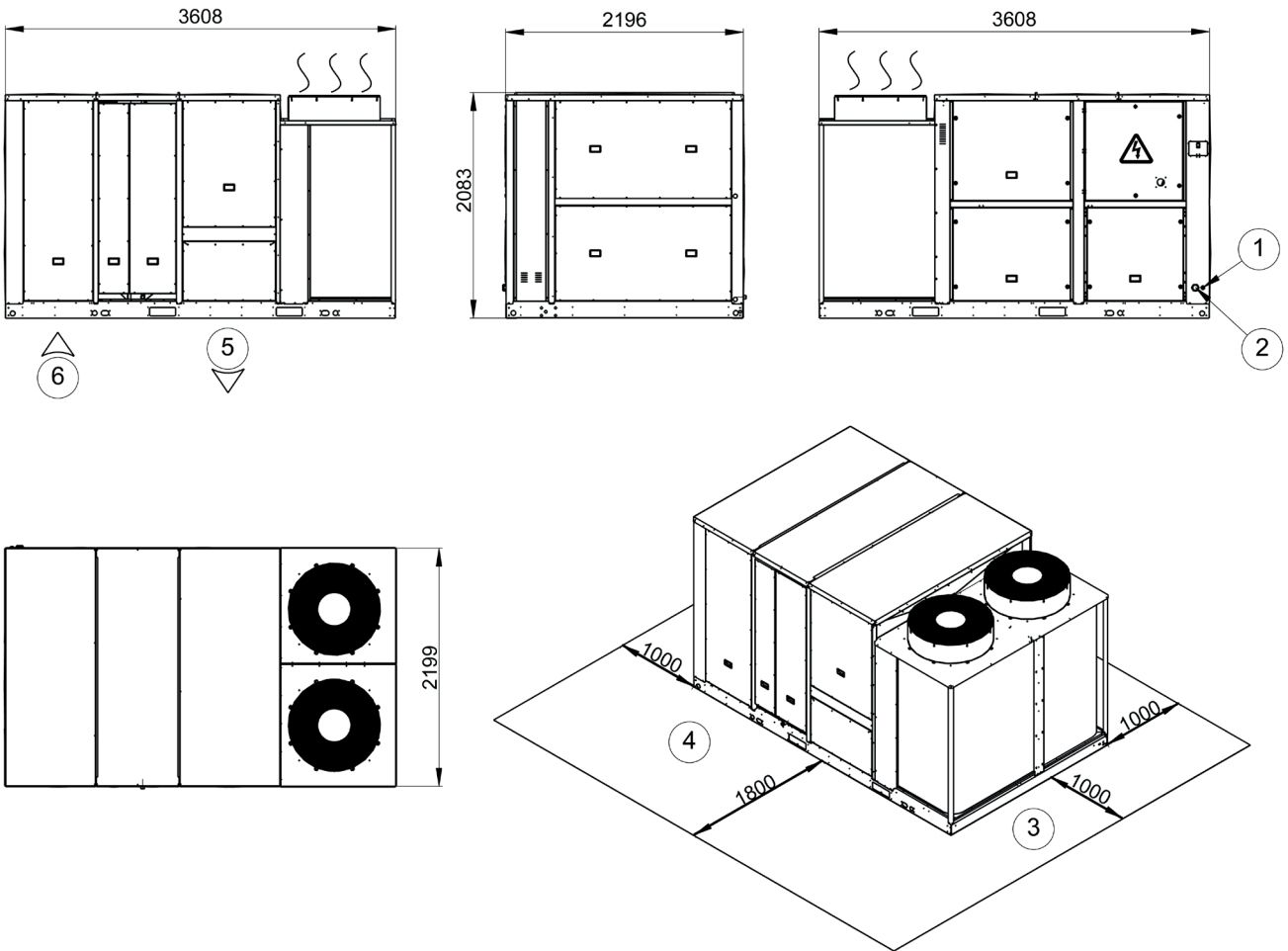

48 UC-(V)/UP-(V) 065,075,090,105

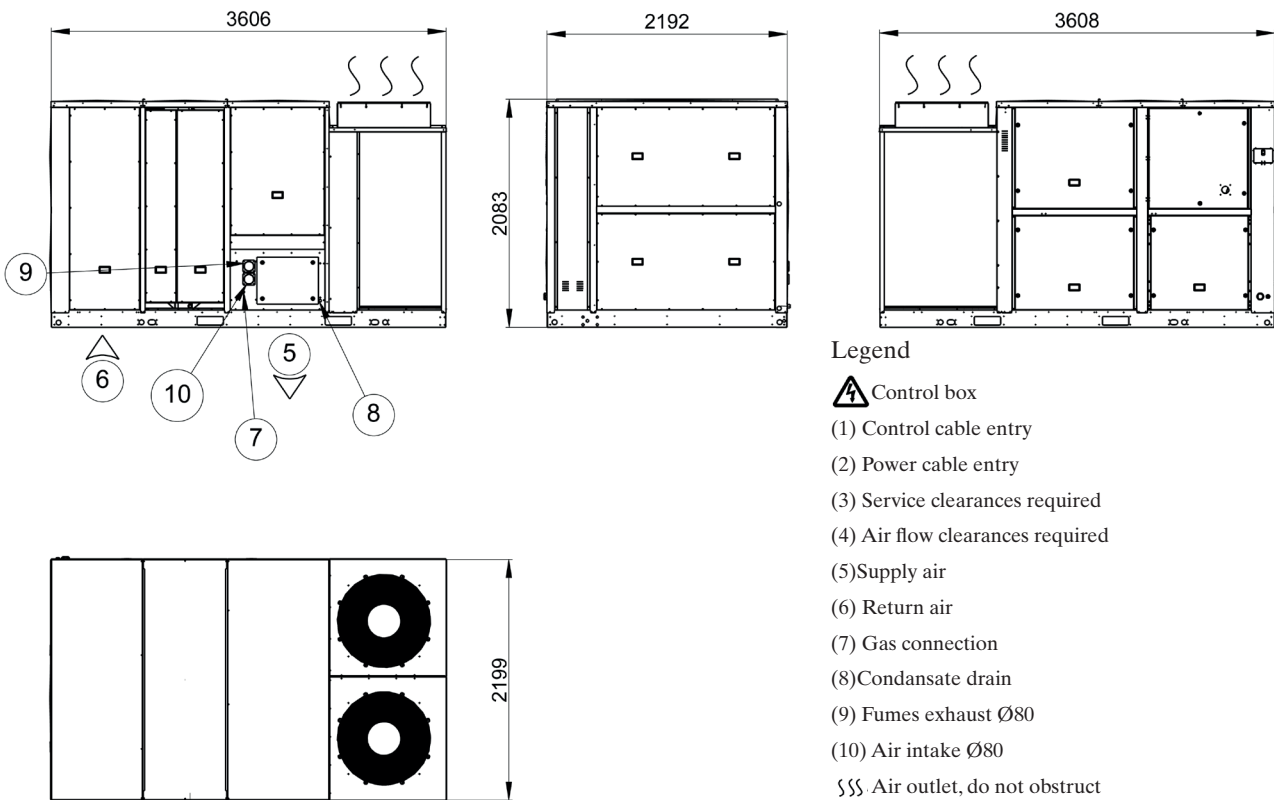

Legend

- Control box
- (1) Control cable entry
- (2) Power cable entry
- (3) Service clearances required
- (4) Air flow clearances required
- (5) Supply air
- (6) Return air
- (7) Gas connection
- (8) Condensate drain
- (9) Fumes exhaust Ø80
- (10) Air intake Ø80
- §§§ Air outlet, do not obstruct

When designing an installation, always use up-to-date drawings, available from your local Carrier Office.

Please refer to the certified dimensional drawings for the units with options such as economizer, power exhaust, air return fan, etc.

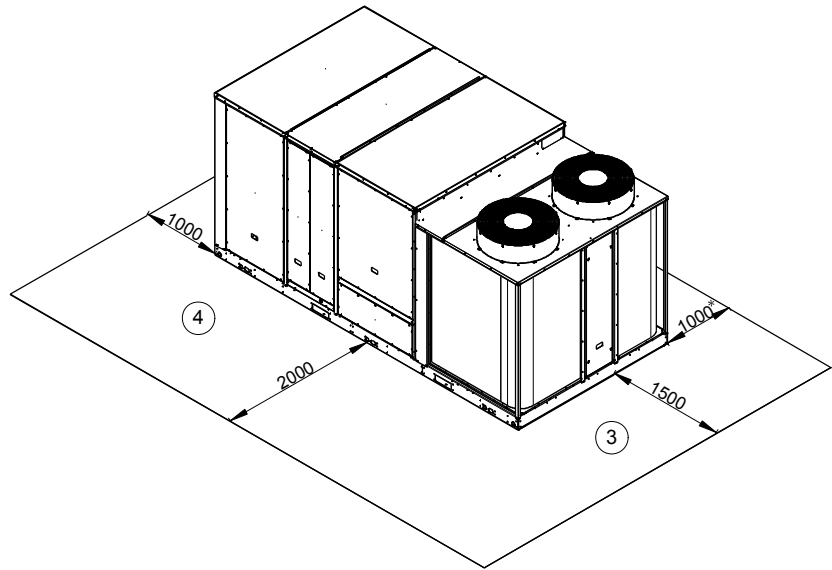
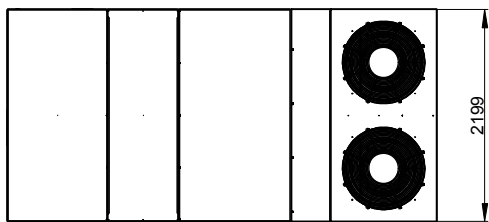
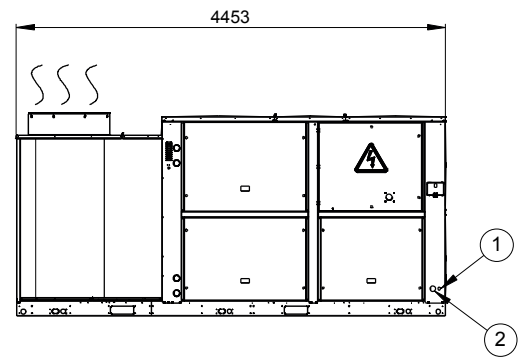
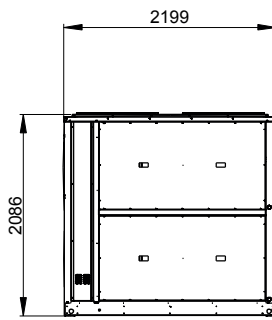
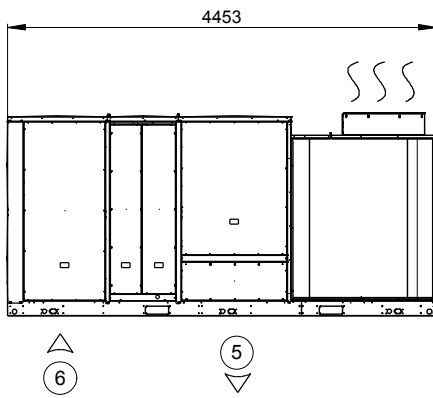

Legend

-  Control box
- (1) Control cable entry
- (2) Power cable entry
- (3) Service clearances required
- (4) Air flow clearances required
- (5) Supply air
- (6) Return air
- (7) Gas connection
- (8) Condensate drain
- (9) Fumes exhaust Ø80
- (10) Air intake Ø80
- SSS Air outlet, do not obstruct

When designing an installation, always use up-to-date drawings, available from your local Carrier Office.

Please refer to the certified dimensional drawings for the units with options such as economizer, power exhaust, air return fan, etc.

\*The spacing will be 1500 mm if UV-C Lamp option is selected

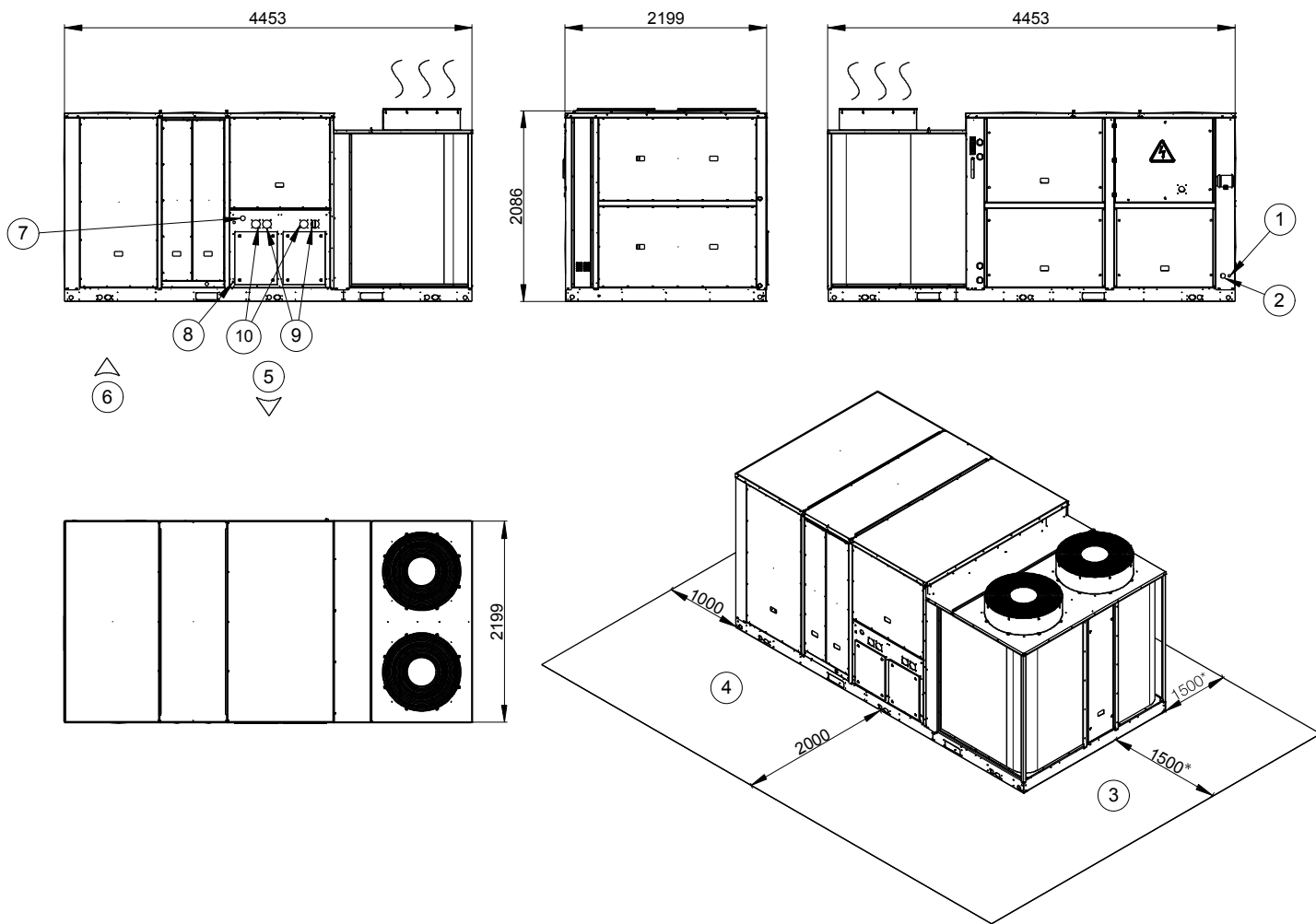

**Legend**

-  Control box
- (1) Control cable entry
- (2) Power cable entry
- (3) Service clearances required
- (4) Air flow clearances required
- (5) Supply air
- (6) Return air
- (7) Gas connection
- (8) Condensate drain
- (9) Fumes exhaust Ø80
- (10) Air intake Ø80
- §§§ Air outlet, do not obstruct

When designing an installation, always use up-to-date drawings, available from your local Carrier Office.

Please refer to the certified dimensional drawings for the units with options such as economizer, power exhaust, air return fan, etc.

\*The spacing will be 1500 mm if UV-C Lamp option is selected

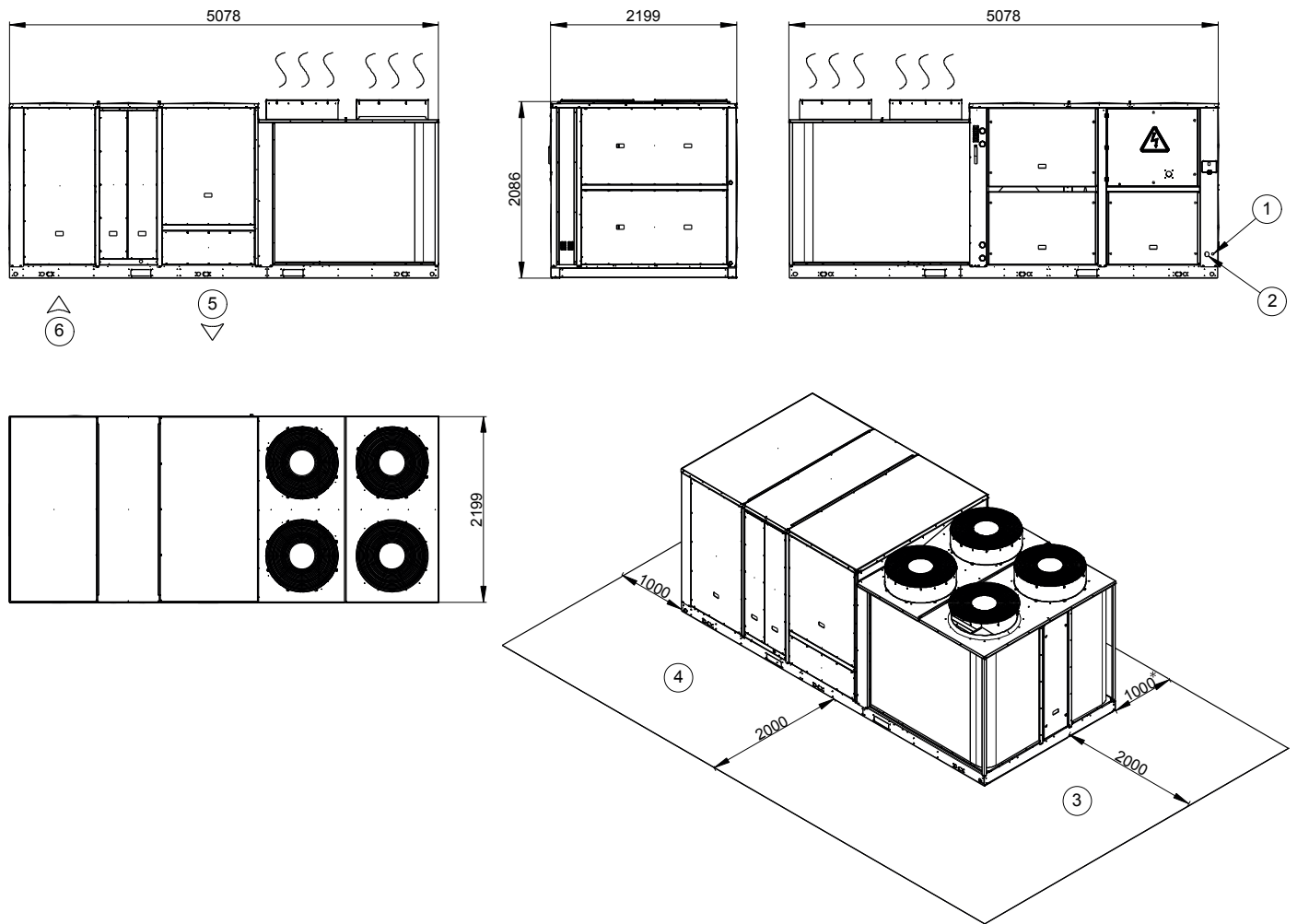

Legend

-  Control box
- (1) Control cable entry
- (2) Power cable entry
- (3) Service clearances required
- (4) Air flow clearances required
- (5) Supply air
- (6) Return air
- (7) Gas connection
- (8) Condensate drain
- (9) Fumes exhaust Ø80
- (10) Air intake Ø80
- §§§ Air outlet, do not obstruct

When designing an installation, always use up-to-date drawings, available from your local Carrier Office.

Please refer to the certified dimensional drawings for the units with options such as economizer, power exhaust, air return fan, etc.

\*The spacing will be 1500 mm if UV-C Lamp option is selected



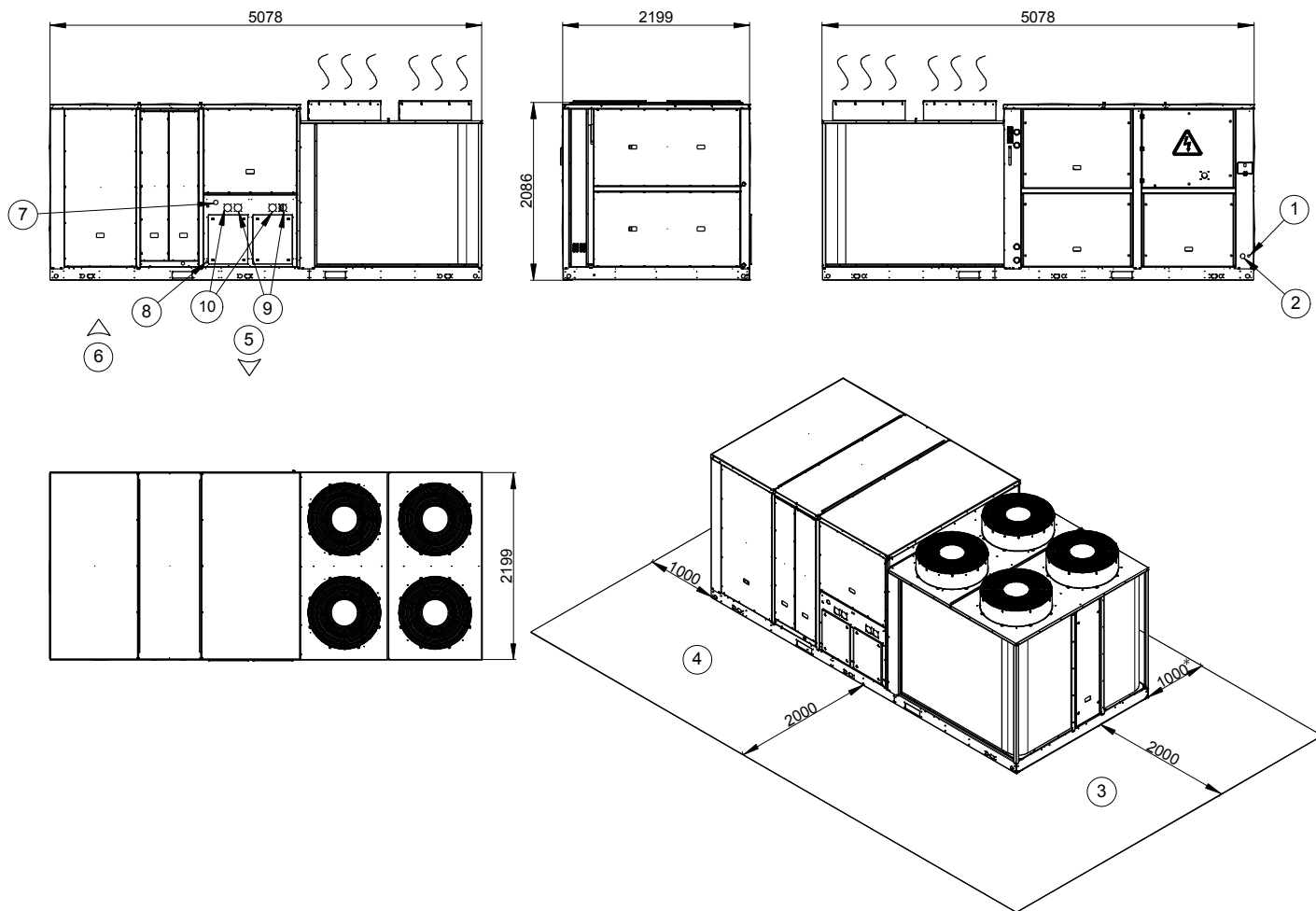

Legend

-  Control box
- (1) Control cable entry
- (2) Power cable entry
- (3) Service clearances required
- (4) Air flow clearances required
- (5) Supply air
- (6) Return air
- (7) Gas connection
- (8) Condensate drain
- (9) Fumes exhaust Ø80
- (10) Air intake Ø80
- SSS Air outlet, do not obstruct

When designing an installation, always use up-to-date drawings, available from your local Carrier Office.

Please refer to the certified dimensional drawings for the units with options such as economizer, power exhaust, air return fan, etc.

\*The spacing will be 1500 mm if UV-C Lamp option is selected

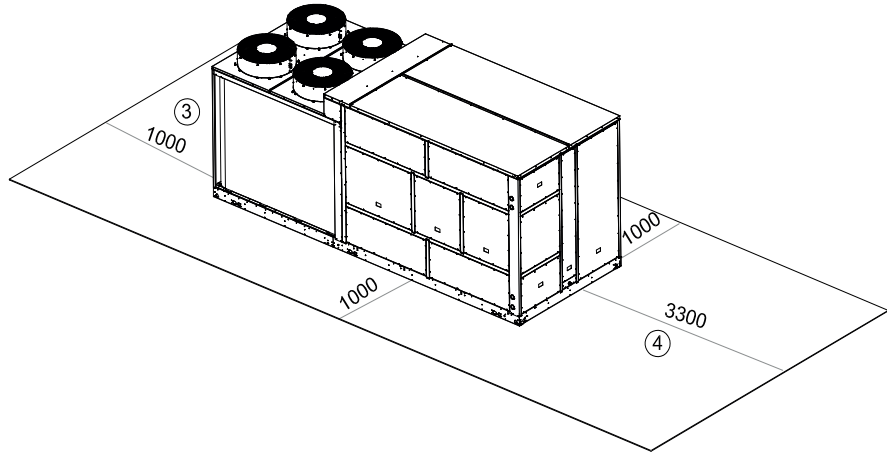
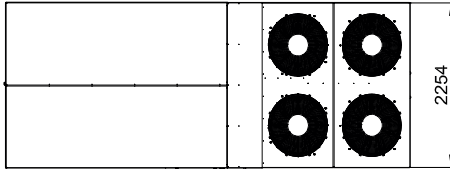
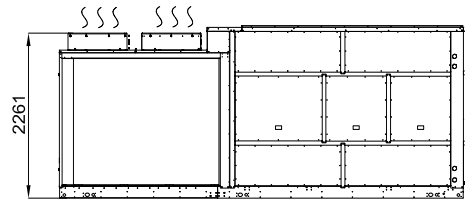
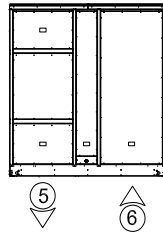
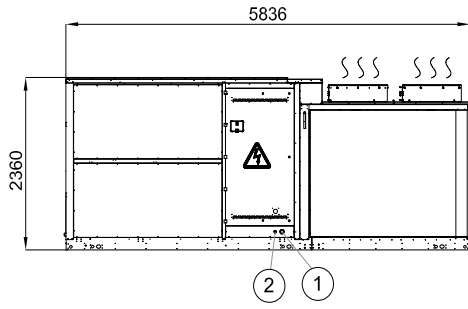

Legend

- Control box
- (1) Control cable entry
- (2) Power cable entry
- (3) Service clearances required
- (4) Air flow clearances required
- (5) Supply air
- (6) Return air
- (7) Gas connection
- (8) Condensate drain
- (9) Fumes exhaust Ø80
- (10) Air intake Ø80
- SSS Air outlet, do not obstruct

When designing an installation, always use up-to-date drawings, available from your local Carrier Office.

Please refer to the certified dimensional drawings for the units with options such as economizer, power exhaust, air return fan, etc.

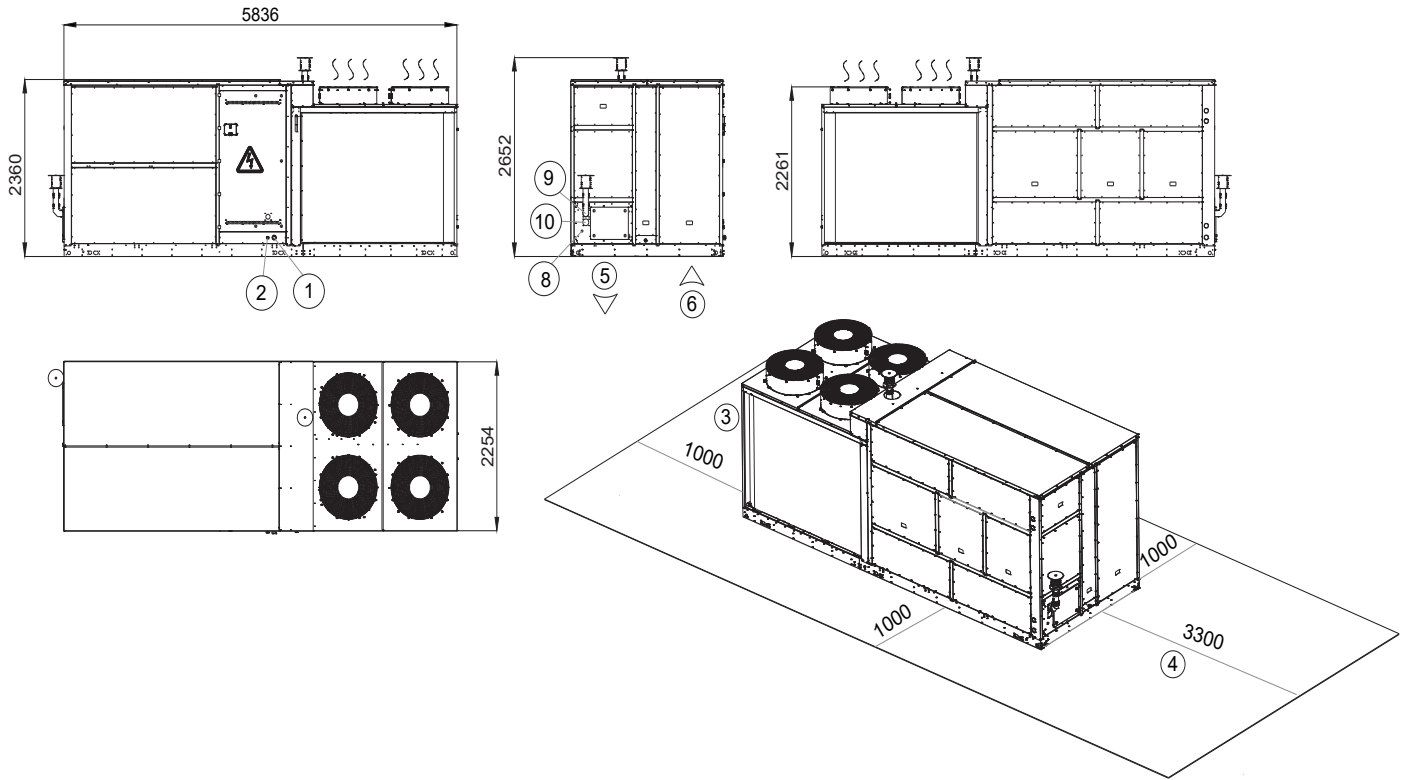

Legend

- Control box
- (1) Control cable entry
- (2) Power cable entry
- (3) Service clearances required
- (4) Air flow clearances required
- (5) Supply air
- (6) Return air
- (7) Gas connection
- (8) Condansate drain
- (9) Fumes exhaust Ø80
- (10) Air intake Ø80
- §§§. Air outlet, do not obstruct

When designing an installation, always use up-to-date drawings, available from your local Carrier Office.

Please refer to the certified dimensional drawings for the units with options such as economizer, power exhaust, air return fan, etc.

### 4.1 - Multiple Rooftop Installation

For 025-035-045-055 sizes;

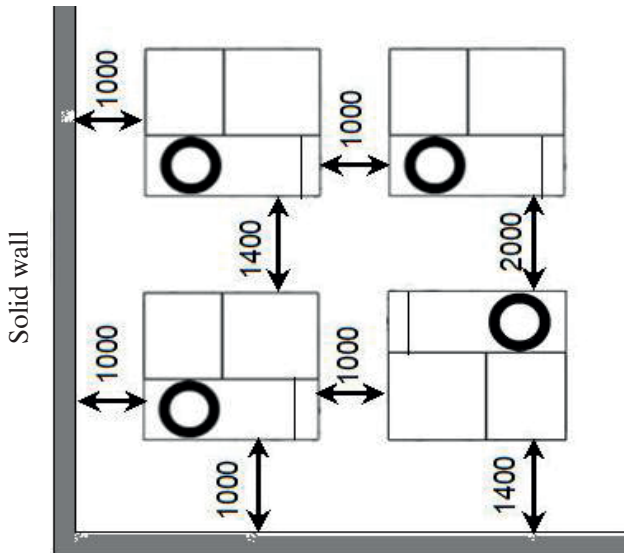

For 065-075-090-105 sizes, S = 1000 mm, for 125-140 sizes, S = 1500 mm

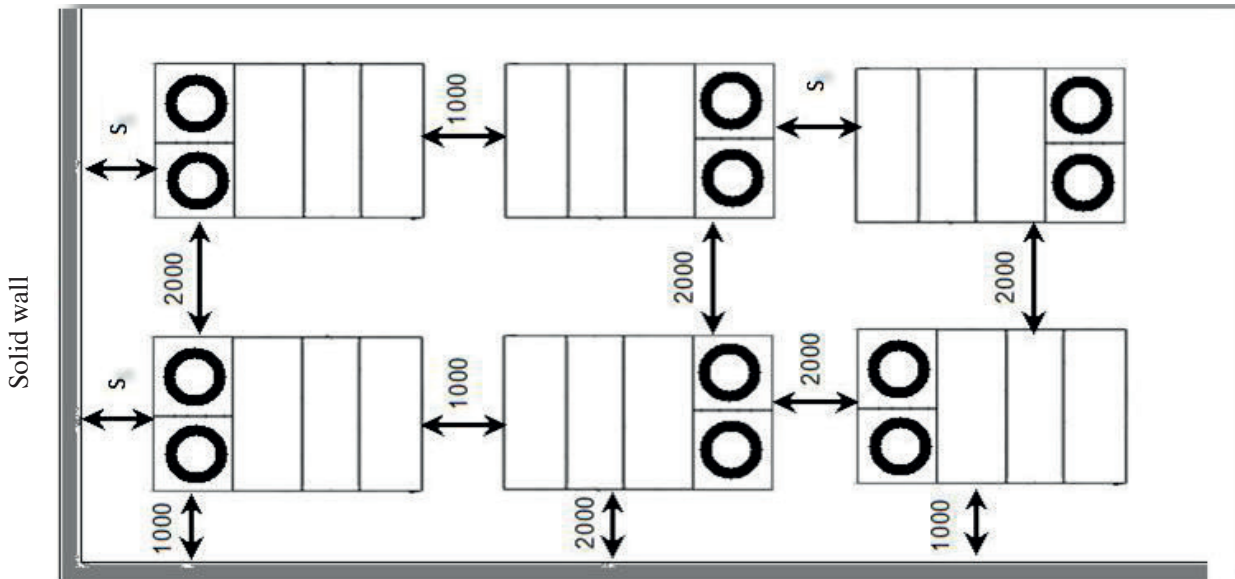

For 160 size, S1 = 2000 mm, S2 = 2000 mm, S3 = 1000 mm; for 190-220 sizes, S1 = 1000 mm, S2 = 3300 mm, S3 = 3300 mm

Solid wall

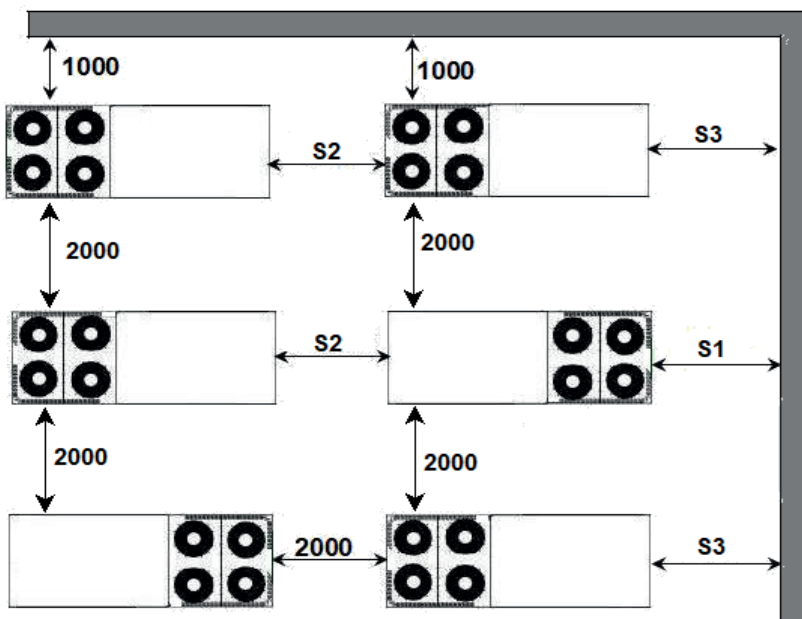

## 5 - PHYSICAL DATA

50 UC/UP(V)	Unit	025	035	045	055	065	075	090	105	125	140	160	190	220
<b>Electric Heaters (Only 50 Series)</b>														
Heating Capacity	kW	18,0	18,0	27,6	27,6	36,0	36,0	45,0	45,0	66,6	88,8	88,8	90,0	90,0
Capacity Steps		9,0+9,0	9,0+9,0	6,9+6,9+13,8	6,9+6,9+13,8	9,0+9,0+18,0	9,0+9,0+18,0	9,0+9,0+18,0	9,0+18,0+18,0	22,2+22,2+22,2	22,2+33,3+33,3	22,2+33,3+33,3	18,0+18,0+27,0+27,0	18,0+18,0+27,0+27,0
Rated Current	A	26	26	40	40	52	52	65	65	96	128	128	130	130
<b>48 UC/UP(V)</b>														
<b>Gas Heaters</b>														
Net Heat Input (Min / Max)	kW	7,60 / 34,85	7,60 / 34,85	8,50 / 42,00	8,50 / 42,00	12,40 / 65,00	12,40 / 65,00	12,40 / 65,00	12,40 / 65,00	21,00 / 100,00	21,00 / 100,00	21,00 / 100,00	16,4 / 164,00	16,4 / 164,00
Heat Output (Min / Max)	kW	8,13 / 33,56	8,13 / 33,56	8,97 / 40,45	8,97 / 40,45	13,40 / 62,93	13,40 / 62,93	13,40 / 62,93	13,40 / 62,93	22,77 / 97,15	22,77 / 97,15	22,77 / 97,15	17,77 / 160,06	17,77 / 160,06
Efficiency	%	107 / 96	107 / 96	106 / 96	106 / 96	108 / 97	108 / 97	108 / 97	108 / 97	108 / 97	108 / 97	108 / 97	108 / 97	108 / 97
Natural Gas Rate (G20)****	m <sup>3</sup> /h	0,80 / 3,69	0,80 / 3,69	0,90 / 4,44	0,90 / 4,44	1,31 / 6,88	1,31 / 6,88	1,31 / 6,88	1,31 / 6,88	2,22 / 10,58	2,22 / 10,58	2,22 / 10,58	3,48 / 17,36	3,48 / 17,36
Capacity Steps		Modulating												
Weight****	kg	48	48	58	58	72	72	72	72	118	118	118	196	196
Power Input ( 230 V-1 Ph-50 Hz )****	W	11 / 74	11 / 74	15 / 65	15 / 65	15 / 97	15 / 97	15 / 97	15 / 97	20 / 130	20 / 130	20 / 130	20 / 123	20 / 123
Gas Connection		UNI/ISO 228/1-G 3/4"												
<b>Refrigeration System</b>														
Compressor Type		Scroll												
Refrigerant		R410A or R454B												
50/48UCV/IUPV No of Circuits / No of Compressors	pcs	1 / 1	1 / 1	1 / 1	1 / 1	2 / 3	2 / 3	2 / 3	2 / 3	2 / 3	2 / 3	2 / 3	2 / 3	2 / 3
50/48UC-IUP- No of Circuits / No of Compressors	pcs	1 / 1	1 / 1	1 / 1	1 / 2	2 / 4	2 / 4	2 / 4	2 / 4	2 / 4	2 / 4	2 / 4	2 / 4	2 / 4
50/48UCV/IUPV Oil: Circuit A - Circuit B	kg	1,3 / -	1,6 / -	3,3 / -	3,6 / -	1,6 / 3,2	3,3 / 3,2	3,3 / 3,2	3,6 / 4,92	3,6 / 6,6	7,7 / 6,6	7,7 / 6,6	7,7 / 7,2	7,7 / 9,7
50/48UC-IUP- Oil: Circuit A - Circuit B	kg	3,3 / -	3,3 / -	3,6 / -	6,6 / -	3,2 / 3,2	3,2 / 3,2	3,2 / 3,2	4,9 / 4,9	6,6 / 6,6	6,6 / 6,6	6,6 / 6,6	7,2 / 7,2	9,7 / 9,7
50/48UPV R410A Charge: Circuit A - Circuit B	kg	8,0 / -	10,5 / -	12,0 / -	15,0 / -	12,0 / 12,0	15,0 / 15,0	15,0 / 15,0	15,0 / 17,0	19,0 / 21,0	23,0 / 21,0	23,0 / 22,0	30,0 / 30,0	34,0 / 34,0
R410A Tons of CO2 equivalent A/B	tCO2e	16,7 / -	21,9 / -	25,1 / -	31,3 / -	25,1 / 25,1	31,3 / 31,3	31,3 / 31,3	31,3 / 35,5	39,7 / 43,8	48,0 / 43,8	48,0 / 45,9	62,6 / 62,6	71,0 / 71,0
50/48UP- R410A Charge: Circuit A - Circuit B	kg	8,0 / -	10,5 / -	12,0 / -	18,0 / -	12,0 / 12,0	15,0 / 15,0	15,0 / 15,0	17,0 / 17,0	21,0 / 21,0	21,0 / 21,0	23,0 / 22,0	32,0 / 32,0	34,0 / 34,0
R410A Tons of CO2 equivalent A/B	tCO2e	16,7 / -	21,9 / -	25,1 / -	37,6 / -	25,1 / 25,1	31,3 / 31,3	31,3 / 31,3	35,5 / 35,5	43,8 / 43,8	43,8 / 43,8	48,0 / 45,9	66,8 / 66,8	71,0 / 71,0
50/48UCV R410A Charge: Circuit A - Circuit B	kg	8,0 / -	10,5 / -	12,0 / -	15,0 / -	12,0 / 12,0	15,5 / 15,5	15,5 / 15,5	15,0 / 17,0	19,0 / 21,0	23,0 / 21,0	23,0 / 22,0	30,0 / 30,0	34,0 / 34,0
R410A Tons of CO2 equivalent A/B	tCO2e	16,7 / -	21,9 / -	25,1 / -	31,3 / -	25,1 / 25,1	32,4 / 32,4	32,4 / 32,4	31,3 / 35,5	39,7 / 43,8	43,8 / 43,8	48,0 / 45,9	62,6 / 62,6	71,0 / 71,0
50/48UC- R410A Charge: Circuit A - Circuit B	kg	8,0 / -	10,5 / -	12,0 / -	18,0 / -	12,0 / 12,0	15,5 / 15,5	15,5 / 15,5	17,0 / 17,0	21,0 / 21,0	21,0 / 21,0	23,0 / 22,0	32,0 / 32,0	34,0 / 34,0
R410A Tons of CO2 equivalent A/B	tCO2e	16,7 / -	21,9 / -	25,1 / -	37,6 / -	25,1 / 25,1	32,4 / 32,4	32,4 / 32,4	35,5 / 35,5	43,8 / 43,8	43,8 / 43,8	48,0 / 45,9	66,8 / 66,8	71,0 / 71,0
50/48UPV R454B Charge: Circuit A - Circuit B	kg	7,0 / -	9,5 / -	11,0 / -	13,5 / -	11,0 / 11,0	13,5 / 13,5	13,5 / 13,5	- / -	17,0 / 19,0	21,0 / 19,0	21,0 / 20,0	26,5 / 26,5	28,0 / 28,0
R454B Tons of CO2 equivalent A/B	tCO2e	3,3 / -	4,4 / -	5,1 / -	6,3 / -	5,1 / 5,1	6,3 / 6,3	6,3 / 6,3	- / -	7,9 / 8,9	9,8 / 8,9	9,8 / 9,3	12,3 / 12,3	13,0 / 13,0
50/48UP- R454B Charge: Circuit A - Circuit B	kg	7,0 / -	9,5 / -	11,0 / -	16,5 / -	11,0 / 11,0	13,5 / 13,5	13,5 / 13,5	- / -	19,0 / 19,0	19,0 / 19,0	21,0 / 20,0	26,5 / 26,5	28,0 / 28,0
R454B Tons of CO2 equivalent A/B	tCO2e	3,3 / -	4,4 / -	5,1 / -	7,7 / -	5,1 / 5,1	6,3 / 6,3	6,3 / 6,3	- / -	8,9 / 8,9	8,9 / 8,9	9,8 / 9,3	12,3 / 12,3	13,0 / 13,0
50/48UCV R454B Charge: Circuit A - Circuit B	kg	7,0 / -	9,5 / -	11,0 / -	13,5 / -	11,0 / 11,0	14,0 / 14,0	14,0 / 14,0	- / -	17,0 / 19,0	21,0 / 19,0	21,0 / 20,0	26,5 / 26,5	28,0 / 28,0
R454B Tons of CO2 equivalent A/B	tCO2e	3,3 / -	4,4 / -	5,1 / -	6,3 / -	5,1 / 5,1	6,5 / 6,5	6,5 / 6,5	- / -	7,9 / 8,9	9,8 / 8,9	9,8 / 9,3	12,3 / 12,3	13,0 / 13,0
50/48UC- R454B Charge: Circuit A - Circuit B	kg	7,0 / -	9,5 / -	11,0 / -	16,5 / -	11,0 / 11,0	14,0 / 14,0	14,0 / 14,0	- / -	19,0 / 19,0	19,0 / 19,0	21,0 / 20,0	26,5 / 26,5	28,0 / 28,0
R454B Tons of CO2 equivalent A/B	tCO2e	3,3 / -	4,4 / -	5,1 / -	7,7 / -	5,1 / 5,1	6,5 / 6,5	6,5 / 6,5	- / -	8,9 / 8,9	8,9 / 8,9	9,8 / 9,3	12,3 / 12,3	13,0 / 13,0
<b>Indoor Coil</b>														
Material		Cu / Al	Cu / Al	Cu / Al	Cu / Al	Cu / Al	Cu / Al	Cu / Al	Cu / Al	Cu / Al	Cu / Al	Cu / Al	Cu / Al	Cu / Al
Coil Type		3/8" RTPF	3/8" RTPF	3/8" RTPF	3/8" RTPF	3/8" RTPF	3/8" RTPF	3/8" RTPF	3/8" RTPF	3/8" RTPF	3/8" RTPF	3/8" RTPF	3/8" RTPF	3/8" RTPF
Rows / FPI		2 / 16	3 / 16	3 / 16	4 / 16	3 / 16	4 / 16	4 / 16	4 / 16	5 / 16	5 / 16	5 / 16	4 / 16	5 / 16
Condensate Drain Connection Size	mm	34	34	34	34	34	34	34	34	34	34	34	34	34
<b>Outdoor Coil</b>														
Material		Cu / Al	Cu / Al	Cu / Al	Cu / Al	Cu / Al	Cu / Al	Cu / Al	Cu / Al	Cu / Al	Cu / Al	Cu / Al	Cu / Al	Cu / Al
Coil Type		3/8" RTPF	3/8" RTPF	3/8" RTPF	3/8" RTPF	3/8" RTPF	3/8" RTPF	3/8" RTPF	3/8" RTPF	3/8" RTPF	3/8" RTPF	3/8" RTPF	3/8" RTPF	3/8" RTPF
Rows / FPI		2 / 16	2 / 16	2 / 16	3 / 16	2 / 16	3 / 16	3 / 16	3 / 16	4 / 16	4 / 16	3 / 16	3 / 16	4 / 16

\*\*\*\*Natural gas (G20) net calorific value 34,02 MJ/m<sup>3</sup> @ 15°C, 1,013 mbar.  
 \*\*\*\*\*Weight and power input values are valid for the heating modules.

## 6 - ELECTRICAL DATA

50/48 UCV*	Unit	025	035	045	055	65	75	90	105	125	140	160	190	220
<b>Power Circuit</b>														
Nominal Power Supply	V-Ph-Hz	400-3-50												
Voltage Range	V	360-440												
Control Circuit Supply		24 V, via Internal Transformer												
Maximum Start-up Current**	A	20	24	35	42	120	138	154	195	217	248	270	319	332
Unit Power Factor at Maximum Capacity***		0,99	0,9	0,91	0,91	0,83	0,88	0,85	0,8	0,79	0,8	0,79	0,78	0,78
Maximum Input Power***	kW	12,75	14,54	21,47	25,97	27,9	37,37	38,79	49,09	52,99	69,8	75,96	83,84	89,8
Nominal Input Current****	A	10,08	16,22	22,06	27,37	32,45	36,94	45,00	63,50	68,47	78,24	90,72	109,73	115,84
Maximum Input Current*****	A	18,60	23,20	34,00	41,30	48,3	61,2	66,3	88,9	96,4	125,4	139,5	154,21	167,02
Customer Control Connection	V	24												
50/48 UC.*	Unit	025	035	045	055	065	075	090	105	125	140	160	190	220
<b>Power Circuit</b>														
Nominal Power Supply	V-Ph-Hz	400-3-50												
Voltage Range	V	360-440												
Control Circuit Supply		24 V, via Internal Transformer												
Maximum Start-up Current**	A	148	153	206	151	125	135	156	206	233	250	278	338	364
Unit Power Factor at Maximum Capacity***		0,70	0,70	0,69	0,69	0,77	0,85	0,77	0,68	0,69	0,68	0,68	0,68	0,68
Maximum Input Power***	kW	13,33	16,08	21,11	25,18	28,42	34,30	37,14	47,84	54,04	61,36	70,28	82,74	94,66
Nominal Input Current****	A	16,21	21,86	28,96	36,62	34,80	37,83	48,24	75,70	82,62	94,59	106,80	121,59	139,78
Maximum Input Current*****	A	27,40	33,40	44,30	52,80	53,40	58,50	69,50	101,10	113,60	129,60	150,10	174,70	200,70
Customer Control Connection	V	24												
50/48 UPV*	Unit	025	035	045	055	65	75	90	105	125	140	160	190	220
<b>Power Circuit</b>														
Nominal Power Supply	V-Ph-Hz	400-3-50												
Voltage Range	V	360-440												
Control Circuit Supply		24 V, via Internal Transformer												
Maximum Start-up Current**	A	20	24	35	42	120	138	154	195	217	248	270	319	332
Unit Power Factor at Maximum Capacity***		0,99	0,9	0,91	0,91	0,83	0,88	0,85	0,80	0,79	0,80	0,79	0,78	0,78
Maximum Input Power***	kW	12,75	14,54	21,47	25,97	27,90	37,37	38,79	49,09	52,99	69,80	75,96	83,84	89,80
Nominal Input Current****	A	32,67	53,40	66,36	83,72	111,30	125,97	144,00	179,70	225,28	248,80	286,67	109,73	115,84
Maximum Input Current*****	A	18,60	23,20	34,00	41,30	48,30	61,20	66,30	88,90	96,40	125,40	139,50	154,21	167,02
Customer Control Connection	V	24												
50/48 UP.*	Unit	025	035	045	055	065	075	090	105	125	140	160	190	220
<b>Power Circuit</b>														
Nominal Power Supply	V-Ph-Hz	400-3-50												
Voltage Range	V	360-440												
Control Circuit Supply		24 V, via Internal Transformer												
Maximum Start-up Current**	A	148	153	206	151	125	135	156	206	233	250	278	338	364
Unit Power Factor at Maximum Capacity***		0,70	0,70	0,69	0,69	0,77	0,85	0,77	0,68	0,69	0,68	0,68	0,68	0,68
Maximum Input Power***	kW	13,33	16,08	21,11	25,18	28,42	34,30	37,14	47,84	54,04	61,36	70,28	82,74	94,66
Nominal Input Current****	A	16,21	21,86	28,96	36,62	34,80	37,83	48,60	75,70	82,62	94,59	106,80	121,59	139,78
Maximum Input Current*****	A	27,40	33,40	44,30	52,80	53,40	58,50	69,50	101,10	113,60	129,60	150,10	174,70	200,70
Customer Control Connection	V	24												

\*Standard unit (without any options and accessories)

\*\*Maximum instantaneous start-up current at operating limit values (maximum operating current of the smallest compressor(s) + fan current + locked rotor current of the largest compressor).

\*\*\*Power input, compressors and fans, at their operating limits and nominal voltage of 400 V (data given on the unit nameplate).

\*\*\*\*Standardised Eurovent conditions: indoor air wet bulb 19 °C, outside air temperature 35 °C with standard fan performance

\*\*\*\*\*Maximum unit operating current at maximum unit power input and 400 V (values given on the unit nameplate).

### Electrical data notes and operating conditions

- 50/48 UC-(V)/UP-(V) units have a single power connection point located at the main switch
  - The control box includes the following standard features:
    - a main disconnect switch,
    - starter and motor protection devices for each compressor, fans and electric heater option,
    - the control devices.
  - Field connections:
    - All connections to the system and the electrical installations must be in full accordance with all applicable local codes.
    - The Carrier 50/48 UC-(V)/UP-(V) units are designed and built to ensure conformance with these codes.
- The recommendations of European standard EN 60204-1 (machine safety
- electrical machine components. Part 1: general regulations – corresponds to IEC 60204-1) are specifically taken into account, when designing the electrical equipment.

### Notes:

- Generally the recommendations of IEC 60364 are accepted as compliance with the requirements of the installation directives. Conformance with EN 60204 is the best means of ensuring compliance with the Machines Directive §1.5.1.
  - Annex B of EN 60204-1 describes the electrical characteristics used for the operation of the machines.
- \* +48°C for UCV/UPV 025, 035, 045, 055, 065, 075, 090, 105, 125, 140, 160, 190 and 220 sizes

\* +50°C for UC-/UP- 025, 035, 045, 055, 105, 125 and 140 sizes

\* +51°C for UC-/UP- 190 and 220

### 1. The operating environment is specified below:

- a) Environment as classified in EN 60721 (corresponds to IEC 60721):
    - outdoor installation (IP43),
    - ambient temperature range: -20°C to +52°C\*,
    - altitude: ≤ 2.000 m,
  - b) Competence of personnel. Class BA4 (trained personnel – IEC 60364)
2. Power supply frequency variation: ± 2 Hz.
  3. The neutral (N) conductor must not be connected directly to the unit (if necessary use a transformer).
  4. Overcurrent protection of the power supply conductors is not provided with the unit.
  5. The factory-installed disconnect switch(es)/circuit breaker(s) is(are) of a type suitable for power interruption in accordance with EN 60947.
  6. The units are designed for connection to TN networks (IEC 60364). For IT networks the earth connection must not be at the network earth. Provide a local earth, consult competent local organisations to complete the electrical installation.

### CAUTION:

**If particular aspects of an actual installation do not conform to the conditions described above, or if there are other conditions which should be considered, always contact your local Carrier representative.**

## 7 - APPLICATION DATA

### 7.1 - Air Filter Replacement

Open the filter access panel, then remove and replace the filters by sliding them from the rails. Check the filter fire classification according to local regulations..

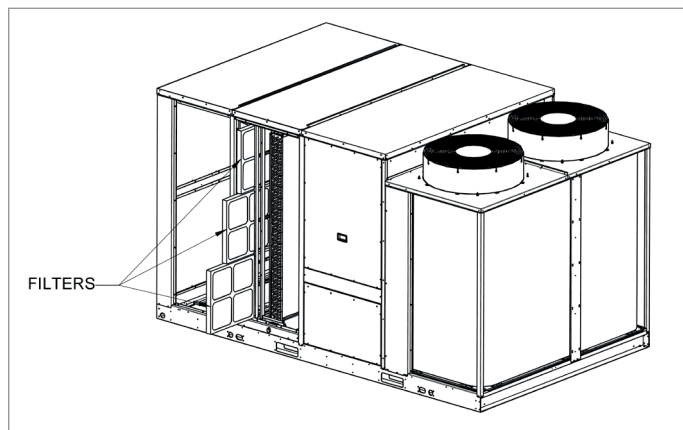

Fig. 6 – Filter replacement

## 7.2 - Fan Performance, 50/48 UC-(V)/UP-(V) 025

Unit with Standard Static Pressure

Air Flow Rate (m³/h)	Unit External Static Pressure (Pa)																										
	50		150		250		350		450		550		650		750		850		950		1.050		1.150		1.250		
	rpm	kW	rpm	kW	rpm	kW	rpm	kW	rpm	kW	rpm	kW	rpm	kW	rpm	kW	rpm	kW	rpm	kW	rpm	kW	rpm	kW	rpm	kW	rpm
3.240	1.001	0,20	1.180	0,32	1.339	0,46	1.482	0,60	1.614	0,76	1.736	0,92	1.850	1,08	1.960	1,26	2.067	1,43	2.168	1,63	2.265	1,82	2.359	2,01	2.452	2,22	
3.420	1.042	0,22	1.215	0,34	1.370	0,49	1.509	0,63	1.639	0,80	1.759	0,95	1.871	1,12	1.978	1,31	2.082	1,48	2.182	1,68	2.278	1,88	2.370	2,07	2.463	2,28	
3.600	1.082	0,24	1.249	0,37	1.400	0,51	1.536	0,66	1.663	0,83	1.782	0,98	1.892	1,16	1.997	1,35	2.097	1,53	2.196	1,74	2.290	1,93	2.383	2,13	2.473	2,34	
3.780	1.124	0,26	1.285	0,40	1.432	0,54	1.565	0,69	1.689	0,87	1.806	1,02	1.915	1,21	2.018	1,39	2.116	1,59	2.211	1,80	2.305	1,99	2.397	2,20			
3.960	1.166	0,27	1.321	0,43	1.464	0,56	1.594	0,73	1.716	0,90	1.831	1,06	1.939	1,26	2.040	1,44	2.137	1,64	2.230	1,86	2.320	2,05	2.415	2,29			
4.140	1.209	0,29	1.358	0,46	1.498	0,59	1.624	0,76	1.744	0,93	1.856	1,11	1.963	1,31	2.064	1,49	2.159	1,70	2.251	1,91	2.339	2,12	2.429	2,35			
4.320	1.251	0,32	1.394	0,48	1.529	0,63	1.653	0,80	1.770	0,96	1.881	1,16	1.987	1,35	2.087	1,54	2.181	1,75	2.271	1,96	2.359	2,18	2.448	2,42			
4.500	1.295	0,34	1.433	0,51	1.563	0,67	1.684	0,83	1.799	0,99	1.908	1,20	2.012	1,40	2.111	1,60	2.205	1,81	2.294	2,02	2.381	2,25	2.467	2,49			
4.680	1.338	0,37	1.473	0,53	1.597	0,71	1.716	0,87	1.828	1,03	1.936	1,25	2.038	1,45	2.135	1,66	2.229	1,88	2.317	2,08	2.404	2,32					
4.860	1.382	0,40	1.512	0,56	1.631	0,75	1.747	0,91	1.858	1,08	1.964	1,29	2.065	1,49	2.160	1,72	2.253	1,94	2.341	2,15	2.427	2,39					
5.040	1.426	0,43	1.551	0,60	1.666	0,79	1.780	0,94	1.889	1,13	1.993	1,34	2.093	1,54	2.187	1,78	2.278	2,00	2.365	2,22	2.450	2,46					
5.220	1.469	0,45	1.590	0,64	1.702	0,83	1.812	0,98	1.920	1,18	2.023	1,39	2.121	1,60	2.214	1,84	2.303	2,06	2.390	2,30							

## 7.3 - Fan Performance, 50/48 UC-(V)/UP-(V) 035

Unit with Standard Static Pressure

Air Flow Rate (m³/h)	Unit External Static Pressure (Pa)																									
	50		150		250		350		450		550		650		750		850		950		1050					
	rpm	kW	rpm	kW	rpm	kW	rpm	kW	rpm	kW	rpm	kW	rpm	kW	rpm	kW	rpm	kW	rpm	kW	rpm	kW	rpm	kW		
4.500	1.312	0,36	1.448	0,53	1.578	0,69	1.698	0,85	1.812	1,01	1.921	1,23	2.024	1,42	2.122	1,62	2.216	1,84	2.304	2,05	2.391	2,28				
4.752	1.373	0,40	1.504	0,57	1.626	0,74	1.743	0,90	1.854	1,08	1.961	1,29	2.061	1,49	2.157	1,71	2.250	1,93	2.338	2,14	2.423	2,37				
5.004	1.435	0,44	1.559	0,62	1.675	0,80	1.788	0,96	1.897	1,15	2.001	1,36	2.100	1,56	2.194	1,80	2.285	2,02	2.372	2,24	2.457	2,48				
5.256	1.496	0,48	1.615	0,67	1.725	0,86	1.835	1,02	1.941	1,22	2.043	1,42	2.140	1,65	2.232	1,88	2.320	2,11	2.407	2,35						
5.508	1.557	0,53	1.670	0,73	1.776	0,91	1.882	1,10	1.986	1,30	2.085	1,49	2.180	1,73	2.272	1,97	2.358	2,20	2.441	2,45						
5.760	1.618	0,59	1.726	0,78	1.829	0,97	1.930	1,18	2.031	1,37	2.129	1,59	2.222	1,82	2.312	2,05	2.397	2,30								
6.012	1.679	0,64	1.782	0,83	1.882	1,04	1.979	1,26	2.078	1,45	2.173	1,68	2.264	1,91	2.352	2,15	2.436	2,40								
6.264	1.741	0,70	1.839	0,89	1.935	1,11	2.029	1,34	2.125	1,55	2.218	1,78	2.308	2,01	2.394	2,25										
6.516	1.803	0,75	1.895	0,97	1.989	1,19	2.080	1,41	2.172	1,65	2.264	1,88	2.351	2,11	2.436	2,35										
6.768	1.865	0,81	1.952	1,05	2.042	1,26	2.132	1,49	2.220	1,76	2.310	1,98	2.395	2,22												
7.020	1.927	0,89	2.010	1,12	2.097	1,33	2.186	1,59	2.270	1,86	2.358	2,09	2.440	2,33												
7.272	1.988	0,96	2.068	1,19	2.152	1,43	2.239	1,69	2.322	1,95	2.404	2,21														

## 7.4 - Fan Performances, 50/48 UC-(V)/UP-(V) 045

Unit with Standard Static Pressure

Air Flow Rate (m³/h)	Unit External Static Pressure (Pa)																									
	50		150		250		350		450		550		650		750		850		950							
	rpm	kW	rpm	kW	rpm	kW	rpm	kW	rpm	kW	rpm	kW	rpm	kW	rpm	kW	rpm	kW	rpm	kW	rpm	kW				
5.400	1.127	0,40	1.235	0,58	1.350	0,78	1.462	0,98	1.565	1,20	1.660	1,39	1.750	1,63	1.835	1,86	1.918	2,11	1.996	2,39						
5.760	1.190	0,45	1.291	0,65	1.400	0,85	1.507	1,07	1.607	1,30	1.701	1,52	1.788	1,75	1.871	1,97	1.952	2,25	2.030	2,52						
6.120	1.252	0,51	1.347	0,71	1.450	0,91	1.551	1,16	1.650	1,38	1.740	1,64	1.826	1,87	1.908	2,11	1.988	2,38	2.064	2,65						
6.480	1.314	0,58	1.405	0,78	1.502	1,00	1.597	1,25	1.692	1,49	1.782	1,76	1.866	2,00	1.946	2,27	2.024	2,53	2.099	2,79						
6.840	1.377	0,65	1.465	0,85	1.556	1,10	1.646	1,33	1.737	1,60	1.825	1,86	1.907	2,15	1.987	2,43	2.063	2,69	2.136	2,93						
7.200	1.438	0,72	1.524	0,95	1.610	1,19	1.697	1,44	1.783	1,72	1.868	1,97	1.950	2,28	2.026	2,58	2.101	2,84								
7.560	1.502	0,81	1.585	1,04	1.666	1,29	1.749	1,55	1.831	1,83	1.913	2,11	1.993	2,42	2.069	2,72	2.141	3,00								
7.920	1.565	0,90	1.646	1,13	1.723	1,41	1.803	1,67	1.882	1,94	1.959	2,27	2.036	2,57	2.111	2,86										
8.280	1.627	0,99	1.707	1,23	1.780	1,52	1.856	1,79	1.932	2,09	2.007	2,41	2.080	2,71												
8.640	1.690	1,09	1.769	1,36	1.839	1,64	1.910	1,92	1.985	2,24	2.056	2,55	2.127	2,86												
9.000	1.754	1,21	1.831	1,48	1.898	1,76	1.967	2,09	2.038	2,39	2.107	2,70														
9.360	1.818	1,34	1.894	1,61	1.959	1,91	2.024	2,24	2.093	2,55																



### 7.5 - Fan Performances, 50/48 UCV/UPV 055

Unit with Standard Static Pressure

Air Flow Rate (m³/h)	Unit External Static Pressure (Pa)																	
	50		150		250		350		450		550		650		750		850	
	rpm	kW	rpm	kW	rpm	kW	rpm	kW	rpm	kW	rpm	kW	rpm	kW	rpm	kW	rpm	kW
7.200	839	0,58	944	0,84	1.043	1,11	1.133	1,41	1.215	1,71	1.291	2,03	1.363	2,35	1.432	2,70	1.500	3,08
7.560	871	0,63	971	0,91	1.067	1,17	1.155	1,50	1.237	1,80	1.312	2,15	1.382	2,46	1.450	2,83	1.517	3,20
7.920	902	0,68	998	0,97	1.092	1,26	1.178	1,59	1.259	1,90	1.333	2,25	1.402	2,59	1.470	2,97	1.535	3,33
8.280	932	0,74	1.025	1,04	1.116	1,34	1.200	1,67	1.280	2,01	1.353	2,36	1.422	2,73	1.489	3,10		
8.640	964	0,82	1.053	1,10	1.141	1,43	1.225	1,76	1.302	2,12	1.375	2,47	1.443	2,86	1.508	3,24		
9.000	996	0,89	1.083	1,18	1.168	1,53	1.249	1,86	1.325	2,24	1.397	2,60	1.465	3,00	1.529	3,38		
9.360	1.028	0,96	1.112	1,27	1.194	1,62	1.274	1,97	1.348	2,35	1.419	2,74	1.486	3,13				
9.720	1.059	1,03	1.141	1,36	1.221	1,71	1.298	2,08	1.371	2,46	1.441	2,88	1.508	3,27				
10.080	1.091	1,10	1.170	1,46	1.247	1,81	1.322	2,19	1.394	2,58	1.463	3,01	1.529	3,40				
10.440	1.122	1,19	1.200	1,55	1.274	1,92	1.346	2,30	1.417	2,71	1.486	3,14						
10.800	1.154	1,29	1.230	1,64	1.302	2,03	1.371	2,42	1.441	2,85	1.509	3,27						
11.160	1.185	1,38	1.259	1,74	1.329	2,14	1.397	2,54	1.465	2,98	1.531	3,40						

### 7.6 - Fan Performance, 50/48 UC-(V)/UP-(V) 065

Unit with Standard Static Pressure

Air Flow Rate (m³/h)	Unit External Static Pressure (Pa)																	
	50		150		250		350		450		550		650		750		850	
	rpm	kW	rpm	kW	rpm	kW	rpm	kW	rpm	kW	rpm	kW	rpm	kW	rpm	kW	rpm	kW
8.100	843	0,52	942	0,79	1.035	1,08	1.127	1,39	1.211	1,71	1.289	2,05	1.361	2,39	1.430	2,76	1.496	3,13
8.532	881	0,58	977	0,86	1.066	1,15	1.155	1,49	1.236	1,81	1.313	2,18	1.385	2,52	1.453	2,91	1.518	3,28
8.964	919	0,63	1.010	0,94	1.097	1,24	1.182	1,58	1.262	1,93	1.337	2,30	1.409	2,67	1.476	3,06		
9.396	957	0,71	1.045	1,02	1.129	1,34	1.211	1,68	1.289	2,05	1.362	2,42	1.433	2,82	1.500	3,21		
9.828	996	0,79	1.081	1,09	1.162	1,44	1.241	1,79	1.316	2,17	1.388	2,55	1.458	2,98	1.524	3,37		
10.260	1.034	0,86	1.117	1,20	1.195	1,54	1.270	1,92	1.343	2,30	1.414	2,70	1.483	3,13				
10.692	1.073	0,94	1.153	1,30	1.229	1,65	1.301	2,04	1.371	2,42	1.441	2,85	1.509	3,28				
11.124	1.111	1,03	1.189	1,40	1.262	1,77	1.332	2,16	1.400	2,57	1.469	3,00	1.535	3,43				
11.556	1.148	1,13	1.224	1,50	1.295	1,90	1.363	2,28	1.430	2,72	1.496	3,16						
11.988	1.186	1,24	1.260	1,61	1.329	2,04	1.396	2,41	1.461	2,88	1.525	3,32						
12.420	1.223	1,34	1.297	1,75	1.363	2,16	1.428	2,58	1.492	3,03								
12.852	1.260	1,45	1.334	1,88	1.398	2,29	1.461	2,75	1.523	3,18								

### 7.7 - Fan Performance, 50/48 UC-(V)/UP-(V) 075

Unit with Standard Static Pressure

Air Flow Rate (m³/h)	Unit External Static Pressure (Pa)															
	50		150		250		350		450		550		650		750	
	rpm	kW	rpm	kW	rpm	kW	rpm	kW	rpm	kW	rpm	kW	rpm	kW	rpm	kW
8.892	920	0,64	1.012	0,95	1.098	1,26	1.184	1,59	1.264	1,94	1.339	2,31	1.410	2,67	1.477	3,07
9.360	962	0,73	1.050	1,03	1.134	1,37	1.216	1,70	1.293	2,07	1.366	2,45	1.437	2,84	1.503	3,23
9.828	1.004	0,81	1.088	1,13	1.169	1,48	1.247	1,83	1.323	2,21	1.395	2,59	1.464	3,01	1.529	3,40
10.296	1.047	0,90	1.128	1,24	1.206	1,59	1.280	1,97	1.353	2,34	1.424	2,76	1.492	3,19		
10.764	1.088	0,98	1.166	1,35	1.242	1,70	1.313	2,10	1.383	2,48	1.453	2,92	1.520	3,34		
11.232	1.130	1,10	1.206	1,47	1.279	1,84	1.348	2,24	1.415	2,66	1.483	3,09				
11.700	1.170	1,22	1.245	1,58	1.315	1,99	1.382	2,37	1.448	2,83	1.514	3,26				
12.168	1.211	1,33	1.284	1,72	1.351	2,14	1.417	2,54	1.482	2,99						
12.636	1.251	1,44	1.324	1,87	1.389	2,28	1.453	2,72	1.516	3,17						
13.104	1.294	1,59	1.365	2,02	1.428	2,45	1.490	2,91								
13.572	1.337	1,75	1.406	2,17	1.468	2,65	1.528	3,10								
14.040	1.380	1,90	1.447	2,36	1.507	2,83										

Unit with High Static Pressure (Option 151)

Air Flow Rate (m³/h)	Unit External Static Pressure (Pa)																					
	50		150		250		350		450		550		650		750		850		950		1050	
	rpm	kW	rpm	kW	rpm	kW	rpm	kW	rpm	kW	rpm	kW	rpm	kW	rpm	kW	rpm	kW	rpm	kW	rpm	kW
8.892	1.306	0,73	1.443	1,06	1.574	1,37	1.695	1,70	1.809	2,02	1.918	2,45	2.021	2,84	2.120	3,23	2.213	3,66	2.302	4,07	2.389	4,53
9.360	1.366	0,81	1.497	1,13	1.621	1,48	1.739	1,80	1.850	2,15	1.957	2,58	2.057	2,98	2.154	3,41	2.247	3,83	2.335	4,25	2.421	4,72
9.828	1.426	0,89	1.551	1,24	1.669	1,60	1.783	1,91	1.892	2,29	1.997	2,71	2.095	3,12	2.190	3,59	2.281	4,01	2.368	4,45	2.453	4,92
10.296	1.487	0,97	1.606	1,35	1.718	1,72	1.829	2,03	1.936	2,44	2.038	2,84	2.135	3,29	2.228	3,76	2.317	4,19	2.403	4,66		
10.764	1.546	1,07	1.659	1,46	1.767	1,83	1.875	2,18	1.979	2,58	2.079	2,98	2.175	3,46	2.266	3,92	2.352	4,39	2.437	4,87		
11.232	1.606	1,19	1.715	1,57	1.819	1,94	1.923	2,35	2.025	2,74	2.123	3,16	2.216	3,64	2.306	4,09	2.391	4,59				
11.700	1.665	1,31	1.770	1,68	1.871	2,09	1.971	2,51	2.070	2,89	2.166	3,35	2.258	3,82	2.346	4,28	2.430	4,78				
12.168	1.724	1,42	1.825	1,79	1.923	2,24	2.019	2,67	2.116	3,07	2.210	3,55	2.300	4,00	2.386	4,48	2.469	4,98				
12.636	1.785	1,54	1.880	1,95	1.976	2,40	2.068	2,84	2.164	3,28	2.256	3,75	2.344	4,20	2.428	4,69						
13.104	1.845	1,65	1.936	2,11	2.029	2,55	2.119	3,02	2.212	3,50	2.302	3,95	2.388	4,42	2.471	4,91						
13.572	1.905	1,82	1.992	2,27	2.083	2,71	2.172	3,22	2.261	3,72	2.349	4,16	2.432	4,65								
14.040	1.964	1,98	2.048	2,43	2.136	2,88	2.224	3,42	2.309	3,93	2.394	4,40										

**7.8 - Fan Performance, 50/48 UC-(V)/UP-(V) 090**

Unit with Standard Static Pressure

Air Flow Rate (m³/h)	Unit External Static Pressure (Pa)													
	50		150		250		350		450		550		650	
	rpm	kW	rpm	kW	rpm	kW	rpm	kW	rpm	kW	rpm	kW	rpm	kW
9.540	979	0,76	1.065	1,07	1.147	1,41	1.228	1,75	1.305	2,13	1.377	2,50	1.447	2,91
10.080	1.027	0,86	1.109	1,19	1.188	1,54	1.265	1,90	1.339	2,28	1.410	2,68	1.479	3,11
10.620	1.076	0,96	1.155	1,32	1.231	1,66	1.303	2,06	1.373	2,44	1.444	2,87	1.511	3,30
11.160	1.123	1,08	1.200	1,45	1.272	1,82	1.342	2,21	1.409	2,63	1.478	3,06		
11.700	1.170	1,22	1.245	1,58	1.315	1,99	1.382	2,37	1.448	2,83	1.514	3,26		
12.240	1.217	1,35	1.291	1,75	1.357	2,16	1.423	2,57	1.487	3,02				
12.780	1.265	1,49	1.337	1,92	1.401	2,33	1.465	2,78	1.527	3,22				
13.320	1.314	1,67	1.384	2,09	1.446	2,54	1.508	3,00						
13.860	1.364	1,85	1.432	2,28	1.492	2,76								
14.400	1.413	2,02	1.479	2,51										
14.940	1.462	2,24	1.526	2,74										
15.480	1.511	2,47												

Unit with High Static Pressure (Option 151)

Air Flow Rate (m³/h)	Unit External Static Pressure (Pa)																			
	50		150		250		350		450		550		650		750		850		950	
	rpm	kW	rpm	kW	rpm	kW	rpm	kW	rpm	kW	rpm	kW	rpm	kW	rpm	kW	rpm	kW	rpm	kW
9.540	1.390	0,84	1.518	1,17	1.640	1,53	1.756	1,84	1.867	2,21	1.973	2,63	2.072	3,02	2.168	3,48	2.260	3,90	2.348	4,33
10.080	1.459	0,93	1.580	1,30	1.695	1,66	1.807	1,96	1.915	2,37	2.019	2,78	2.117	3,21	2.209	3,68	2.300	4,10	2.387	4,56
10.620	1.528	1,03	1.643	1,43	1.752	1,80	1.861	2,14	1.966	2,54	2.067	2,93	2.163	3,40	2.254	3,87	2.341	4,33	2.427	4,81
11.160	1.596	1,17	1.706	1,55	1.810	1,93	1.915	2,32	2.017	2,71	2.116	3,13	2.209	3,61	2.299	4,07	2.385	4,55	2.467	5,05
11.700	1.665	1,31	1.770	1,68	1.871	2,09	1.971	2,51	2.070	2,89	2.166	3,35	2.258	3,82	2.346	4,28	2.430	4,78		
12.240	1.734	1,44	1.834	1,81	1.932	2,27	2.027	2,70	2.124	3,11	2.218	3,58	2.307	4,03	2.393	4,52				
12.780	1.803	1,58	1.898	2,00	1.992	2,45	2.084	2,89	2.179	3,35	2.270	3,81	2.358	4,27	2.442	4,76				
13.320	1.873	1,73	1.962	2,19	2.054	2,62	2.144	3,11	2.235	3,60	2.324	4,05	2.409	4,53						
13.860	1.942	1,92	2.027	2,37	2.116	2,81	2.204	3,35	2.291	3,85	2.377	4,31	2.460	4,78						
14.400	2.010	2,10	2.092	2,56	2.179	3,04	2.265	3,58	2.347	4,10	2.431	4,58								
14.940	2.078	2,29	2.157	2,78	2.242	3,28	2.325	3,80	2.405	4,37										
15.480	2.148	2,48	2.223	3,02	2.305	3,51	2.387	4,04	2.464	4,62										

**7.9 - Fan Performance, 50/48 UC-(V)/UP-(V) 105**

Unit with Standard Static Pressure

Air Flow Rate (m³/h)	Unit External Static Pressure (Pa)																	
	50		150		250		350		450		550		650		750		850	
	rpm	kW	rpm	kW	rpm	kW	rpm	kW	rpm	kW	rpm	kW	rpm	kW	rpm	kW	rpm	kW
11.520	1.648	1,25	1.757	1,62	1.862	2,03	1.967	2,43	2.070	2,81	2.169	3,27	2.263	3,74	2.353	4,21	2.439	4,71
12.060	1.716	1,37	1.820	1,74	1.922	2,19	2.022	2,61	2.122	3,02	2.219	3,49	2.311	3,94	2.399	4,43		
12.600	1.786	1,51	1.885	1,92	1.984	2,37	2.080	2,80	2.178	3,26	2.272	3,72	2.362	4,18	2.448	4,67		
13.140	1.855	1,65	1.949	2,10	2.044	2,54	2.137	3,02	2.232	3,49	2.324	3,94	2.412	4,42				
13.680	1.924	1,83	2.014	2,28	2.106	2,71	2.197	3,25	2.288	3,73	2.377	4,19	2.463	4,67				
14.220	1.992	2,01	2.078	2,46	2.169	2,94	2.257	3,48	2.345	3,98	2.430	4,46						
14.760	2.062	2,20	2.144	2,67	2.232	3,18	2.319	3,70	2.401	4,26								
15.300	2.130	2,37	2.210	2,90	2.295	3,40	2.379	3,93	2.459	4,52								
15.840	2.200	2,60	2.276	3,13	2.359	3,63	2.440	4,18										
16.380	2.270	2,84	2.343	3,37	2.424	3,88												
16.920	2.341	3,07	2.412	3,61														
17.460	2.411	3,30																

Unit with High Static Pressure (Option 151)

Air Flow Rate (m³/h)	Unit External Static Pressure (Pa)																							
	50		150		250		350		450		550		650		750		850		950		1050		1150	
	rpm	kW	rpm	kW	rpm	kW	rpm	kW	rpm	kW	rpm	kW	rpm	kW	rpm	kW	rpm	kW	rpm	kW	rpm	kW	rpm	kW
11.520	1.642	1,24	1.752	1,62	1.861	2,03	1.966	2,48	2.069	2,87	2.167	3,30	2.262	3,77	2.353	4,21	2.440	4,72	2.524	5,26	2.605	5,79	2.683	6,29
12.060	1.709	1,37	1.814	1,75	1.920	2,20	2.022	2,65	2.121	3,06	2.218	3,53	2.311	3,98	2.400	4,44	2.485	4,99	2.567	5,52	2.646	6,03	2.724	6,54
12.600	1.777	1,50	1.879	1,93	1.981	2,38	2.080	2,82	2.176	3,31	2.271	3,77	2.362	4,21	2.448	4,73	2.532	5,27	2.612	5,79	2.690	6,29		
13.140	1.845	1,64	1.942	2,12	2.042	2,55	2.138	3,01	2.231	3,55	2.323	4,00	2.412	4,47	2.497	5,02	2.579	5,55	2.659	6,06	2.735	6,56		
13.680	1.916	1,83	2.007	2,31	2.103	2,73	2.198	3,25	2.288	3,77	2.377	4,24	2.464	4,78	2.547	5,31	2.627	5,83	2.706	6,34				
14.220	1.987	2,02	2.073	2,50	2.165	2,95	2.258	3,47	2.346	3,99	2.431	4,54	2.516	5,08	2.597	5,61	2.676	6,12						
14.760	2.059	2,21	2.140	2,69	2.229	3,20	2.319	3,71	2.405	4,23	2.487	4,85	2.569	5,40	2.649	5,91	2.727	6,41						
15.300	2.129	2,39	2.207	2,92	2.293	3,43	2.380	3,93	2.463	4,52	2.543	5,13	2.623	5,71	2.701	6,21								
15.840	2.200	2,62	2.275	3,15	2.357	3,67	2.441	4,21	2.522	4,81	2.601	5,42	2.678	6,01										
16.380	2.270	2,87	2.344	3,39	2.422	3,92	2.503	4,52	2.582	5,11	2.659	5,70	2.735	6,29										
16.920	2.340	3,11	2.412	3,63	2.487	4,24	2.565	4,82	2.642	5,41	2.718	5,99												
17.460	2.410	3,36	2.480	3,92	2.552	4,56	2.628	5,13	2.703	5,70														

**7.10- Fan Performance, 50/48 UC-(V)/UP-(V) 125**

Unit with Standard Static Pressure

Air Flow Rate (m³/h)	Unit External Static Pressure (Pa)													
	50		150		250		350		450		550		650	
	rpm	kW	rpm	kW	rpm	kW	rpm	kW	rpm	kW	rpm	kW	rpm	kW
15.480	984	1,79	1.084	2,35	1.175	3,00	1.259	3,63	1.336	4,32	1.409	4,99	1.480	5,74
16.200	1.007	1,89	1.104	2,49	1.194	3,14	1.277	3,81	1.354	4,50	1.426	5,22	1.496	5,96
16.920	1.032	1,99	1.125	2,62	1.213	3,27	1.295	3,98	1.372	4,67	1.443	5,45	1.512	6,19
17.640	1.056	2,09	1.147	2,77	1.234	3,41	1.314	4,17	1.390	4,86	1.461	5,66	1.528	6,41
18.360	1.081	2,20	1.169	2,91	1.254	3,58	1.333	4,35	1.408	5,09	1.479	5,88		
19.080	1.106	2,34	1.191	3,05	1.274	3,75	1.352	4,51	1.426	5,31	1.496	6,10		
19.800	1.132	2,49	1.215	3,19	1.294	3,93	1.371	4,68	1.445	5,53	1.514	6,32		
20.520	1.158	2,64	1.239	3,32	1.315	4,11	1.391	4,86	1.464	5,74	1.533	6,55		
21.240	1.183	2,78	1.262	3,48	1.336	4,28	1.410	5,07	1.483	5,94				
21.960	1.210	2,92	1.286	3,66	1.358	4,45	1.431	5,29	1.502	6,15				
22.680	1.237	3,05	1.310	3,83	1.381	4,61	1.452	5,51	1.522	6,35				
23.400	1.262	3,20	1.334	4,01	1.404	4,80	1.473	5,73						

Unit with High Static Pressure (Option 151)

Air Flow Rate (m³/h)	Unit External Static Pressure (Pa)																					
	50		150		250		350		450		550		650		750		850		950		1050	
	rpm	kW	rpm	kW	rpm	kW	rpm	kW	rpm	kW	rpm	kW	rpm	kW	rpm	kW	rpm	kW	rpm	kW	rpm	kW
15.480	984	1,87	1.084	2,44	1.174	3,09	1.258	3,69	1.336	4,34	1.411	5,06	1.482	5,73	1.550	6,52	1.615	7,28	1.678	8,08	1.741	8,93
16.200	1.007	1,98	1.105	2,54	1.194	3,24	1.277	3,84	1.354	4,53	1.427	5,26	1.497	5,95	1.564	6,76	1.628	7,52	1.691	8,34	1.753	9,18
16.920	1.030	2,09	1.125	2,69	1.213	3,37	1.295	3,99	1.371	4,74	1.444	5,45	1.513	6,20	1.579	7,00	1.643	7,76	1.705	8,61	1.765	9,44
17.640	1.055	2,19	1.146	2,83	1.233	3,51	1.314	4,16	1.389	4,94	1.461	5,65	1.529	6,45	1.594	7,25	1.658	8,03	1.719	8,90		
18.360	1.079	2,29	1.167	2,98	1.252	3,64	1.333	4,35	1.407	5,15	1.478	5,86	1.546	6,69	1.610	7,50	1.673	8,33	1.734	9,19		
19.080	1.104	2,38	1.188	3,13	1.271	3,78	1.351	4,54	1.425	5,34	1.495	6,09	1.562	6,93	1.626	7,73	1.687	8,62	1.748	9,48		
19.800	1.129	2,52	1.211	3,27	1.292	3,92	1.371	4,73	1.444	5,52	1.513	6,34	1.580	7,18	1.643	7,98	1.704	8,91	1.763	9,79		
20.520	1.154	2,67	1.234	3,40	1.312	4,08	1.391	4,92	1.464	5,71	1.532	6,59	1.597	7,44	1.660	8,28	1.721	9,20				
21.240	1.179	2,81	1.257	3,53	1.333	4,29	1.410	5,11	1.483	5,89	1.550	6,82	1.614	7,68	1.677	8,57	1.738	9,48				
21.960	1.205	2,95	1.281	3,66	1.355	4,50	1.430	5,30	1.502	6,13	1.569	7,06	1.633	7,93	1.695	8,88	1.755	9,78				
22.680	1.231	3,10	1.306	3,80	1.378	4,69	1.451	5,51	1.522	6,37	1.589	7,29	1.652	8,20	1.713	9,18						
23.400	1.256	3,24	1.330	3,97	1.402	4,87	1.472	5,70	1.541	6,61	1.608	7,52	1.671	8,470	1.732	9,47						

**7.11- Fan Performance, 50/48 UC-(V)/UP-(V) 140**

Unit with Standard Static Pressure

Air Flow Rate (m³/h)	Unit External Static Pressure (Pa)													
	50		150		250		350		450		550		650	
	rpm	kW	rpm	kW	rpm	kW	rpm	kW	rpm	kW	rpm	kW	rpm	kW
16.740	1.025	1,96	1.120	2,59	1.208	3,24	1.290	3,94	1.367	4,62	1.438	5,39	1.508	6,13
17.550	1.052	2,07	1.143	2,74	1.231	3,39	1.311	4,14	1.387	4,83	1.458	5,63	1.526	6,38
18.360	1.081	2,20	1.169	2,91	1.254	3,58	1.333	4,35	1.408	5,09	1.479	5,88		
19.170	1.110	2,37	1.194	3,08	1.277	3,78	1.355	4,54	1.429	5,34	1.499	6,13		
19.980	1.138	2,52	1.220	3,22	1.299	3,97	1.376	4,72	1.449	5,58	1.519	6,37		
20.790	1.167	2,69	1.247	3,38	1.323	4,17	1.398	4,93	1.471	5,81				
21.600	1.197	2,85	1.274	3,57	1.347	4,36	1.421	5,17	1.492	6,04				
22.410	1.226	3,00	1.301	3,76	1.373	4,54	1.444	5,42	1.514	6,27				
23.220	1.256	3,16	1.328	3,96	1.399	4,75	1.468	5,68						
24.030	1.285	3,35	1.355	4,16	1.425	4,98	1.492	5,90						
24.840	1.315	3,55	1.383	4,36	1.452	5,23	1.518	6,13						
25.650	1.346	3,75	1.413	4,59	1.479	5,48								

Unit with High Static Pressure (Option 151)

Air Flow Rate (m³/h)	Unit External Static Pressure (Pa)																					
	50		150		250		350		450		550		650		750		850		950		1050	
	rpm	kW	rpm	kW	rpm	kW	rpm	kW	rpm	kW	rpm	kW	rpm	kW	rpm	kW	rpm	kW	rpm	kW	rpm	kW
16.740	1.024	2,07	1.120	2,65	1.208	3,33	1.290	3,95	1.367	4,68	1.439	5,40	1.508	6,14	1.575	6,94	1.639	7,69	1.701	8,54	1.762	9,37
17.550	1.051	2,18	1.143	2,81	1.230	3,49	1.311	4,13	1.387	4,91	1.458	5,62	1.526	6,41	1.592	7,21	1.655	7,99	1.717	8,85		
18.360	1.079	2,29	1.167	2,98	1.252	3,64	1.333	4,35	1.407	5,15	1.478	5,86	1.546	6,69	1.610	7,50	1.673	8,33	1.734	9,19		
19.170	1.107	2,40	1.191	3,15	1.275	3,80	1.354	4,57	1.428	5,37	1.498	6,13	1.565	6,97	1.629	7,77	1.690	8,66	1.750	9,53		
19.980	1.135	2,55	1.216	3,30	1.296	3,95	1.375	4,77	1.449	5,57	1.517	6,40	1.584	7,24	1.647	8,05	1.708	8,97	1.767	9,86		
20.790	1.163	2,72	1.242	3,45	1.320	4,16	1.397	4,99	1.471	5,78	1.538	6,67	1.604	7,53	1.667	8,39	1.727	9,30				
21.600	1.192	2,88	1.269	3,60	1.344	4,39	1.420	5,20	1.492	6,01	1.560	6,94	1.623	7,81	1.686	8,72	1.746	9,63				
22.410	1.221	3,05	1.296	3,75	1.369	4,62	1.443	5,43	1.514	6,28	1.581	7,20	1.645	8,09	1.706	9,07	1.766	9,97				
23.220	1.250	3,21	1.324	3,93	1.396	4,82	1.467	5,66	1.537	6,55	1.603	7,47	1.666	8,40	1.727	9,40						
24.030	1.278	3,37	1.352	4,15	1.422	5,03	1.490	5,89	1.559	6,82	1.625	7,72	1.688	8,71	1.748	9,70						
24.840	1.308	3,54	1.380	4,37	1.449	5,24	1.516	6,17	1.582	7,10	1.647	8,00	1.709	9,02	1.769	10,01						
25.650	1.338	3,73	1.409	4,60	1.477	5,45	1.542	6,43	1.606	7,39	1.670	8,33	1.731	9,340								

### 7.12- Fan Performance, 50/48 UC-(V)/UP-(V) 160

Unit with Standard Static Pressure

Air Flow Rate (m³/h)	Unit External Static Pressure (Pa)											
	50		150		250		350		450		550	
	rpm	kW	rpm	kW	rpm	kW	rpm	kW	rpm	kW	rpm	kW
18.540	1.087	2,24	1.174	2,95	1.259	3,62	1.337	4,39	1.412	5,14	1.483	5,94
19.440	1.119	2,42	1.203	3,12	1.284	3,84	1.361	4,59	1.435	5,42	1.505	6,21
20.340	1.151	2,60	1.232	3,28	1.310	4,06	1.386	4,80	1.459	5,69	1.528	6,49
21.240	1.183	2,78	1.262	3,48	1.336	4,28	1.410	5,07	1.483	5,94		
22.140	1.216	2,95	1.292	3,70	1.364	4,48	1.436	5,34	1.507	6,19		
23.040	1.249	3,11	1.322	3,92	1.392	4,69	1.462	5,62	1.531	6,45		
23.940	1.282	3,33	1.352	4,14	1.422	4,96	1.490	5,88				
24.840	1.315	3,55	1.383	4,36	1.452	5,23	1.518	6,13				
25.740	1.350	3,77	1.416	4,61	1.482	5,51						
26.640	1.384	3,99	1.449	4,90	1.514	5,80						
27.540	1.419	4,21	1.483	5,17								
28.440	1.454	4,51	1.517	5,45								

Unit with High Static Pressure (Option 151)

Air Flow Rate (m³/h)	Unit External Static Pressure (Pa)																			
	50		150		250		350		450		550		650		750		850		950	
	rpm	kW	rpm	kW	rpm	kW	rpm	kW	rpm	kW	rpm	kW	rpm	kW	rpm	kW	rpm	kW	rpm	kW
18.540	1.085	2,31	1.172	3,02	1.257	3,68	1.337	4,40	1.412	5,19	1.483	5,90	1.550	6,75	1.614	7,56	1.676	8,40	1.737	9,26
19.440	1.116	2,45	1.199	3,20	1.281	3,85	1.361	4,63	1.435	5,43	1.504	6,22	1.571	7,06	1.634	7,86	1.696	8,76	1.755	9,64
20.340	1.147	2,63	1.228	3,37	1.307	4,03	1.385	4,87	1.459	5,66	1.526	6,53	1.593	7,37	1.656	8,20	1.716	9,12		
21.240	1.179	2,81	1.257	3,53	1.333	4,29	1.410	5,11	1.483	5,89	1.550	6,82	1.614	7,68	1.677	8,57	1.738	9,48		
22.140	1.211	2,99	1.287	3,69	1.360	4,54	1.435	5,35	1.507	6,19	1.574	7,11	1.637	7,98	1.699	8,95	1.759	9,85		
23.040	1.243	3,17	1.317	3,87	1.390	4,77	1.461	5,60	1.531	6,49	1.598	7,40	1.661	8,33	1.722	9,33				
23.940	1.275	3,35	1.349	4,12	1.419	5,00	1.488	5,86	1.556	6,79	1.622	7,69	1.685	8,68	1.746	9,67				
24.840	1.308	3,54	1.380	4,37	1.449	5,24	1.516	6,17	1.582	7,10	1.647	8,00	1.709	9,02	1.769	10,01				
25.740	1.341	3,76	1.412	4,62	1.480	5,47	1.545	6,45	1.608	7,42	1.672	8,36	1.734	9,37						
26.640	1.375	4,01	1.444	4,87	1.510	5,74	1.574	6,75	1.635	7,73	1.698	8,74	1.759	9,73						
27.540	1.408	4,24	1.475	5,11	1.541	6,04	1.603	7,03	1.663	8,04	1.724	9,12								
28.440	1.442	4,49	1.507	5,36	1.572	6,35	1.634	7,32	1.693	8,39	1.752	9,52								

### 7.13 Supply Fan Performance, 50/48 UC-(V)/UP-(V) 190UP-(V) 190

Unit with Standard Static Pressure

Air Flow Rate (m³/h)	Unit External Static Pressure (Pa)											
	50		150		250		350		450		550	
	rpm	kW	rpm	kW	rpm	kW	rpm	kW	rpm	kW	rpm	kW
23.760	1.001	2877	1.095	3816	1.181	4791	1.261	5757	1.335	6804	1.405	7821
25.200	1.033	3162	1.123	4107	1.207	5085	1.286	6132	1.359	7173	1.428	8298
26.640	1.066	3366	1.152	4410	1.234	5367	1.311	6516	1.383	7551	1.452	8760
28.080	1.099	3645	1.181	4710	1.261	5730	1.336	6873	1.407	8013	1.475	9213
29.520	1.133	3954	1.212	5004	1.289	6105	1.362	7230	1.432	8490	1.500	9684
30.960	1.167	4251	1.243	5280	1.316	6474	1.388	7587	1.458	8916	1.524	10152
32.400	1.202	4560	1.275	5646	1.345	6840	1.415	8046	1.484	9351		
33.840	1.237	4839	1.307	6006	1.375	7173	1.443	8508	1.510	9780		
35.280	1.272	5166	1.340	6375	1.406	7566	1.472	8967				
36.720	1.307	5529	1.372	6750	1.438	8022	1.501	9384				
38.160	1.342	5895	1.406	7140	1.470	8484	1.532	9810				
39.600	1.379	6264	1.441	7611	1.503	8958						

Unit with High Static Pressure (Option 151)

Air Flow Rate (m³/h)	Unit External Static Pressure (Pa)																			
	50		150		250		350		450		550		650		750		850		950	
	rpm	kW	rpm	kW	rpm	kW	rpm	kW	rpm	kW	rpm	kW	rpm	kW	rpm	kW	rpm	kW	rpm	kW
23.760	1.000	3090	1.094	3930	1.179	4947	1.259	5856	1.333	6819	1.403	7926	1.471	8940	1.536	10101	1.598	11265	1.658	12399
25.200	1.031	3333	1.121	4206	1.205	5235	1.283	6177	1.357	7248	1.426	8337	1.492	9402	1.556	10617	1.617	11775	1.677	12981
26.640	1.063	3540	1.149	4518	1.232	5526	1.309	6495	1.381	7683	1.449	8763	1.514	9915	1.577	11151	1.637	12297	1.696	13590
28.080	1.096	3741	1.177	4827	1.257	5811	1.334	6885	1.405	8100	1.472	9186	1.537	10425	1.598	11649	1.657	12882	1.716	14205
29.520	1.129	4011	1.207	5142	1.284	6111	1.360	7290	1.430	8499	1.496	9684	1.560	10962	1.621	12171	1.680	13491	1.736	14841
30.960	1.162	4308	1.237	5412	1.311	6435	1.386	7689	1.456	8886	1.521	10182	1.583	11487	1.644	12708	1.702	14097	1.758	15435
32.400	1.196	4620	1.269	5694	1.340	6888	1.413	8106	1.482	9288	1.547	10683	1.608	12012	1.668	13347	1.725	14727		
33.840	1.230	4923	1.301	5970	1.371	7287	1.440	8526	1.508	9780	1.572	11172	1.633	12495	1.691	13983	1.749	15357		
35.280	1.264	5226	1.334	6339	1.402	7674	1.468	8952	1.534	10290	1.598	11664	1.658	13053	1.716	14562				
36.720	1.299	5532	1.368	6759	1.434	8064	1.497	9399	1.561	10812	1.624	12159	1.684	13638	1.742	15135				
38.160	1.333	5880	1.401	7176	1.466	8457	1.528	9882	1.589	11340	1.650	12693	1.710	14226	1.767	15711				
39.600	1.369	6297	1.435	7593	1.499	8856	1.559	10374	1.618	11865	1.678	13320	1.736	14826						

### 7.14 Supply Fan Performance, 50/48 UC-(V)/UP-(V) 220

Unit with Standard Static Pressure

Air Flow Rate (m <sup>3</sup> /h)	Unit External Static Pressure (Pa)											
	50		150		250		350		450		550	
	rpm	kW	rpm	kW	rpm	kW	rpm	kW	rpm	kW	rpm	kW
23.760	1.001	2877	1.095	3816	1.181	4791	1.261	5757	1.335	6804	1.405	7821
25.200	1.033	3162	1.123	4107	1.207	5085	1.286	6132	1.359	7173	1.428	8298
26.640	1.066	3366	1.152	4410	1.234	5367	1.311	6516	1.383	7551	1.452	8760
28.080	1.099	3645	1.181	4710	1.261	5730	1.336	6873	1.407	8013	1.475	9213
29.520	1.133	3954	1.212	5004	1.289	6105	1.362	7230	1.432	8490	1.500	9684
30.960	1.167	4251	1.243	5280	1.316	6474	1.388	7587	1.458	8916	1.524	10152
32.400	1.202	4560	1.275	5646	1.345	6840	1.415	8046	1.484	9351		
33.840	1.237	4839	1.307	6006	1.375	7173	1.443	8508	1.510	9780		
35.280	1.272	5166	1.340	6375	1.406	7566	1.472	8967				
36.720	1.307	5529	1.372	6750	1.438	8022	1.501	9384				
38.160	1.342	5895	1.406	7140	1.470	8484	1.532	9810				
39.600	1.379	6264	1.441	7611	1.503	8958						

Unit with High Static Pressure (Option 151)

Air Flow Rate (m <sup>3</sup> /h)	Unit External Static Pressure (Pa)																			
	50		150		250		350		450		550		650		750		850		950	
	rpm	kW	rpm	kW	rpm	kW	rpm	kW	rpm	kW	rpm	kW	rpm	kW	rpm	kW	rpm	kW	rpm	kW
23.760	1.000	3090	1.094	3930	1.179	4947	1.259	5856	1.333	6819	1.403	7926	1.471	8940	1.536	10101	1.598	11265	1.658	12399
25.200	1.031	3333	1.121	4206	1.205	5235	1.283	6177	1.357	7248	1.426	8337	1.492	9402	1.556	10617	1.617	11775	1.677	12981
26.640	1.063	3540	1.149	4518	1.232	5526	1.309	6495	1.381	7683	1.449	8763	1.514	9915	1.577	11151	1.637	12297	1.696	13590
28.080	1.096	3741	1.177	4827	1.257	5811	1.334	6885	1.405	8100	1.472	9186	1.537	10425	1.598	11649	1.657	12882	1.716	14205
29.520	1.129	4011	1.207	5142	1.284	6111	1.360	7290	1.430	8499	1.496	9684	1.560	10962	1.621	12171	1.680	13491	1.736	14841
30.960	1.162	4308	1.237	5412	1.311	6435	1.386	7689	1.456	8886	1.521	10182	1.583	11487	1.644	12708	1.702	14097	1.758	15435
32.400	1.196	4620	1.269	5694	1.340	6888	1.413	8106	1.482	9288	1.547	10683	1.608	12012	1.668	13347	1.725	14727		
33.840	1.230	4923	1.301	5970	1.371	7287	1.440	8526	1.508	9780	1.572	11172	1.633	12495	1.691	13983	1.749	15357		
35.280	1.264	5226	1.334	6339	1.402	7674	1.468	8952	1.534	10290	1.598	11664	1.658	13053	1.716	14562				
36.720	1.299	5532	1.368	6759	1.434	8064	1.497	9399	1.561	10812	1.624	12159	1.684	13638	1.742	15135				
38.160	1.333	5880	1.401	7176	1.466	8457	1.528	9882	1.589	11340	1.650	12693	1.710	14226	1.767	15711				
39.600	1.369	6297	1.435	7593	1.499	8856	1.559	10374	1.618	11865	1.678	13320	1.736	14826						

## 7.15 - Pressure Drops (Pa)

### 50/48 UC-(V)/UP-(V) 025 & 035

Option No	Option Name	Unit Air Flow Rate (m <sup>3</sup> /h)									
		2.880	3.420	3.960	4.500	5.040	5.580	6.120	6.660	7.200	7.740
122	Electric Heater	19	23	26	30	33	37	40	44	48	51
123	Electric Heater	19	23	26	30	33	37	40	44	48	51
125	Hot Water Coil	4	5	6	7	8	9	10	12	13	14
126	Natural Gas Heater	37	49	62	76	92	108	127	146	167	189
127	Natural Gas Heater	23	35	48	61	74	88	102	117	133	149
141	Manual Outdoor Air Damper	3	3	4	5	6	7	8	9	10	12
142, 143, 144, 145	Economizer	3	3	4	5	6	7	8	9	10	12
146, 148	Economizer + Pre-Heater_Low	44	52	60	69	78	87	96	105	114	125
147, 149	Economizer + Pre-Heater_High	44	52	60	69	78	87	96	105	114	125
161	ISO Coarse 65% Filter (G4 Filter)	2	2	3	3	4	4	5	5	5	5
162	ISO ePM1 55% Filter (F7 Filter)	13	16	19	22	25	28	31	34	38	41
163	ISO Coarse 65% + ISO ePM1 55% Filter (G4 + F7 Filter)	30	36	42	49	56	63	70	77	85	92
164	ISO ePM10 75% + ISO ePM1 55% Filter (M6 + F7 Filter)	38	47	56	65	74	84	94	104	114	125
165	ISO ePM1 55% + ISO ePM1 80% Filter (F7 + F9 Filter)	66	80	95	111	127	143	160	177	195	213
175	Thermodynamic HR	4	6	7	8	9	11	12	14	15	16
Option No	Option Name	Fresh Air Flow Rate (m <sup>3</sup> /h)									
		1.080	1.800	2.520	3.240	3.960	4.680	5.400	6.120	6.840	7.740
172, 174, 176, 177	ERM 3.0-5.0-7.0 E/S Fresh Air Filter	12	20	30	40	51	62	75	88	102	117
172	Rotary HR ERM 3.0 E	59	102	146	192	240	291	343	N/A	N/A	N/A
172, 176	Rotary HR ERM 5.0 E	36	61	86	112	139	167	196	225	255	294
176	Rotary HR ERM 7.0 E	28	46	66	86	106	127	148	170	192	220
174	Rotary HR ERM 3.0 S	62	106	153	201	252	304	359	N/A	N/A	N/A
174, 177	Rotary HR ERM 5.0 S	37	63	90	118	146	175	205	236	267	308
177	Rotary HR ERM 7.0 S	29	49	69	90	111	133	155	178	201	230
Option No	Option Name	Exhaust Air Flow Rate (m <sup>3</sup> /h)									
		1.080	1.800	2.520	3.240	3.960	4.680	5.400	6.120	6.840	7.740
172	Rotary HR ERM 3.0 E	59	102	146	192	240	291	343	N/A	N/A	N/A
172, 176	Rotary HR ERM 5.0 E	36	61	86	112	139	167	196	225	255	294
176	Rotary HR ERM 7.0 E	28	46	66	86	106	127	148	170	192	220
174	Rotary HR ERM 3.0 S	62	106	153	201	252	304	359	N/A	N/A	N/A
174, 177	Rotary HR ERM 5.0 S	37	63	90	118	146	175	205	236	267	308
177	Rotary HR ERM 7.0 S	29	49	69	90	111	133	155	178	201	230
175	Thermodynamic HR	5	10	15	21	29	39	50	62	76	90

### 50/48 UC-(V)/UP-(V) 045 & 055

Option No	Option Name	Unit Air Flow Rate (m <sup>3</sup> /h)									
		5.400	6.120	6.840	7.560	8.280	9.000	9.720	10.440	11.160	11.880
121	Electric Heater	28	32	35	39	43	47	50	54	58	62
122	Electric Heater	28	32	35	39	43	47	50	54	58	62
123	Electric Heater	28	32	35	39	43	47	50	54	58	62
125	Hot Water Coil	7	8	9	10	11	13	14	16	17	19
126	Natural Gas Heater	50	63	77	92	108	124	142	161	181	202
127	Natural Gas Heater	41	50	61	72	84	98	111	126	142	158
141	Manual Outdoor Air Damper	5	6	7	8	10	12	13	15	18	20
142, 143, 144, 145	Economizer	5	6	7	8	10	12	13	15	18	20
146, 148	Economizer + Pre-Heater_Low	68	78	87	97	108	119	129	140	152	163
147, 149	Economizer + Pre-Heater_High	68	78	87	97	108	119	129	140	152	163
161	ISO Coarse 65% Filter (G4 Filter)	3	4	4	4	5	5	5	5	5	5
162	ISO ePM1 55% Filter (F7 Filter)	22	26	29	33	37	40	44	47	51	55
163	ISO Coarse 65% + ISO ePM1 55% Filter (G4 + F7 Filter)	50	58	66	74	82	91	99	108	117	126
164	ISO ePM10 75% + ISO ePM1 55% Filter (M6 + F7 Filter)	66	77	88	99	111	122	134	147	159	171
165	ISO ePM1 55% + ISO ePM1 80% Filter (F7 + F9 Filter)	113	131	150	169	189	209	229	250	271	292
175	Thermodynamic HR	7	8	9	10	12	13	14	15	16	18
Option No	Option Name	Fresh Air Flow Rate (m <sup>3</sup> /h)									
		2.160	3.240	4.320	5.400	6.480	7.560	8.640	9.720	10.800	11.880
172, 174, 176, 177	ERM 7.1 E/S Fresh Air Filter	19	30	42	55	69	84	100	118	137	157
172, 174, 176, 177	ERM 9.2-11.2 E/S Fresh Air Filter	17	27	37	48	61	74	88	103	119	136
172	Rotary HR ERM 7.1 E	56	86	116	148	181	214	249	285	321	359
172, 176	Rotary HR ERM 9.2 E	44	68	91	116	141	167	193	220	248	276
176	Rotary HR ERM 11.2 E	36	55	74	93	113	134	154	176	197	219
174	Rotary HR ERM 7.1 S	59	90	112	155	189	224	261	298	337	N/A
174, 177	Rotary HR ERM 9.2 S	46	71	96	121	148	175	202	231	260	289
177	Rotary HR ERM 11.2 S	38	57	77	98	119	146	162	184	207	230
Option No	Option Name	Exhaust Air Flow Rate (m <sup>3</sup> /h)									
		2.160	3.240	4.320	5.400	6.480	7.560	8.640	9.720	10.800	11.880
172	Rotary HR ERM 7.1 E	56	86	116	148	181	214	249	285	321	359
172, 176	Rotary HR ERM 9.2 E	44	68	91	116	141	167	193	220	248	276
176	Rotary HR ERM 11.2 E	36	55	74	93	113	134	154	176	197	219
174	Rotary HR ERM 7.1 S	59	90	112	155	189	224	261	298	337	N/A
174, 177	Rotary HR ERM 9.2 S	46	71	96	121	148	175	202	231	260	289
177	Rotary HR ERM 11.2 S	38	57	77	98	119	146	162	184	207	230
175	Thermodynamic HR	11	19	29	43	59	77	97	119	144	170

50/48 UC-(V)/UP-(V) 065 & 075 & 090 & 105

Option No	Option Description	Unit Air Flow Rate (m <sup>3</sup> /h)									
		7,740	8,820	9,900	10,980	12,060	13,140	14,220	15,300	16,380	17,460
121	Electric Heater	23	26	29	32	35	38	41	45	48	51
122	Electric Heater	23	26	29	32	35	38	41	45	48	51
123	Electric Heater	23	26	29	32	35	38	41	45	48	51
125	Hot Water Coil	7	8	9	10	12	13	15	16	18	20
126	Natural Gas Heater	42	53	65	78	92	108	124	142	161	182
127	Natural Gas Heater	38	47	57	68	79	92	105	120	135	151
128	Natural Gas Heater	37	45	54	64	74	85	97	109	122	136
141	Manual Outdoor Air Damper	3	4	4	5	6	6	7	8	9	10
142, 143, 144, 145	Economizer	3	4	4	5	6	6	7	8	9	10
146, 148	Economizer + Pre-Heater Low	50	57	64	72	80	86	94	102	110	118
147, 149	Economizer + Pre-Heater High	50	57	64	72	80	86	94	102	110	118
161	ISO Coarse 65% Filter (G4 Filter)	3	3	4	4	4	5	5	5	5	5
162	ISO ePM1 55% Filter (F7 Filter)	19	22	25	29	32	35	39	42	45	49
163	ISO Coarse 65% + ISO ePM1 55% Filter (G4 + F7 Filter)	43	50	57	64	72	79	87	95	103	111
164	ISO ePM10 75% + ISO ePM1 55% Filter (M6 + F7 Filter)	56	66	76	86	96	107	117	128	139	151
165	ISO ePM1 55% + ISO ePM1 80% Filter (F7 + F9 Filter)	97	113	130	147	164	182	200	219	238	257
175	Thermodynamic HR	6	6	7	7	8	9	10	11	11	12
Option No	Option Description	Fresh Air Flow Rate (m <sup>3</sup> /h)									
		2,232	3,924	5,616	7,308	9,000	10,692	12,384	14,076	15,768	17,460
172, 174, 176, 177	ERM 11.4-13.4-17.4 E/S Fresh Air Filter	10	19	29	40	52	66	83	101	123	147
172	Rotary HR ERM 11.4 E	37	67	97	129	161	195	230	266	302	340
172, 176	Rotary HR ERM 13.4 E	31	55	80	106	132	159	187	216	245	275
176	Rotary HR ERM 17.4 E	24	42	61	80	99	120	140	161	182	204
174	Rotary HR ERM 11.4 S	39	70	102	135	169	204	241	278	317	356
174, 177	Rotary HR ERM 13.4 S	32	58	84	111	138	167	196	226	257	288
177	Rotary HR ERM 17.4 S	25	44	64	84	104	125	147	169	191	214
Option No	Option Description	Exhaust Air Flow Rate (m <sup>3</sup> /h)									
		2,232	3,924	5,616	7,308	9,000	10,692	12,384	14,076	15,768	17,460
172	Rotary HR ERM 11.4 E	37	67	97	129	161	195	230	266	302	340
172, 176	Rotary HR ERM 13.4 E	31	55	80	106	132	159	187	216	245	275
176	Rotary HR ERM 17.4 E	24	42	61	80	99	120	140	161	182	204
174	Rotary HR ERM 11.4 S	39	70	102	135	169	204	241	278	317	356
174, 177	Rotary HR ERM 13.4 S	32	58	84	111	138	167	196	226	257	288
177	Rotary HR ERM 17.4 S	25	44	64	84	104	125	147	169	191	214
175	Thermodynamic HR	6	12	19	25	35	47	61	76	93	111

50/48 UC-(V)/UP-(V) 125 & 140

Option No	Option Description	Unit Air Flow Rate (m <sup>3</sup> /h)									
		12,240	13,680	15,120	16,560	18,000	19,440	20,880	22,320	23,760	25,200
121	Electric Heater	50	56	62	68	74	80	86	92	98	105
122	Electric Heater	50	56	62	68	74	80	86	92	98	105
123	Electric Heater	50	56	62	68	74	80	86	92	98	105
124	Hot Water Coil	19	23	28	33	38	43	48	54	60	67
125	Hot Water Coil	35	42	50	59	68	77	87	98	109	121
126	Natural Gas Heater	41	49	59	69	80	92	104	118	132	147
127	Natural Gas Heater	41	52	64	77	91	106	123	140	159	180
128	Natural Gas Heater	42	52	63	76	90	105	121	138	157	176
141	Manual Outdoor Air Damper	5	6	7	8	10	11	13	14	16	18
142, 143, 144, 145	Economizer	5	6	7	8	10	11	13	15	17	19
146, 148	Economizer + Pre-Heater Low	70	79	88	97	107	116	126	136	146	156
147, 149	Economizer + Pre-Heater High	70	79	88	97	107	116	126	136	146	156
161	ISO Coarse 65% Filter (G4 Filter)	4	22	24	27	29	32	35	38	40	43
162	ISO ePM1 55% Filter (F7 Filter)	30	54	61	68	75	82	90	97	105	113
163	ISO Coarse 65% + ISO ePM1 55% Filter (G4 + F7 Filter)	68	101	113	126	140	154	168	183	198	214
164	ISO ePM10 75% + ISO ePM1 55% Filter (M6 + F7 Filter)	91	129	146	163	181	199	217	236	256	276
165	ISO ePM1 55% + ISO ePM1 80% Filter (F7 + F9 Filter)	100	141	159	178	198	218	239	261	283	306
175	Thermodynamic HR	8	10	11	12	13	15	16	18	20	22
Option No	Option Description	Fresh Air Flow Rate (m <sup>3</sup> /h)									
		2,160	5,040	7,920	10,800	13,680	16,560	19,440	22,320	25,200	
172, 174	ERM 17.4 E/S Fresh Air Filter	10	25	44	67	97	134	181	239	310	
176, 177	ERM 23.5-28.6 E/S Fresh Air Filter	6	15	25	36	49	64	81	102	125	
172	Rotary HR ERM 17.4 E	23	54	87	121	156	192	230	269	N/A	
176	Rotary HR ERM 23.5 E	17	40	64	88	113	139	165	192	220	
176	Rotary HR ERM 28.6 E	14	34	54	74	95	117	139	162	185	
174	Rotary HR ERM 17.4 S	24	57	91	127	163	202	241	282	N/A	
177	Rotary HR ERM 23.5 S	18	42	67	92	118	145	173	202	231	
177	Rotary HR ERM 28.6 S	15	35	56	78	100	123	146	169	193	
Option No	Option Description	Exhaust Air Flow Rate (m <sup>3</sup> /h)									
		2,160	5,040	7,920	10,800	13,680	16,560	19,440	22,320	25,200	
172	Rotary HR ERM 17.4 E	23	54	87	121	156	192	230	269	N/A	
176	Rotary HR ERM 23.5 E	17	40	64	88	113	139	165	192	220	
176	Rotary HR ERM 28.6 E	14	34	54	74	95	117	139	162	185	
174	Rotary HR ERM 17.4 S	24	57	91	127	163	202	241	282	N/A	
177	Rotary HR ERM 23.5 S	18	42	67	92	118	145	173	202	231	
177	Rotary HR ERM 28.6 S	15	35	56	78	100	123	146	169	193	
175	Thermodynamic HR	6	16	29	47	71	99	131	166	205	

50/48 UC-(V)/UP-(V) 160

Option No	Option Description	Unit Air Flow Rate (m <sup>3</sup> /h)									
		13,680	15,120	16,560	18,000	19,440	20,880	22,320	23,760	25,200	28,080
121	Electric Heater	56	62	68	74	80	86	92	98	105	117
122	Electric Heater	56	62	68	74	80	86	92	98	105	117
123	Electric Heater	56	62	68	74	80	86	92	98	105	117
125	Hot Water Coil	23	28	33	38	43	48	54	60	67	81
125	Hot Water Coil	42	50	59	68	77	87	98	109	121	145
126	Natural Gas Heater	49	59	69	80	92	104	118	132	147	180
127	Natural Gas Heater	42	52	63	75	88	102	117	133	150	187
128	Natural Gas Heater	42	52	62	74	86	99	113	129	145	180
141	Manual Outdoor Air Damper	6	7	8	10	11	13	14	16	18	22
142, 143, 144, 145	Economizer	6	7	8	10	11	13	15	17	19	23
146, 148	Economizer + Pre-Heater Low	79	88	97	107	116	126	136	146	156	177
147, 149	Economizer + Pre-Heater High	79	88	97	107	116	126	136	146	156	177
161	ISO Coarse 65% Filter (G4 Filter)	22	24	27	29	32	35	38	40	43	51
162	ISO ePM1 55% Filter (F7 Filter)	54	61	68	75	82	90	97	105	113	125
163	ISO Coarse 65% + ISO ePM1 55% Filter (G4 + F7 Filter)	101	113	126	140	154	168	183	198	214	232
164	ISO ePM10 75% + ISO ePM1 55% Filter (M6 + F7 Filter)	129	146	163	181	199	217	236	256	276	298
165	ISO ePM1 55% + ISO ePM1 80% Filter (F7 + F9 Filter)	141	159	178	198	218	239	261	283	306	331
175	Thermodynamic HR	10	11	12	13	15	16	18	20	22	26
Option No	Option Description	Fresh Air Flow Rate (m <sup>3</sup> /h)									
		2,160	5,040	7,920	10,800	13,680	16,560	19,440	22,320	25,200	28,080
172, 174, 176, 177	ERM 23.5-28.6 E/S Fresh Air Filter	6	15	25	36	49	64	81	102	125	152
172	Rotary HR ERM 23.5 E	17	40	64	88	113	139	165	192	220	249
176	Rotary HR ERM 28.6 E	14	34	54	74	95	117	139	162	185	208
174	Rotary HR ERM 23.5 S	18	42	67	92	118	145	173	202	231	261
177	Rotary HR ERM 28.6 S	15	35	56	78	100	123	146	169	193	218
Option No	Option Description	Exhaust Air Flow Rate (m <sup>3</sup> /h)									
		2,160	5,040	7,920	10,800	13,680	16,560	19,440	22,320	25,200	28,080
172	Rotary HR ERM 23.5 E	17	40	64	88	113	139	165	192	220	249
176	Rotary HR ERM 28.6 E	14	34	54	74	95	117	139	162	185	208
174	Rotary HR ERM 23.5 S	18	42	67	92	118	145	173	202	231	261
177	Rotary HR ERM 28.6 S	15	35	56	78	100	123	146	169	193	218
175	Thermodynamic HR	6	16	29	47	71	99	131	166	205	248

50/48 UC-(V)/UP-(V) 190 & 220

Option No	Option Description	Unit Air Flow Rate (m <sup>3</sup> /h)									
		23,760	25,200	26,640	28,080	29,520	31,176	35,640	37,260	38,880	40,500
121	Electric Heater	65	69	73	77	81	86	99	103	108	112
122	Electric Heater	65	69	73	77	81	86	99	103	108	112
123	Electric Heater	65	69	73	77	81	86	99	103	108	112
125	Hot Water Coil	32	35	39	43	47	51	65	70	75	81
125	Hot Water Coil	60	66	73	80	87	95	118	126	135	143
127	Natural Gas Heater	72	79	88	96	104	114	123	134	145	150
128	Natural Gas Heater	80	90	100	110	117	130	140	150	160	166
141	Manual Outdoor Air Damper	6	7	7	8	9	10	13	14	15	16
142, 143, 144, 145	Economizer	6	7	7	8	9	10	13	14	15	16
146, 148	Economizer + Pre-Heater Low	146	156	166	176	186	197	228	239	250	261
147, 149	Economizer + Pre-Heater High	146	156	166	176	186	197	228	239	250	261
161	ISO Coarse 65% Filter (G4 Filter)	4	4	5	5	5	5	5	5	5	5
162	ISO ePM1 55% Filter (F7 Filter)	30	32	34	36	39	41	48	50	52	55
163	ISO Coarse 65% + ISO ePM1 55% Filter (G4 + F7 Filter)	67	72	77	82	87	93	109	114	120	126
164	ISO ePM10 75% + ISO ePM1 55% Filter (M6 + F7 Filter)	90	97	103	110	117	125	147	155	163	171
165	ISO ePM1 55% + ISO ePM1 80% Filter (F7 + F9 Filter)	154	165	176	188	200	213	251	264	278	292
Option No	Option Description	Fresh Air Flow Rate (m <sup>3</sup> /h)									
		6,480	12,240	17,280	20,880	24,480	28,080	31,680	35,280	38,880	40,500
172, 174, 176, 177	ERM 29.6 E/S Fresh Air Filter	18	39	62	82	106	134	167			
172, 174, 176, 177	ERM 40.7 E/S Fresh Air Filter	12	25	38	49	61	74	89	106	125	135
172	Rotary HR ERM 29.6 E	28	54	79	98	117	137	157			
176	Rotary HR ERM 40.7 E	20	38	55	68	81	94	107	121	135	142
174	Rotary HR ERM 29.6 S	29	57	83	102	122	143	165			
177	Rotary HR ERM 40.7 S	21	40	58	71	84	98	112	127	142	149
Option No	Option Description	Exhaust Air Flow Rate (m <sup>3</sup> /h)									
		6,480	12,240	17,280	20,880	24,480	28,080	31,680	35,280	38,880	40,500
172	Rotary HR ERM 29.6 E	28	54	79	98	117	137	157			
176	Rotary HR ERM 40.7 E	20	38	55	68	81	94	107	121	135	142
174	Rotary HR ERM 29.6 S	29	57	83	102	122	143	165			
177	Rotary HR ERM 40.7 S	21	40	58	71	84	98	112	127	142	149



### 7.16 - Air Flow Rate Limits

Model	Air Flow Rate (m <sup>3</sup> /h)	
	Min	Max
025	3.364	5.046
035	4.709	7.063
045	6.054	9.082
055	7.400	11.100
065	8.370	12.556
075	9.226	13.840
090	10.000	15.000
105	11.600	17.400
125	15.500	23.250
140	16.783	25.175
160	18.618	27.928
190	24.480	36.720
220	26.266	39.398

### 7.17 - Indoor Fan Air Flow Rate Adjustment

The indoor fan is an EC Plug fan, sliding on rails, equipped with a differential pressure measurement sensor between in front of the inlet ring and the inlet ring at the narrowest point. (See Fig.7)

It is possible to set the air flow through the SmartVu control. For a detailed explanation please refer to the SmartVu Control IOM.

**WARNING:** Before opening the doors, switch off and deenergize the fan and allow it to run down (minimum two minutes).

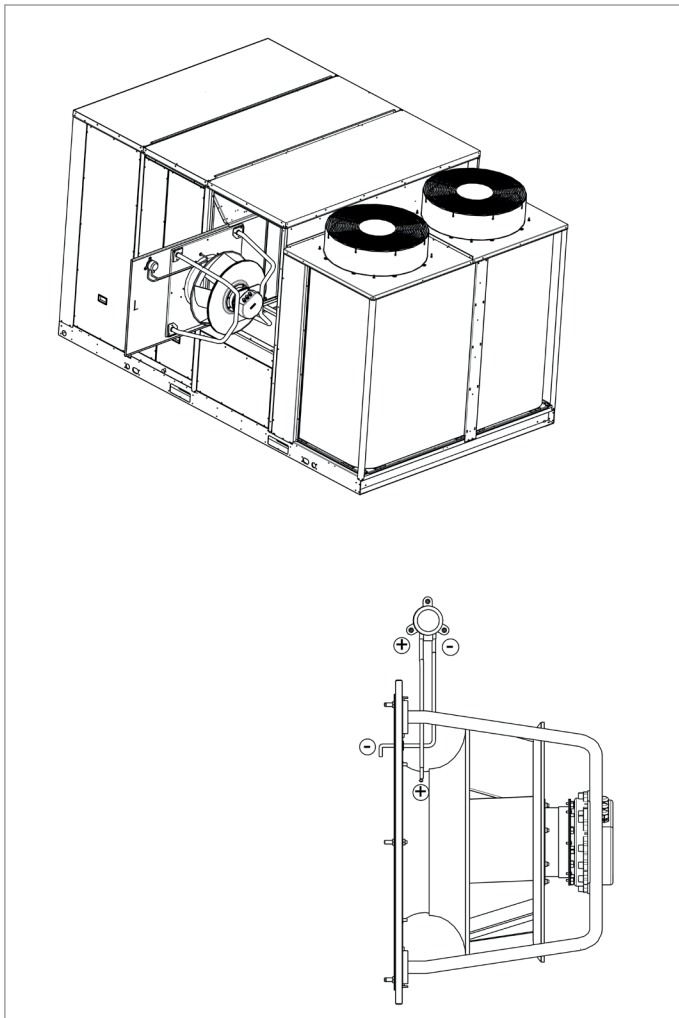

Fig. 7 – EC plug fan

## 8 - ELECTRICAL CONNECTIONS

**WARNING:** To prevent electrical shock or equipment damage, make sure disconnects are open before electrical connections are made. If this action is not taken, personal injury may occur.

Field wiring must comply with all applicable codes. Take special care when making the earth connection with the main earth bar inside the control box.

### 8.1 - Control Box

Please refer to the certified dimensional drawings supplied with the unit.

### 8.2 - Power Supply

The power supply must conform to the specification on the unit nameplate. The supply voltage must be within the range given in the electrical data table. For connections refer to the wiring diagrams and the certified dimensional drawings

**WARNING:** Operation of the unit with an improper supply voltage or excessive phase imbalance constitutes abuse which will invalidate the Carrier warranty. If the phase imbalance exceeds 2% for voltage, or 10% for current, contact your local electricity supply at once and ensure that the unit is not switched on until corrective measures have been taken.

### 8.3 - Voltage Phase Imbalance (%)

Example:

Nominal supply: 400-3-50

AB = 404 V

BC = 399 V

AC = 394 V

Average voltage =  $\frac{404 + 399 + 394}{3} = 399 = 400 \text{ V}$

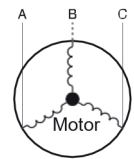

Determine maximum deviation from average voltage:

AB = 404 - 400 = 4

BC = 400 - 399 = 1

AC = 400 - 394 = 6

Largest deviation is 6 volts. Percentage voltage imbalance is therefore:

$\frac{6}{400} \times 100 = 1.5\%$

## 8.4 - Recommended Wire Sections

Wire sizing is the responsibility of the installer, and depends on the characteristics and regulations applicable to each installation site. The following is only to be used as a guideline, and does not make Carrier in any way liable. After wire sizing has been completed, using the certified dimensional drawing, the installer must ensure easy connection and define any modifications necessary on site. The connections provided as standard for the field-supplied power entry cables to the general disconnect/isolator switch are designed for the number and type of wires, listed in the table below.

The calculations are based on the maximum machine current (see electrical data tables) and the standard installation practices in accordance with IEC 60364, table 52C.

- The calculation is based on PVC Cu.
- A maximum ambient temperature of 46°C has been taken into consideration.

**IMPORTANT:** Main power cables (L1 - L2 - L3) on the main switch block can be connected without phase order check. If the phase order is wrong, SmartVu will not operate the unit. Order of 3 phases should be changed until the unit starts to operate.

**WARNING:** Phase order relay is used as standard equipment in the electrical panel. Even if the unit doesn't operate due to phase order error, electricity is still on in the panel

- The given wire length limits the voltage drop to < 5% (length L in meters - see table below).

Maximum Input Current	Minimum Cable Size by Phase	Cable Type	Maximum Cable Length
A	mm <sup>2</sup>		m
36	1 x 6	PVC-Cu	65
50	1 x 10	PVC-Cu	80
66	1 x 16	PVC-Cu	95
84	1 x 25	PVC-Cu	115
104	1 x 35	PVC-Cu	130
123	1 x 50	PVC-Cu	160
155	1 x 70	PVC-Cu	175
192	1 x 95	PVC-Cu	195
235	1 x 120	PVC-Cu	160
285	1 x 150	PVC-Cu	175
350	1 x 185	PVC-Cu	195

## 8.5 - Power and Control Cable Entry

For the cable entry refer to the certified dimensional drawing for the unit.

## 8.6 - Field Control Wiring

Refer to the SmartVu Controls IOM and the certified wiring diagram supplied with the unit for the field control wiring of the following features:

- Remote on/off switch
- Demand limit external switch
- Remote setpoint
- Alarm, alert and operation report

## 8.7 - Power Supply

**ATTENTION:** After the unit has been commissioned, the power supply must only be disconnected for quick maintenance operations (one day maximum). For longer maintenance operations or when the unit is taken out of service the power supply must be maintained to ensure supply to the heaters (compressor oil crankcase heaters for unit frost protection).

After all possible options have been connected, the transformer ensures the availability of a usable 24 VA or 1 A power reserve for the control circuit on site.

## 9 - START-UP

### 9.1 - Preliminary Checks

Never be tempted to start the rooftop unit without reading fully, and understanding, the operating instructions and without having carried out the following pre-start checks:

- Ensure that all electrical connections are properly tightened.
- Ensure that the unit is level and well-supported.
- Check the condition of the ductwork in case damage has occurred during installation.
- The air filter should be clean and in place.
- All the panels should be fitted and firmly secured with the corresponding screws.
- Make sure that there is sufficient space for servicing and maintenance purposes
- Check the drain connections.
- Ensure that there are no refrigerant leaks.
- Confirm that the electrical power source agrees with the unit nameplate rating
- Make sure that compressors float freely on the rubber isolators

**WARNING:** The compressors are mounted on vibration isolators. Do not loosen or remove the support mounting bolts.

- Check if the phase rotation is in the right order for supply air fan, outdoor air fan and compressors.

## 9.2 - Actual Start-up

### IMPORTANT:

- Commissioning and start-up of the unit must be supervised by a qualified refrigeration engineer.
- Start-up and operating tests must be carried out with circulating through the indoor coil.
- All setpoint adjustments and control tests must be carried out before the unit is started up.
- Please refer to the SmartVu control manual.

The unit should be started up in Local ON mode.

Ensure that all safety devices are satisfied especially the high pressure switches.

Actual start-up should only be done under the supervision of a qualified refrigeration mechanic.

## 9.3 - Defrost Cycle

When the outdoor temperature is sufficiently low, and depending on the atmospheric humidity, the water condensing on the outdoor coil freezes and this impedes correct air flow and heat exchange rate. It is necessary to remove the ice by melting it. This will be done by changing over the reversing valve on the solenoid coil. This reverses the system cycle and injects hot gas into the outdoor heat exchanger.

Defrost will be completed when the outdoor coil reaches the defrost temperature setpoint or after a predetermined period of time from the start of the cycle.

## 10 - MAJOR SYSTEM COMPONENTS

### 10.1 - Compressors

50/48 UC-(V)/UP-(V) units use hermetic scroll compressors.

Single circuit units use variable speed compressor and a variable frequency driver (VFD) as standard.

Each compressor is equipped with a crankcase oil heater, as standard for all units.

Compressors are fixed only for transportation. Fixing parts must be removed when unit installation is completed.”

Each compressor sub-function is equipped with:

- Anti-vibration mountings between the unit chassis and the chassis of the compressor sub-function.
- A single pressure safety switch at the discharge.

### 10.2 - Lubricant

The compressors installed in these units have a specific oil charge, indicated on the nameplate of each compressor.

The oil level check must be done with the unit switched off, when suction and discharge pressures are equalized.

The oil level must be visible and above the middle of the sight glass in the oil equalization line. If this is not the case, there is an oil leak in the circuit. Search and repair the leak, then recharge oil, so that it reaches a level between the middle and three quarters of the sight glass (unit in vacuum).

**ATTENTION:** Too much oil in the circuit can cause a unit defect. Please refer to the oil content in the physical data table.

**NOTE:** Use only oils which have been approved for the compressors. Never use oils which have been exposed to air.

**CAUTION:** R22 oils are absolutely not compatible with R410A or R454B oils and vice versa.

### 10.3 - Condensers/Evaporators

50/48 UC-(V)/UP-(V) coils are condensers/evaporators with internally grooved copper tubes with aluminum fins

To prevent ice formation at the bottom of the coils in 50/48 UP-(V) units, electric heaters are installed under the sheet metal base. They are switched on based on the outside temperature and during defrost cycle.

## 10.4 - Outdoor Fans

The fans are axial Flying Bird fans equipped with rotating shroud and made of composite recyclable material. The motors are three-phase, with permanently lubricated bearings and insulation class F. See tables below.

According to the Regulation No. 327/2011 implementing Directive 2009/125/EC with regard to ecodesign requirements for fans driven by motors with an electric input power between 125 W and 500 kW.

Product / Option	Unit	50/48 UC-(V)/UP-(V) 025-035-065	50/48 UC-(V)/UP-(V) 045-055-075-090-105-125-140-160-190-220
Global Fan Efficiency	%	37,8	39,4
Measurement Category		A	A
Efficiency Category		Static	Static
Energy Efficiency Target N (2015)		40	40
Efficiency Level at the Optimal Energy Efficiency Point		44,6	43,8
Variable Frequency Drive		No	No
Year of Manufacture		See Label on Unit	See Label on Unit
Fan Manufacturer		Simonin	Simonin
Motor Manufacturer		A.O. Smith / Regal Beloit	A.O. Smith / Regal Beloit
Fan Reference		00PSG002630700A	00PSG002630700A
Motor Reference		00PPG000464500A	00PPG000464600A
Nominal Input Motor	kW	0,85	2,02
Air Flow Rate	m <sup>3</sup> /s	3,75	4,25
Pressure	Pa	82	178
Speed	rpm	705	960
Specific Ratio		1,002	1,002
Product Disassembly, Recycling or Disposal at the End of its Life		See Service Manual	See Service Manual
Information About Minimising Environmental Impact		See Service Manual	See Service Manual

According to the Regulation No. 640/2009 and amendment 4/2014 implementing Directive 2005/32/EC with regard to ecodesign requirements for electric motors.

Product / Option	Unit	50/48 UC-(V)/UP-(V) 025-035-065	50/48 UC-(V)/UP-(V) 045-055-075-090-105-125-140-160-190-220
Motor Type		Dual Speed Asynchronous	Dual Speed Asynchronous
Number of Poles		8	6
Nominal Input Frequency	Hz	50	50
Nominal Voltage	V	400	400
Number of Phases		3	3
Motor included in the application domain of the regulation 640/2009 and amendment 4/2014		No	No
Sales Leaflet for Exemption		Article 2.1	Article 2.1
Ambient Air Temperature for Which the Motor is Specifically Designed	°C	68,5	68,5

## 10.5 - Indoor Fans

The fans are EC plug fan with integrated controller.

The motors are three-phase, with efficiency class IE4 and insulation class min. B.

## 10.6 - Electronic Expansion Valve (EXV)

The EXV is equipped with a stepper motor (2,625 + 160 /- 0 steps) that is controlled via the SIOB/CIOB board.

## 10.7 - Moisture Indicator

Located on the liquid line, the moisture indicator may be used to charge the unit and to indicate if there is moisture in the circuit. The presence of moisture changes the colour of the indicator paper in the sight glass.

## 10.8 - Filter Drier

This is a one-piece, brazed filter drier, located in the liquid line. The role of the filter drier is to keep the circuit clean and moisture-free. The moisture indicator shows when it is element is dirty.

## 10.9 - Refrigerant

50/48 UC-(V)/UP-(V) units operate with refrigerant R410A or R454B.

## 10.10 - Four-way Valve (50/48 UP-(V) Heat Pumps)

This permits reversal of the cycle for operation in cooling and heating mode and during defrost cycles.

## 10.11 - Sensors

The units use thermistors to measure the temperature, and pressure transducers to control and regulate system operation (see SmartVu IOM for a more detailed explanation).

## 10.12 - High Pressure Safety Switch

50/48 UC-(V)/UP-(V) units are equipped with automatically reset high pressure safety switches, calibrated to 4.420 kPa relative pressure for R410A and calibrated to 4.250 kPa relative pressure for R454B (unit alarm is manually reset)..

**WARNING:** Alteration of factory settings other than the design setpoint, without manufacturer's authorisation, may void the warranty.

### 10.13 - Variable Frequency Drive (VFD)

The VFD drives the variable speed compressor and it contains high voltage when connected to the rooftop unit main switch. Installation, start-up and maintenance should only be performed by qualified personnel. Failure to comply could result in death or serious injury.

### 10.14 - R-454B Refrigerant leak detector (standard)

Due to the A2L category of refrigerant R454B (lightly flammable), it requires the installation of a refrigerant leak detector. This detector uses infrared instead of semiconductor technology with no need of calibration (self-calibration), with very fast time response, and high lifetime (life cycle: 15 years).

This detector integrates, in a single assembly, housing + electronics + sensor. It is divided into two parts, for easy inspection and sensor replacement. Degree of protection: IP65

This detector is installed on a panel next to the supply fans of the indoor circuit. This position ensures the correct reading of the gas concentration in the indoor coil. If the sensor detects a high concentration of gas (adjustable) the unit enters the PROTECTION MODE. The electronic control instantly disables the compressors and support elements, activates the indoor fans (supply and also return if available) at 100% of airflow (adjustable) and opens the fresh and exhaust air dampers at 100% (if they are available). This happens temporarily, as long as the leak occurs or the sensor is held down with failure. If one of these two conditions ceases, the unit will return to the operating mode it had before the leak and the warning of protection mode will disappear.

In any case, alarms will be maintained until they are reset from the SmartVu control

### 11 - OPERATING LIMITS

These units have been designed to operate within the following limits (the pressure values are given as relative pressure):

Cooling Operation			Heat Pump Operation		
Zone	Air Temperature		Zone	Air Temperature	
	Dry Bulb	Wet Bulb		Dry Bulb	Wet Bulb
Indoor	Maximum	+35 °C	Indoor	Maximum	+27 °C
	Minimum	+18 °C		Minimum	+10 °C
Outdoor	Maximum	+52 °C*	Outdoor	Maximum	+22 °C
	Minimum	+10 °C		Minimum	-10 °C

Operating Mode	Minimum Outdoor Air Temperature
No compressor running & Free cooling mode	-20 °C
No compressor running & Electric heaters only mode	-20 °C
No compressor running & Hot water coil only mode	-20 °C
No compressor running & Gas burner only mode	-20 °C

\*+48°C for UCV/UPV 025, 035, 045, 055, 065, 075, 090, 105, 125, 140, 160, 190 and 220 sizes & +50°C for UC-/UP- 025, 035, 045, 055, 105, 125 and 140 sizes & +51°C for UC-/UP- 190 and 220

R410A Refrigerant	Unit	High Pressure	Low Pressure
Allowable Pressure (Min / Max)	kPa	-100 / 4.420	-11 / 3.100
Allowable Temperature (Min / Max)	°C	-20 / 68	-20 / 52
Pressure Switch Setting	kPa	4.420	
Unit Leak Test Pressure	kPa	3.410	

R454B Refrigerant	Unit	High Pressure	Low Pressure
Allowable Pressure (Min / Max)	kPa	-100 / 4.250	-11 / 3.100
Allowable Temperature (Min / Max)	°C	-20 / 68	-20 / 52
Pressure Switch Setting	kPa	4.250	
Unit Leak Test Pressure	kPa	3.410	

### 12 - GAS HEATING (48 UC-(V)/UP-(V) ONLY)

**IMPORTANT:** Inadequate installation, adjustment, information, servicing or maintenance can cause damage, injury to staff or loss of life.

Any unauthorized modifications or adjustments to the appliance are likely to invalidate the Certification, any warranty or guarantee and may also infringe on current statutory requirements.

Petrol, or other inflammable, fume-emitting products and liquids of any other application must not be stored or use in the vicinity of units.

After removing panels from the unit, keep them in a safe place to prevent them dropping from the roof

#### 12.1 - Introduction

The gas heating system is designed in accordance with the standards in force in compliance with the Gas Appliance regulation 2016/426/CE to be used inside the rooftop unit as an environment friendly alternative to the hot water coil or electric heating options. The gas heating located after the indoor fan. The standard location is at the bottom of the unit, for standard bottom supply (See Fig. 8a). It will be located at the top of the unit for supply or side supply via top plenum. (See Fig. 8b)

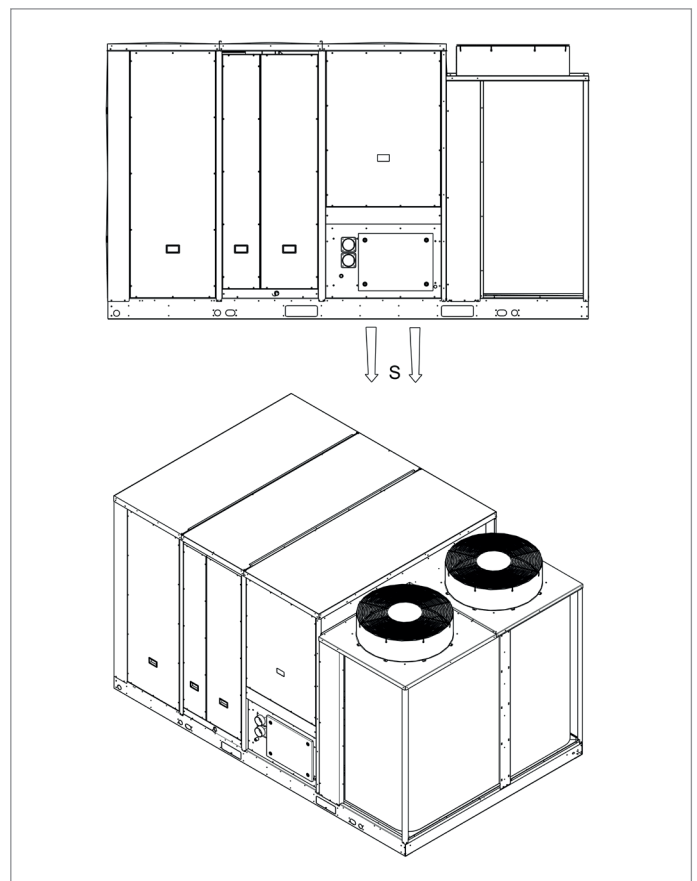

Fig. 8a – Gas heater standard location

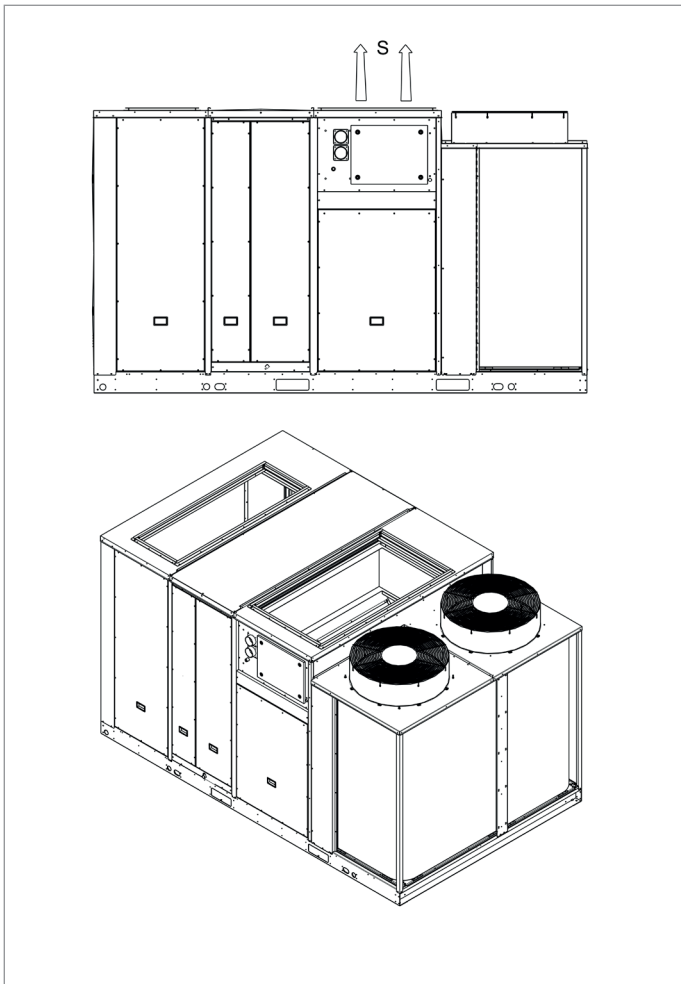

Fig. 8b – Gas heater optional location

### 12.1.1 - Heat Exchanger

Furnace and air/flue exchanger are entirely manufactured with stainless steel (with low carbon content) AISI 441 which assures maximum reliability and long life cycle.

The new cylinder shaped furnace and the air/flue exchangers, whose tube bundle is custom designed, guarantee performance that place PCH/new modules among the leading units for heat efficiency

### 12.1.2 - Premix Burner

The burner is entirely made of AISI 430 steel and undergoes specific engineering processing that guarantees top reliability and high thermal-mechanical performance.

### 12.1.3 - Electronic Card with Display

The microprocessor-based electronic card regulates continuous modulation of heat output and controls both the electrical fan for air/gas mixing and the gas valve. There is also a safety thermostat with manual reset

## 12.2 - Preliminary Checks Before Start-up

### NOTES:

Any work on the gas system must be carried out by qualified personnel.

This unit must be installed in accordance with local safety codes and regulations and can only be used in outdoor conditions.

Please read carefully the manufacturer's instructions before starting a unit.

Before commissioning a unit with gas burner, it is mandatory to ensure that the gas distribution system (type of gas, available pressure...) is compatible with the gas type, electrical supplies, adjustment and settings of the unit.

Check access and clearance around the unit. (Refer to the certified dimensional drawings)

- Combustion air inlet and burnt gas exhausts must not be obstructed in any way.

## 12.3 - Safety Instructions

### 12.3.1 - Fuel

Before starting up the heater, make sure that:

- The gas main supply data is compatible with the data stated on the nameplate
- The combustion air intake ducts (when fitted) and the fume exhaust pipes are those specified by the manufacturer
- The combustion air is supplied in such a way as to avoid even partial obstructions of the intake grille (caused by leaves etc.)
- The fuel intake internal and external seal is checked during the testing stage, as required by applicable standards
- The heater is supplied with the same type of fuel it has been designed for
- The system is correctly sized for such flow rate and is fitted with all safety and monitoring devices required by applicable standards
- The inside of the gas pipes and air distribution ducts for ducted heaters has been thoroughly cleaned
- The fuel flow rate is suitable for the power required by the heater
- The fuel supply pressure is between the range specified on the nameplate.

### 12.3.2 - Gas Leaks

If you smell gas:

- Do not operate electrical switches, telephones or any other object or device that could produce sparks
- Close the gas valves
- Call for qualified staff

## 12.4 - Installation of the Gas Heating Module

The gas heating module is supplied inside the rooftop unit available with up to 3 different gas heater models with modulating capacity for natural gas.

Refer to the certified drawings and wiring diagrams for the

mechanical and electrical connections. The following table shows available gas heater models for each rooftop size. The detailed technical data of each gas heating model is given in the table below;

Unit	Gas Heater Model		
	Low Heat	Medium Heat	High Heat
025	PCH034	PCH045	N/A
035	PCH034	PCH045	N/A
045	PCH045	PCH065	N/A
055	PCH045	PCH065	N/A
065	PCH065	PCH080	PCH105
075	PCH065	PCH080	PCH105
090	PCH065	PCH080	PCH105
105	PCH065	PCH080	PCH105
125	PCH105	PCH160	PCH210
140	PCH105	PCH160	PCH210
160	PCH105	PCH160	PCH210
190	2xPCH80	2xPCH105	N/A
220	2xPCH80	2xPCH105	N/A

Model	Unit	PCH034	PCH045	PCH065	PCH080	PCH105	PCH160	PCH210							
Type of Equipment		B23P-B53P-C13-C43-C53-C63-C83													
EC Certification		0476CQ0451													
NOx Class [EN1020:2009]		5													
		Heater Performance													
		Min	Max	Min	Max	Min	Max	Min	Max	Min	Max	Min	Max	Min	Max
Burner Heat Output (Hi)	kW	7,6	34,9	8,5	42,0	12,4	65,0	16,4	82,0	21,0	100,0	16,4	164,0	21,0	200,0
Useful Heat Output [ $P_{min}$ , $P_{rated}$ ]*	kW	8,1	33,6	9,0	40,5	13,4	62,9	17,8	80,0	22,8	97,2	17,8	160,1	22,8	194,3
Hi Efficiency (N.C.V.) [ $\eta_{pl}$ , $\eta_{nom}$ ]*	%	107,0	96,3	105,5	96,3	108,1	96,8	108,3	97,6	108,4	97,2	108,4	97,6	108,4	97,2
Hs Efficiency (G.C.V.) [ $\eta_{pl}$ , $\eta_{nom}$ ]*	%	96,4	86,8	95,1	86,8	97,4	87,2	97,6	87,9	97,7	87,5	97,6	87,9	97,7	87,5
Flue Losses with Burner On (Hi)	%	0,6	3,7	0,5	3,7	0,2	3,2	0,3	2,4	0,2	2,8	0,3	2,4	0,2	2,8
Flue Losses with Burner Off (Hi)	%	< 0,1		< 0,1		< 0,1		< 0,1		< 0,1		< 0,1		< 0,1	
Envelope Loss Factor [ $F_{env}$ ]* <sup>(1)</sup>	%	0%		0%		0%		0%		0%		0%		0%	
Seasonal Space Heating Energy Efficiency [Reg.EU/2281/2016] [ $\eta_{s,h}$ ]*	%	92,1		90,8		93,2		93,2		93,1		94,0		94,0	
Emission Efficiency [Reg.EU/2281/2016] [ $\eta_{s,low}$ ]*	%	97,3		97		97,4		97,1		97		97,9		97,9	
Max. Condensation <sup>(6)</sup>	l/h	0,9		1,1		2,1		3,3		2,7		6,6		5,4	
		Flue Gas Emissions													
Carbon monoxide - CO - (0% of O2) <sup>(2)</sup>	ppm	< 5		< 5		< 5		< 5		< 5		< 5		< 5	
Emissions of Nitrogen Oxides - NOx* (0% of O2) (Hi) <sup>(3)</sup>	mg/kWh	42		33		39		41		39		41		39	
Emissions of Nitrogen Oxides - NOx* (0% of O2) (Hs) <sup>(4)</sup>	mg/kWh	38		30		35		37		35		37		35	
Pressure Available at the Flue	Pa	90		100		120		120		120		120		120	
		Electrical Data													
Nominal Power Supply	V-Ph-Hz	230-1-50													
Rated Electricity Consumption [ $e_{l,min}$ - $e_{l,max}$ ]*	kW	0,011	0,074	0,024	0,082	0,015	0,097	0,020	0,123	0,020	0,130	0,020	0,246	0,020	0,260
Power Input in Stand-by [ $e_{l,sb}$ ]*	kW	0,005													
		Connections													
Size Gas Connection		UNI/ISO 228/1-G 3/4"													
Size Intake/Exhaust Pipes	mm	80/80		80/80		80/80		80/80		80/80		2 x 80/80		2 x 80/80	
		Air Side													
Air Flow Rate (15° C) <sup>(5)</sup>	m <sup>3</sup> /h	4.300		4.500		7.800		9.000		11.100		18.000		22.200	
Maximum Applicable Pressure	Pa	1.200		1.200		1.200		1.200		1.200		1.200		1.200	
		Weight													
Net Weight	kg	48		58		72		98		118		206		250	

\* Symbol of conformity with Reg.EU/2281/2016.

(1) The losses from the enclosure must be regarded as zero as the machine is installed in a roof top unit.

(2) Value referred to cat. H (G20).

(3) Weighted value to EN1020:2009 ref. to cat. H (G20), referred to net calorific value (Hi, N.C.V).

(4) Weighted value to EN1020:2009 ref. to cat. H (G20), referred to gross calorific value (Hs, G.C.V).

(5) Reference air flow rate for the calculation of yields and season energy efficiencies and emissions listed in the table

(6) Max. condensation produced acquired from testing at 30%Qn.

## 12.5 - Commissioning

### 12.5.1 - Gas Connection

- The gas supply must be done according to local safety codes and regulations.
- In any case the diameter of pipe-work connected must not be smaller than the diameter of the connection on the PCH module.
- Make sure that a shut-off isolation valve has been installed before each PCH module. The isolation valve must be connected to the main gas inlet supply pipe as close as possible to the appliance. For safety and accessibility reasons the isolation valve must not be fitted within the appliance gas valve compartment.
- Make sure that the gas service includes a filter and has been tested and purged in accordance with prescribed practice prior to commissioning and taking the appliance into service.
- Gas service pipes shall not be routed through any heated or fresh air ducts.
- Gas connection: ISO 228-1 G 3/4 " Refer to the certified drawings for the gas connection
- It is strictly prohibited to supply gas to the circuit with pressure higher than 60 mbar. Such pressures could cause the valve to break.

Each PCH module includes the following elements as shown below.

### 12.5.2 - Condensate Drain

- The condensate drain must be realized according to the local safety codes and regulations.
- Special attention must be paid to the condensate drain; an incorrectly installed drain, in fact, could jeopardize the correct operation of the equipment.
- Recommended drain needs to be connected to pipes, an open type connection (socket pipe), similar to the one illustrated in picture below must be installed to prevent ice forming in the pipe from blocked condensate drainage, and the ensuing build-up of condensate in the exchanger.
- Make sure that condensate drain has been connected for each PCH module. Refer to the certified drawings for the condensate drain

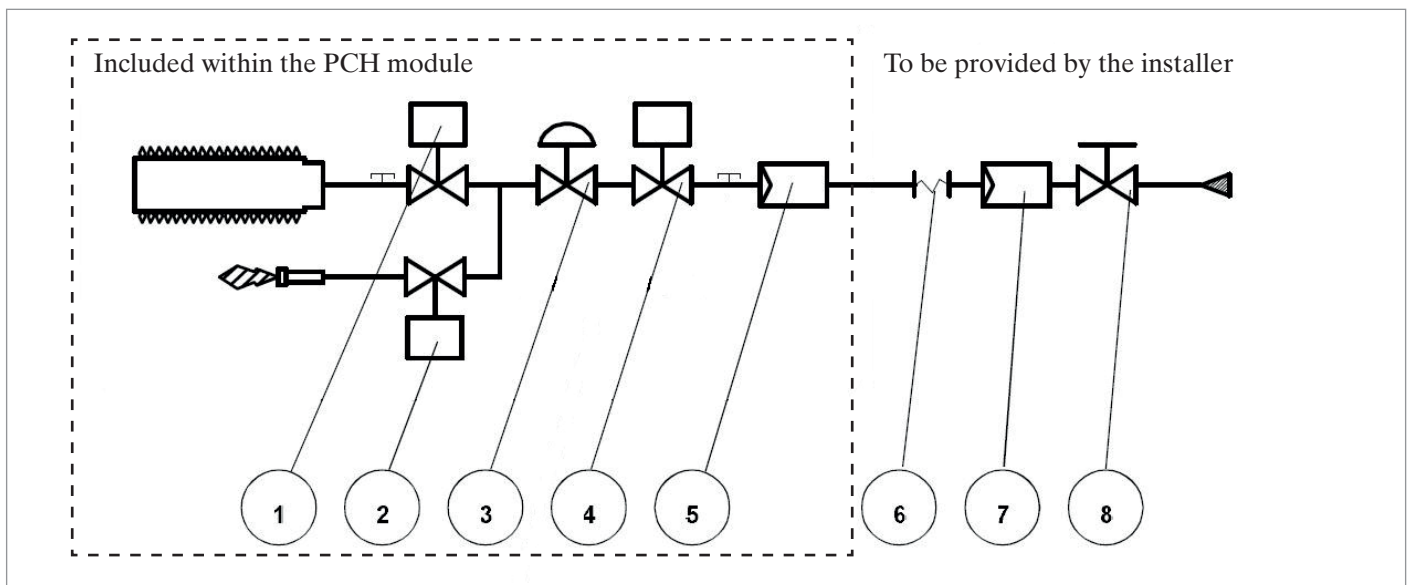
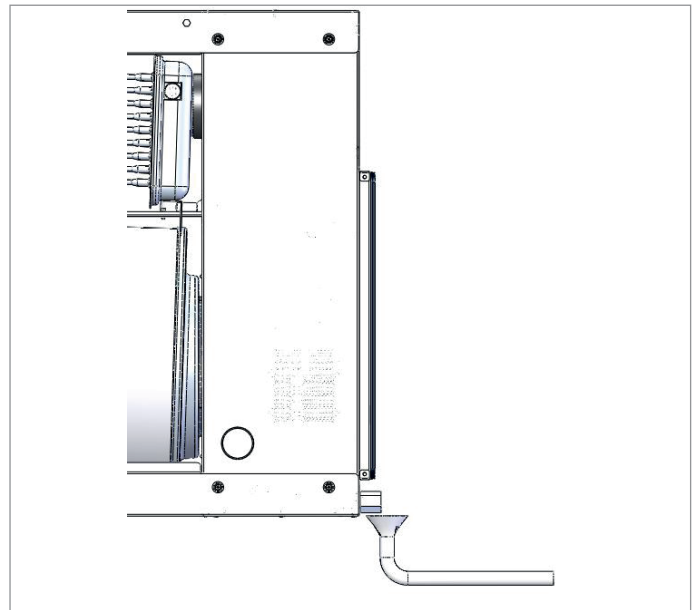

#### KEY

- 1 Main burner gas solenoid valve
- 2 Pilot burner gas solenoid valve
- 3 Pressure stabilizer
- 4 Safety gas solenoid valve

- 5 Gas filter (small section)
- 6 Anti-vibration joint
- 7 Gas filter (large section)
- 8 Isolation valve (gas valve)



### 12.5.3 - Flue Outlet and Combustion Air Inlet Connection

- The unit is delivered with a standard flue, but its connection must be done by the installer.
- If the standard flue is not suitable due to field connections, the flue design and connection must be done by the installer according to the local safety codes and regulations.
- For the flue, certified pipes and terminals must be used, taking into account that the modules are of a PCH condensing type
- The horizontal sections of flue must be installed with a slightly incline (1°- 3°) towards the heater, in order to prevent the build of condensation in the exhaust
- B23 type connection is recommended. Install the standard flue and the air inlet terminal supplied. Correctly position this terminal in which the «blanked off» side must ALWAYS face upwards as shown below in order to ensure no water can directly enter the inside of the heater
- Make sure that air inlet and flue outlet connections have been done for each PCH module. Refer to the certified drawings for air inlet and flue outlet

The “blanked off” side must ALWAYS face upwards

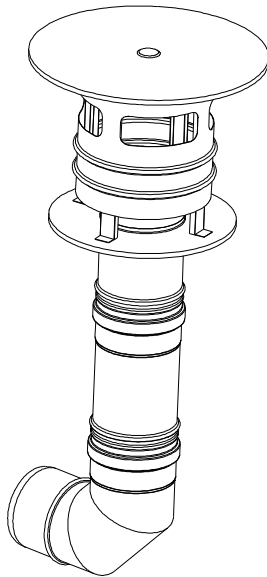

The “blanked off” side must ALWAYS face upwards

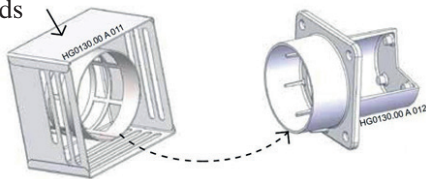

### 12.5.4 - Checks to be Carried Out Before Starting-up the Gas Burner

The PCH heater unit is supplied with settings entered and tested for the gas specified on the nameplate. Before turning on the PCH unit, check the following:

- 1- Check that the gas used is the right type for the unit to be used.
- 2- Check that there is a shut-off isolation valve fitted at the gas inlet of the unit.
- 3- Isolate the appliance from the electrical mains supply and turn off the gas supply to the appliance at the isolation valve.

- 4- The whole of the gas service installation including the meter must be inspected, tested for soundness and purged in accordance with appropriate requirements.

**NOTE:** The soundness of gas burner pipework has been checked. However during installation, connections may have been loosened. Check the soundness of the appliance pipework using a suitable gas leak detection solution. If any leaks are found they must be rectified immediately.

**CAUTION:** Never use a flame for checking gas soundness.

- 5- Check, with the pressure intake «IN» on the gas valve, that the pressure entering the valve corresponds to that required for the type of gas being used;
- 6- Check that electrical connections match wiring diagrams attached to the unit;
- 7- Check that efficient earthing connections have been completed, carried out as specified by current safety regulations;
- 8- Turn on the gas and electrical supplies.
- 9- Operate the appliance via the SmartVu control at the maximum rate: Refer to the start-up procedures in SETTING UP SMARTVU CONTROL section Increase the set temperature (room set point temperature) to a temperature higher than the actual room temperature.
- 10- At first RDY appears and when ON appears on the LCD display of PCH heater, the heater starts the ignition cycle.

**NOTE:** Frequently, when turned on for the first time, the pilot burner cannot ignite because there is air in the gas hose. This will lock out the equipment. You will need to reset the equipment and repeat the operation until it ignites.

### 12.6 - Combustion Analysis

The PCH heater is fitted with a burner that completely premixes air and gas. The air/gas mixing occurs inside the impeller on the motor-ventilator. The air taken into the impeller through the venturi tube, calibrated, creates a vacuum. The vacuum in the venturi is rebalanced by the gas valve, which is pneumatically controlled. The air pressure - gas pressure ratio is 1:1. This ratio

can be corrected by turning the offset adjustment screw (on the gas valve). The heater is supplied with the offset regulated and the screw sealed. A second adjustment can be done with the screw on the venturi, which regulates the value of maximum gas capacity and determines the amount of carbon dioxide (CO<sub>2</sub>) in the fumes. This adjustment is also made at the factory. The screw is not sealed to permit conversion to another type of gas, if desired. To adjust the level of CO<sub>2</sub>;

Wait until the heater is on. Check that the heater is at maximum power. Use the LCD display of PCH heater to reach the REG menu, then use the Hi and Lo commands to force operation at maximum or minimum capacity.

At maximum power, check again that the input pressure in the valve corresponds to that required; adjust if required.

Perform the combustion analysis for each module to verify that the level of CO<sub>2</sub> corresponds to figures in the table given below. If the measured value is different, turn the adjustment screw on the venturi. Unscrewing the screw will raise the level of CO<sub>2</sub>, screwing it down will lower the level.

Place the heater on minimum capacity, and verify that the level of CO<sub>2</sub> corresponds to figures in the table given below. If the figures do not match, turn the offset screw (screw down to raise and unscrew to lower) to adjust the level of CO<sub>2</sub> and repeat the procedure.

Type Of Gas G20															
Type of Equipment	Unit	PCH034		PCH045		PCH065		PCH080		PCH105		PCH160		PCH210	
		Min	Max	Min	Max	Min	Max	Min	Max	Min	Max	Min	Max	Min	Max
Thermal															
Category		According to the Country of Destination													
Supply Pressure	mbar	20 [Min 17- Max 25] *													
Ø Pilot Nozzle	mm	0,7													
Gas Consumption (15°C -1,013 mbar)	m <sup>3</sup> /h	0,80	3,69	0,90	4,44	1,31	6,88	1,74	8,68	2,22	10,58	3,48	17,36	4,44	21,16
Carbon Dioxide - CO <sub>2</sub> Content	%	8,7	9,1	8,7	9,1	8,7	9,1	8,7	9,1	8,5	9,1	8,5	9,1	8,5	9,1
Fume Temperature	°C	31	94	30	93	31	86	27	70	28	80	28	80	28	80
Fume Mass Flow Rate (Max)	kg/h	57		72		107		135		165		270		330	
Gas Orifice Plate	mm	7,4		7,5		11,0		12,2		15,8		15,8		15,8	
Air Orifice Plate	mm	Not Required													

\*For Hungary, the supply pressure is 25 mbar

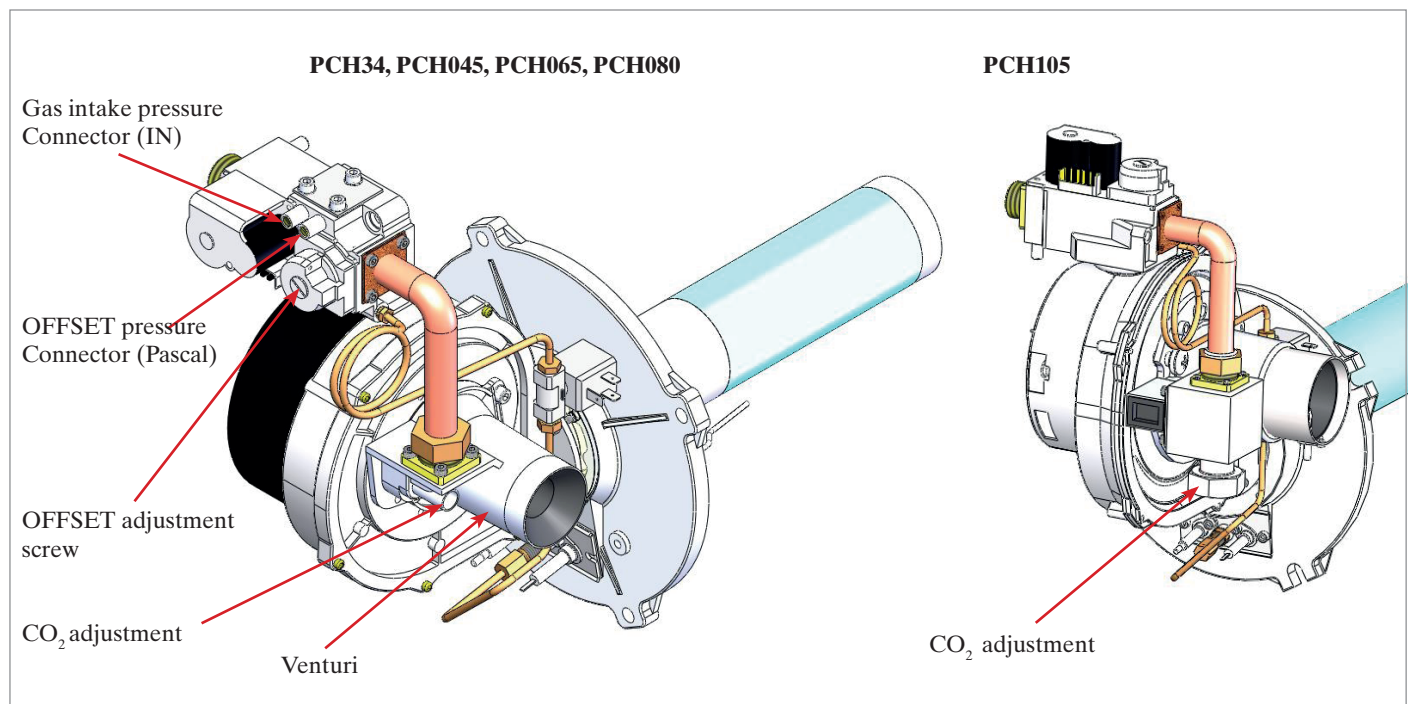

### 12.7 - Operating Sequence

If there is a call for heating, the operating sequence is as follows:

The equipment will immediately start the ventilating burner by pre-cleaning the combustion chamber for a preset length of time. After the pre-cleaning phase, the ignition phase starts: the equipment opens solenoid valve EV1 and, in parallel, solenoid valve EVP which supplies gas to the pilot burner. After detecting the pilot flame, the equipment opens the main gas valve EV2 to supply gas to the main burner. After a time of dual functioning of the two burners (pilot and main), the modulation PCB removes gas from the EVP valve and turns off the pilot burner. A single electrode detects the flame both for the pilot burner and the main burner. The ignition program lights the burner to obtain an intermediate level heat output, which corresponds to about 30% of the maximum output. Once the flame is stabilized for a few seconds at ignition power, the burner begins to modulate its output to reach maximum output, if required, in a variable length of time programmed into the modulation PCB.

During operation, the modulation PCB will regulate the heat output of the burner proportionally to the voltage (0-10 Vdc) coming from SmartVu control based on heat demand.

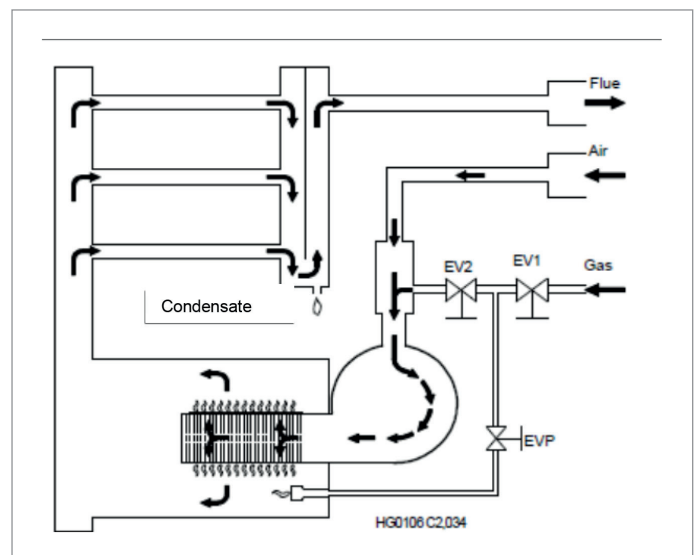

When the heating demand is satisfied, signaled in a voltage lower than the preset limit (0.5 Vdc), the modulation PCB turns off the burner; the fan continues to ventilate the combustion chamber, post-wash, for a preset length of time. Opening ON/OFF contact always causes the burner to stop without causing a fault.

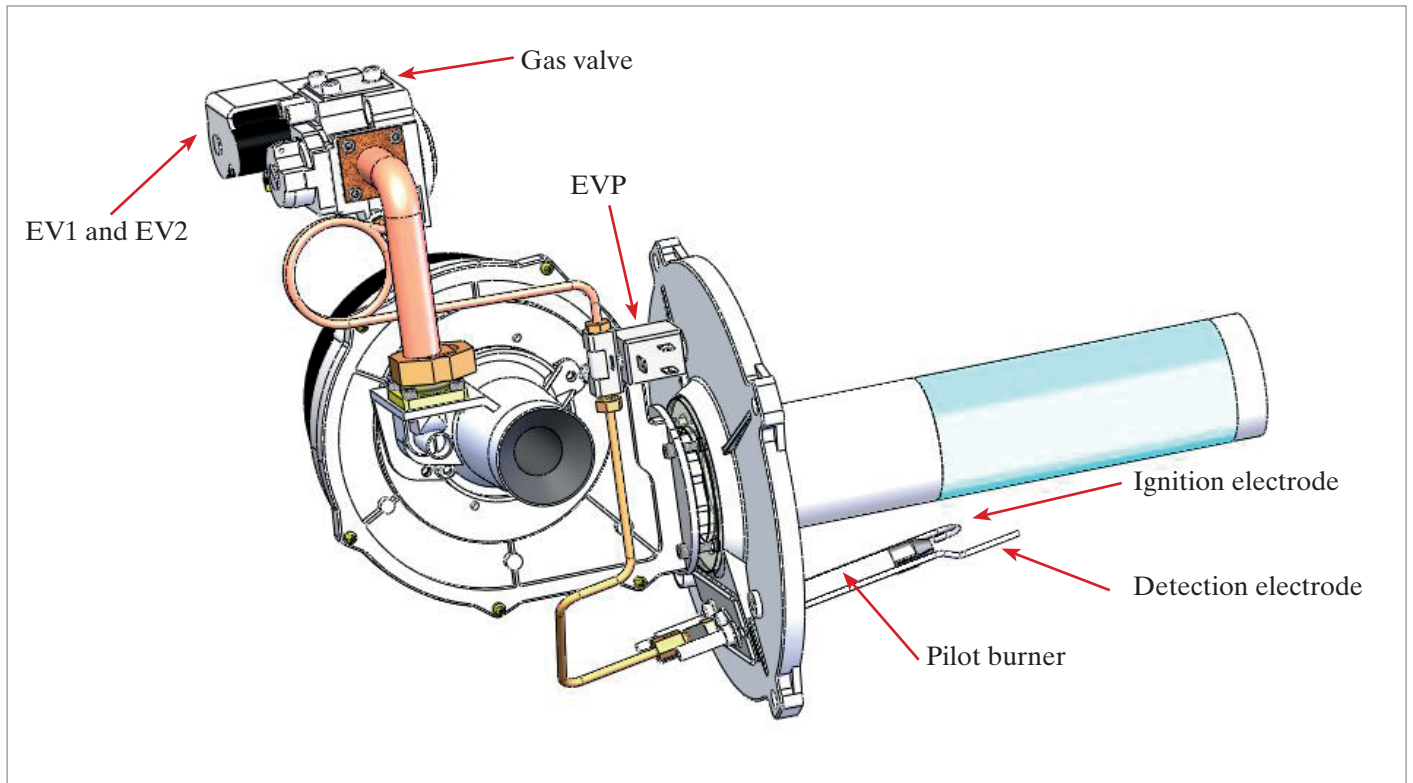

**Important Note:** The supply fan must be always ON before starting the heater and must be maintained ON for longer than three minutes after stopping the heater. This condition is always satisfied by the SmartVu control.

**12.8 - Maintenance Operations**

To keep the machine in efficient condition and guarantee a long lifetime of the heater, it is advisable to run some inspections every year, before turning it on for the season:

- 1) check the status of the start-up electrodes, detection electrodes and pilot flame;
- 2) check the status of fume exhaust and air intake ducts and terminals;
- 3) check the status of the venturi;
- 4) check and clean the exchanger and burner are clean;
- 5) check and clean the water trap
- 6) check the intake pressure at the gas valve;
- 7) check the function of the flame monitoring equipment;
- 8) check the safety thermostat(s);
- 9) check the ionization current.

**NOTE:** Operations at points 1, 2, 3, 4 and 5 must be performed after powering off the heater and closed the isolation shut-off valve. Operations at point 6, 7, 8 and 9 must be carried out with the heater on.

**12.8.1 - Inspection of Electrodes**

Dismantle the complete pilot flame and use a jet of compressed air to clean the mesh and nozzle. Check the integrity of the ceramic and use sandpaper to remove any oxidation on the metal parts of the electrodes. Check the

correct position of the electrodes (see drawing below). It is important that the detection electrode is at a tangent to the head of the pilot and not inside it. The start-up electrode must discharge onto the mesh of the pilot burner.

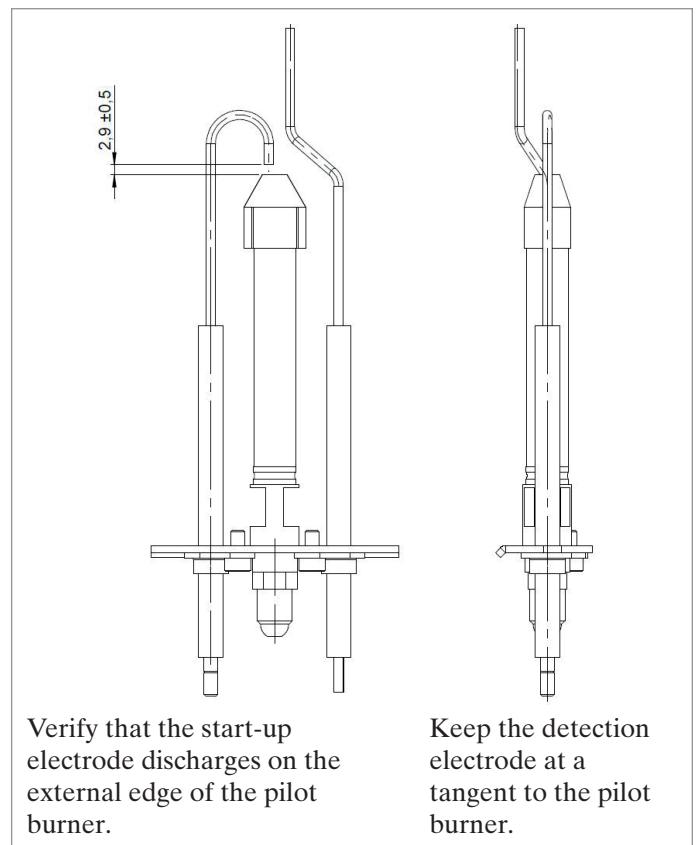

### 12.8.2 - Inspection of Fume Exhaust and air Intake Ducts

Visually inspect where possible or examine with specific tools to learn the status of the ducts. Remove dust that forms on the air intake terminal.

### 12.8.3 - Inspection and Cleaning of the Venturi

Remove any dirt at the mouth of the venturi with a brush, and be careful to not let it fall inside the piece.

### 12.8.4 - Inspection and Cleaning of the Exchanger and Burner

Perfect combustion in PCH heaters prevents dirt, which is normally caused by bad combustion. It is advisable, therefore, to not clean the exchanger and burner unless there are exceptional circumstances. An accumulation of dirt inside the exchanger could be revealed by a sizeable variation in the gas capacity that is not caused by improper functioning of the gas valve. Should it become necessary to clean the burner and/or exchanger, all of the gaskets mounted between the burner and the exchanger must be replaced.

### 12.8.5 - Inspection and Cleaning of the Water Trap

Clean the trap every year, and check the connections. Make sure there are no traces of metallic residue. If metallic residue has formed, increase the number of inspections.

### 12.8.6 - Inspection of Intake Gas Pressure

Verify that the intake pressure at the valve corresponds to the value required for the type of gas that you are using. This inspection must be done with the heater on at maximum heat output.

### 12.8.7 - Inspection of Flame Monitoring Equipment

With the heater operating, close the gas shut-off valve and check that the machine is locked out; this is indicated on the LCD display on the CPU PCB on the machine with code F10. Reopen the gas shut-off valve, reset the lockout and wait for the heater to restart.

### 12.8.8 - Inspection of the Safety Thermostat(s)

This procedure must be done with the heater operational and the burner on. Open the set of thermostats with an insulated tool [230 V], remove the fast-on from the safety thermostat, wait for the F20 lockout signal to appear on the LCD display on the CPU PCB on the machine. Close the set of thermostats again, then reset the lockout.

### 12.8.9 - Inspection of the Ionization Current

This procedure can be done directly from the LCD display by entering the I/O menu. The IOn parameter indicates the value of the ionization current, and the reading is as follows:

- 100, indicates that the value is more than 2 microAmperes, which is plenty for the equipment to function;
- from 0 to 100, indicates a value from 0 to 2 microAmperes; for example, 35 corresponds to 0.7 microAmperes, which is the minimum threshold detectable for the flame monitoring equipment.
- The value of the ionisation current must not be below 2 micro-Amperes. Lower values indicate: the detection electrode in a bad position, a rusted electrode or one about to fail.

## 12.9 - Control of PCH Heater

The PCH heater is fitted as standard with a multifunction LCD panel located inside the burner housing, which is used to control, configure and diagnose all operating parameters of the equipment. The instrument panel is fitted with a red 3 digit LCD display and four function keys:  $\ddagger$ , \$, ESC and ENTER; the display allows the user to view the heater operating mode and its faults. It allows our service center to change the main operating parameters.

### 12.9.1 - Viewing the Machine Status

The machine status is shown on the display by the following wordings:

rdy: the machine is on without burner flame, it is waiting for the ON control and/or the heat demand

ON: the machine is on with burner flame or is in the ignition phase;

OFF: the machine is turned off by the control on the LCD. Any heat demands will be ignored. To light the burner, the LCD must show "operation ON";

Fxx Fault detected. During normal operation, the display will show the writing ON if the burner is on; rdy when the heater is being switched off or the room temperature has been reached.

### 12.9.2 - List of Faults and Reset

The modulation PCB allows the operator to identify more than thirty different causes of faults. This makes it possible to manage each event very precisely. To reset the lockout, press both arrows simultaneously for a few seconds.

A complete list of faults, possible causes and possible solutions is shown below.

## IMPORTANT

**Following any operation on the appliance which has necessitated removal and replacement of any parts, the appliance shall be re-commissioned in accordance with the commissioning section of these instructions**

FAULT	DESCRIPTION	CAUSE	RESET
<b>Lockout caused by Flame - Caused by the flame monitoring equipment (TER)</b>			
F10	Failure to ignite flame after 4 attempts performed by the equipment.	<ul style="list-style-type: none"> <li>• Live and neutral reversed</li> <li>• Earth wire not connected.</li> <li>• Phase-phase connection without neutral.</li> <li>• Start-up electrode failed or badly positioned</li> <li>• Detection electrode failed or badly positioned</li> <li>• Detection electrode that moves or disperses to the earthing system when hot.</li> <li>• Condensation detection electrode defective or earthed</li> </ul>	Manual reset
F11	Untimely flame (detection when for the flame monitoring equipment there should not be a flame)		
F12	Ignition failure; not visible. The count, displayed in the history, indicates whether the heater has had problems with ignition.		Auto-reset
F13	The TER equipment does not accept the reset command from CPU-SMART	<ul style="list-style-type: none"> <li>• TER has finished its 5 reset attempts in the period of 15 minutes.</li> </ul>	Wait for 15 minutes or use the equipment reset device
F14	Lack of communication between TER equipment and CPU for more than 60 seconds	<ul style="list-style-type: none"> <li>• TER equipment or CPU-SMART PCB broken</li> <li>• Connections on the STB thermostat to earth</li> <li>• Capillary of the STB thermostat that discharges on the earth faston of the thermostat body</li> </ul>	Auto-reset
F15	The CPU-SMART PCB sent the ignition signal to the TER equipment which, after 300 seconds and with no lockout, has not communicated its correct operation status.	<ul style="list-style-type: none"> <li>• Blocked safety thermostat at start up</li> </ul>	Check contact closing
		<ul style="list-style-type: none"> <li>• Poor gas mains pressure</li> <li>• Low CO<sub>2</sub> value</li> <li>• Faulty TER equipment</li> </ul>	Manual reset, auto-reset after 5 minutes
F16	Generic equipment lockout	<ul style="list-style-type: none"> <li>• It indicates that if the heat request has remained active for more than 24 consecutive hours, the TER equipment has performed a control cycle switching temporarily to stand-by mode</li> </ul>	Manual reset, auto-reset after 5 minutes
F17	Internal malfunction of TER equipment that does not accept reset command from CPU-SMART	<ul style="list-style-type: none"> <li>• Faulty TER equipment</li> </ul>	Manual reset, auto-reset after 5 minutes
<b>Lockouts caused by temperature (safety lockouts)</b>			
F20	Activation of safety thermostat STB	<ul style="list-style-type: none"> <li>• Excess air temperature due to lack of air circulation</li> <li>• Safety thermostat broken or not connected</li> </ul>	Manual reset
F21	(NOT USED - Jumped) Input ID1 open	<ul style="list-style-type: none"> <li>• ID1 - IDC1 jumper missing</li> </ul>	Manual reset
<b>FAN lockout - burner fan</b>			
F30	Fan speed too low in start up phase - VAG	<ul style="list-style-type: none"> <li>• Burner fan broken.</li> <li>• FAN electric cables interrupted, not connected or wrongly connected</li> </ul>	Manual reset
F31	Fan speed too high in start up phase - VAG		
F32	Fan speed, during operation, outside minimum and maximum set parameters - VAG		Manual reset, auto-reset after 5 minutes
<b>NTC probes broken or missing</b>			
F41	Probe NTC1 error, air intake temperature	No signal from probe or broken probe	Auto-reset
<b>Over-temperature</b>			
F51	The temperature of the air intake probe NTC1>TH1	<ul style="list-style-type: none"> <li>• The minimum heat output of the PCH heater is oversized compared to the heat output required by the environment.</li> <li>• Check the TH1 parameter - air intake set point.</li> <li>• Cooling fan(s) inoperative</li> <li>• Air flow rate insufficient</li> </ul>	Auto-reset if NTC1< TH1-15
<b>Check ModBus communication</b>			
F60	Communication error between CPU-SMART PCB and ModBus, Smart Web or SMART Easy network	<ul style="list-style-type: none"> <li>• ModBus network is disconnected.</li> <li>• The address of the PCB is wrong and/or not configured in the ModBus network.</li> </ul>	Auto-reset
<b>No voltage</b>			
F75	No voltage during operation cycle (excluding stand-by); the fault is not visible on remote control but only counted.	<ul style="list-style-type: none"> <li>• No voltage during operation</li> </ul>	Auto-reset
<b>Internal malfunction of CPU-SMART PCB</b>			
F00	Internal malfunction of CPU-SMART PCB	<ul style="list-style-type: none"> <li>• Perform a manual reset of the PCB; replace the CPU-SMART PCB if the problem persists</li> </ul>	Manual reset

## 13 - OPTIONS

### 13.1 - Electric Heaters

Shielded electric resistance heaters are located before supply fan for 025, 035, 045, 055, 065, 075, 090 & 105 sizes and after supply fan for 125, 140, 160, 190 & 220 sizes and are fully factory-wired and tested. Each stage is protected against overloads by two thermal protectors. The low-limit protector with automatic overload protection and is set to 90°C. It is located less than 150 mm after electric heaters. Refer to the certified drawings and wiring diagrams for the electric heaters and to the SmartVu Control IOM for further information.

The electric heater data is as follows:

50 UC-(V)/UP-(V)	Option No	Min / Max Heat Output		Nominal Input Current	Capacity Steps
		kW			
025	122	9,0 / 18,0		26	2
	123	6,0 / 18,0 / 30,0		43	3
035	122	9,0 / 18,0		26	2
	123	6,0 / 18,0 / 30,0		43	3
045	121	6,9 / 20,7		30	2
	122	6,9 / 13,8 / 27,6		40	3
	123	13,8 / 27,6 / 41,4		60	3
055	121	6,9 / 20,7		30	2
	122	6,9 / 13,8 / 27,6		40	3
	123	13,8 / 27,6 / 41,4		60	3
065	121	9,0 / 18,0		26	2
	122	9,0 / 18,0 / 36,0		52	3
	123	18,0 / 36,0 / 54,0		78	3
075	121	9,0 / 18,0 / 27,0		39	3
	122	9,0 / 18,0 / 36,0		52	3
	123	18,0 / 36,0 / 54,0		78	3
090	121	9,0 / 18,0 / 27,0		39	3
	122	9,0 / 27,0 / 45,0		65	3
	123	18,0 / 45,0 / 72,0		104	3
105	121	9,0 / 18,0 / 27,0		39	3
	122	9,0 / 27,0 / 45,0		65	3
	123	18,0 / 45,0 / 72,0		104	3
125	121	11,1 / 22,2 / 44,4		64	3
	122	22,2 / 44,4 / 66,6		96	3
	123	22,2 / 55,5 / 99,9		144	3
140	121	11,1 / 33,3 / 55,5		80	3
	122	22,2 / 55,5 / 88,8		128	3
	123	33,3 / 77,7 / 133,2		192	3
160	121	11,1 / 33,3 / 55,5		80	3
	122	22,2 / 55,5 / 88,8		128	3
	123	33,3 / 77,7 / 133,2		192	3
190	121	9,0 / 18,0 / 36,0 / 54,0		78	4
	122	18,0 / 36,0 / 63,0 / 90,0		130	4
	123	36,0 / 72,0 / 108,0 / 144,0		208	4
220	121	9,0 / 18,0 / 36,0 / 54,0		78	4
	122	18,0 / 36,0 / 63,0 / 90,0		130	4
	123	36,0 / 72,0 / 108,0 / 144,0		208	4

Nominal Power Supply: 400V-3Ph-50Hz

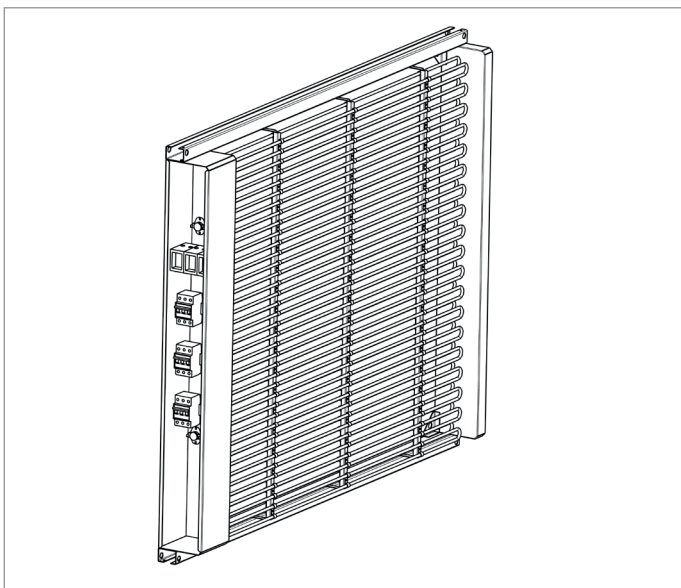

Fig. 9 - Electric heater option

### 13.2 - Hot Water Coil

The hot water coils offer a fully modulating proportional three-way valve as standard, with supply air temperature based control. They are located before supply fan for 025, 035, 045, 055, 065, 075, 090 & 105 sizes and after supply fan for 125, 140, 160, 190 & 220 sizes and are factory-fitted, wired and fully factory-tested. Frost protection is provided by a low-temperature sensor and the coils are equipped with a drain plug. Refer to the certified drawings and wiring diagrams for the water and electrical connections of the hot water coil and to the SmartVu Control IOM for further information.

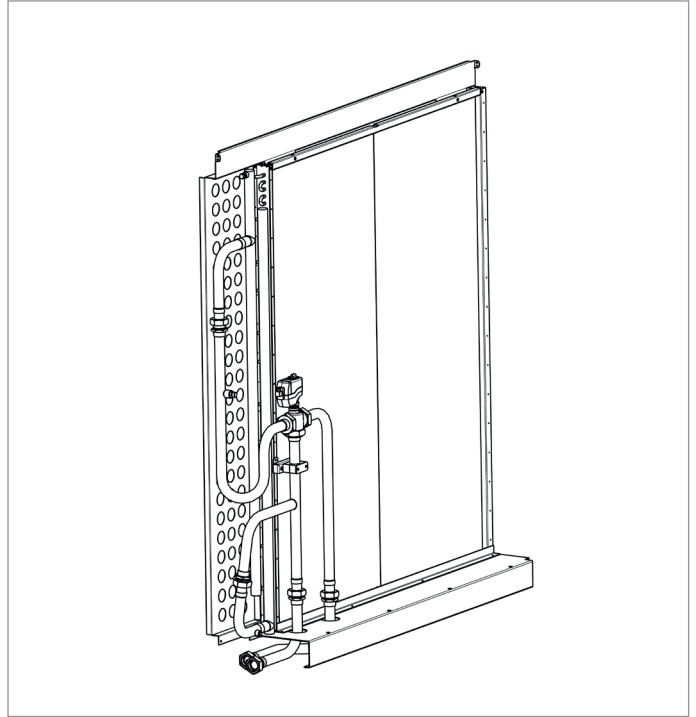

Fig. 10 - Hot water coil option

### 13.3 - Economizer (Thermostatic or Enthalpic)

When the outdoor conditions are maintained based on temperature or enthalpy (depending on the option fitted), free cooling can be provided using fresh air. The economizer is factory-fitted and tested before leaving the factory. The fresh air inlet is from top for standard duct configuration, (See Fig. 11a) and shall be from bottom for top or side return via top plenum. (See Fig. 11b)

The return air damper is operated by a 24 V actuator, and the fresh air damper is mechanically linked to this damper to open or close at opposite angles. During start-up, the return air damper is fully open, while the fresh air damper is fully closed.

The option also includes a factory-fitted fresh air hood that is folded during transportation to limit risks of damage and must be unfolded on site. Please refer to the certified drawings and wiring diagrams for the mechanical and electrical connections of the economizer and to the SmartVu Control IOM for further information.

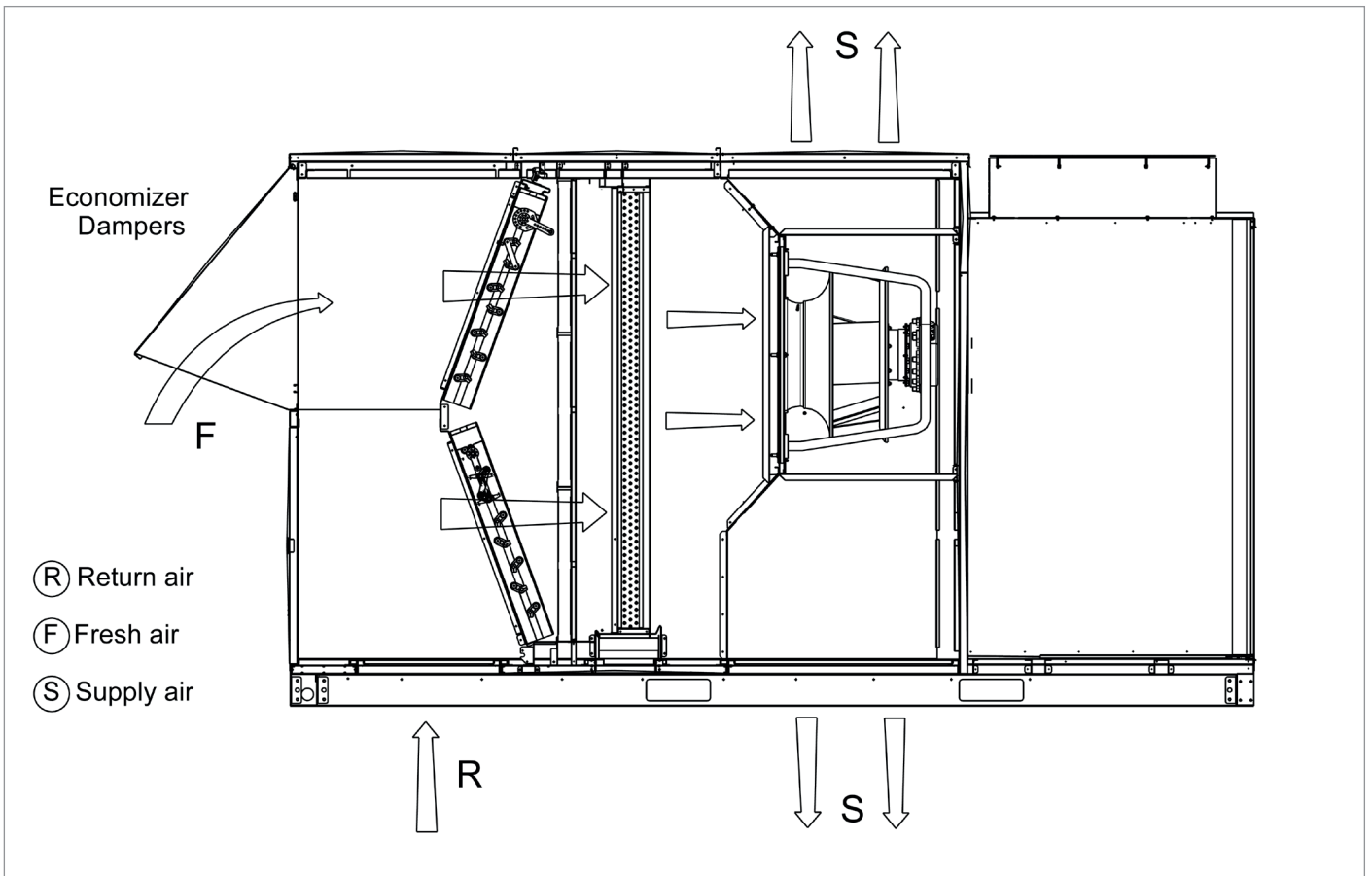

Fig. 11a – Economizer option - Fresh air inlet from top side

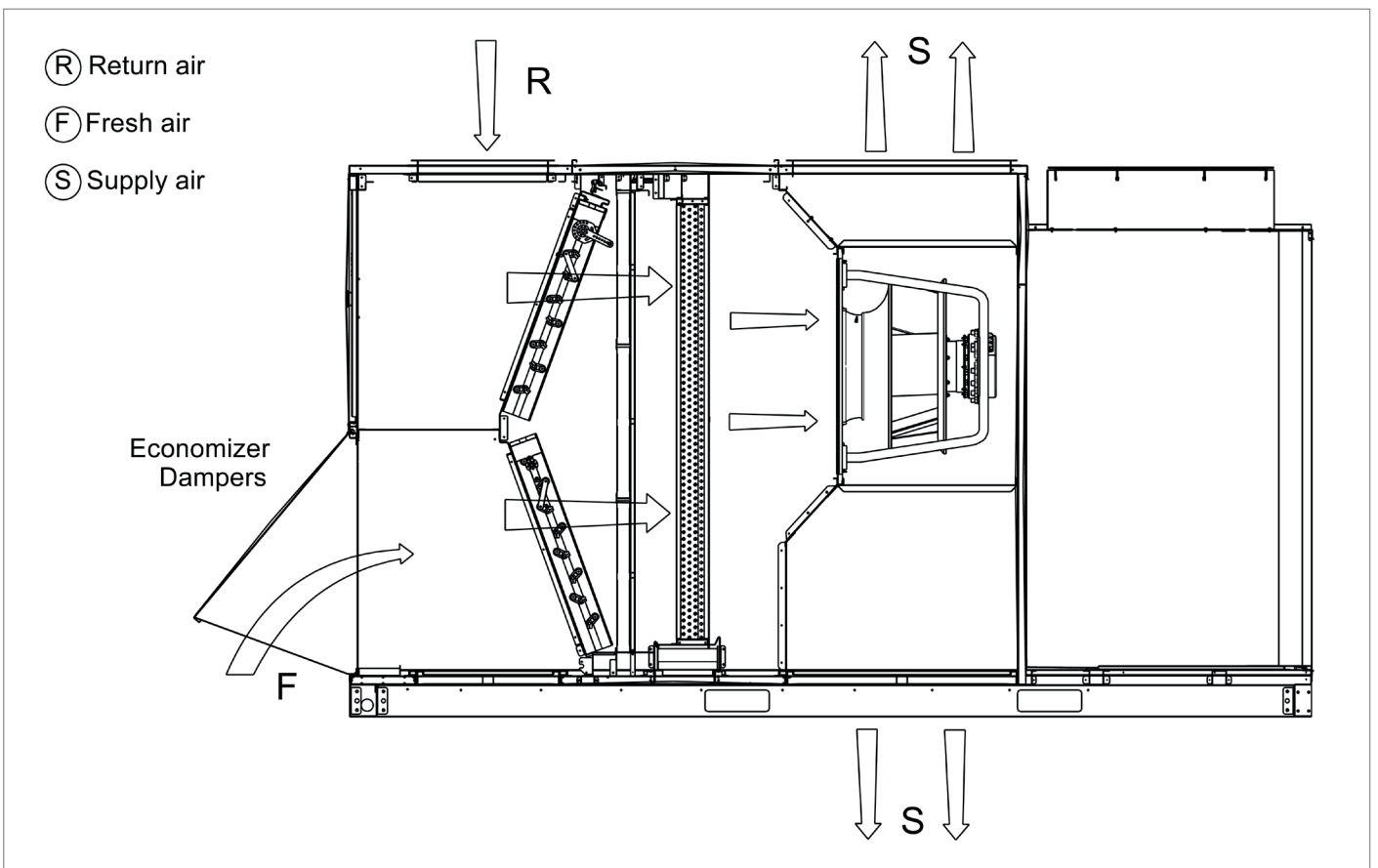

Fig. 11b – Economizer option - Fresh air inlet from bottom side

### 13.4 - Manual Outside Air Damper Option

Damper with direct link driven blades, can be preset to admit up to 40% outside air into the return air compartment. To adjust, loosen the securing screw and rotate the arm of the damper blades to the desired setting. Then retighten the screw to secure the damper blades. It also includes a factory fitted fresh air hood. The fresh air inlet is from top for standard duct configuration, (See Fig. 12a) and shall be from bottom for top or side return via top plenum. (See Fig. 12b)

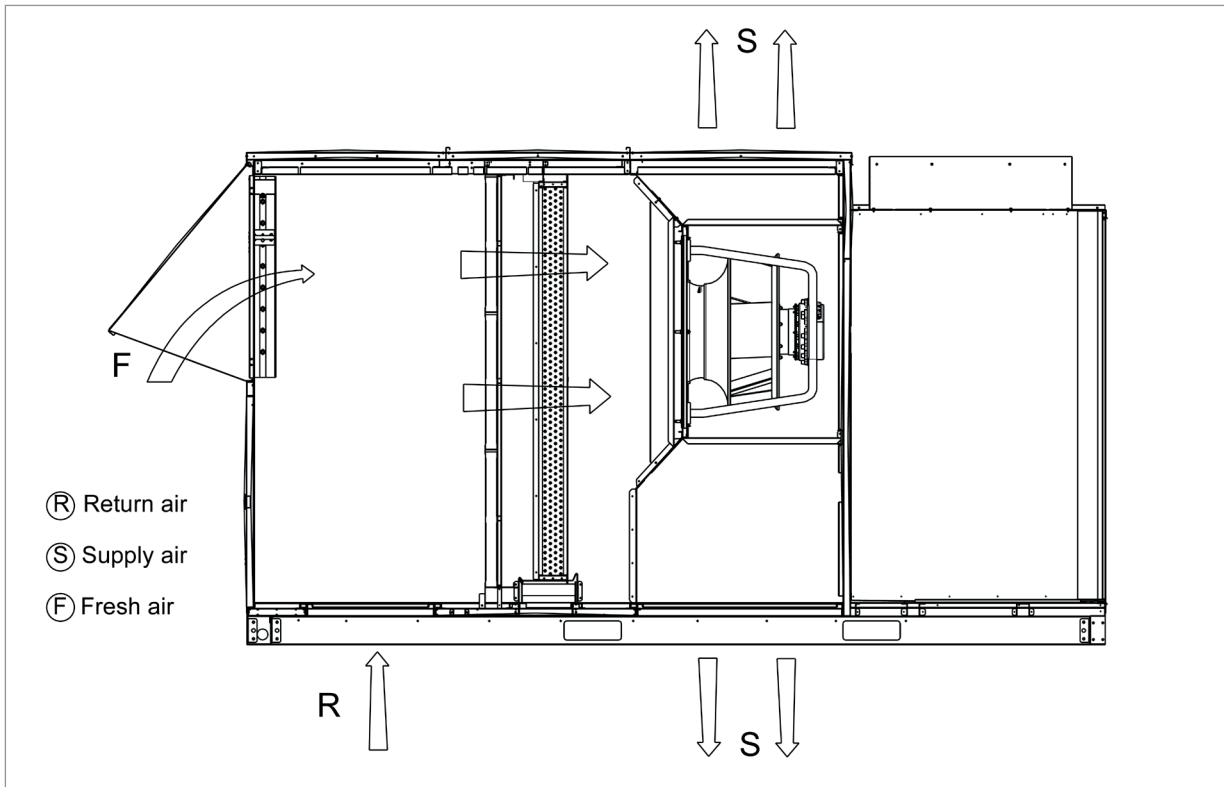

Fig. 12a –Manual outside air damper - Fresh air inlet from top side

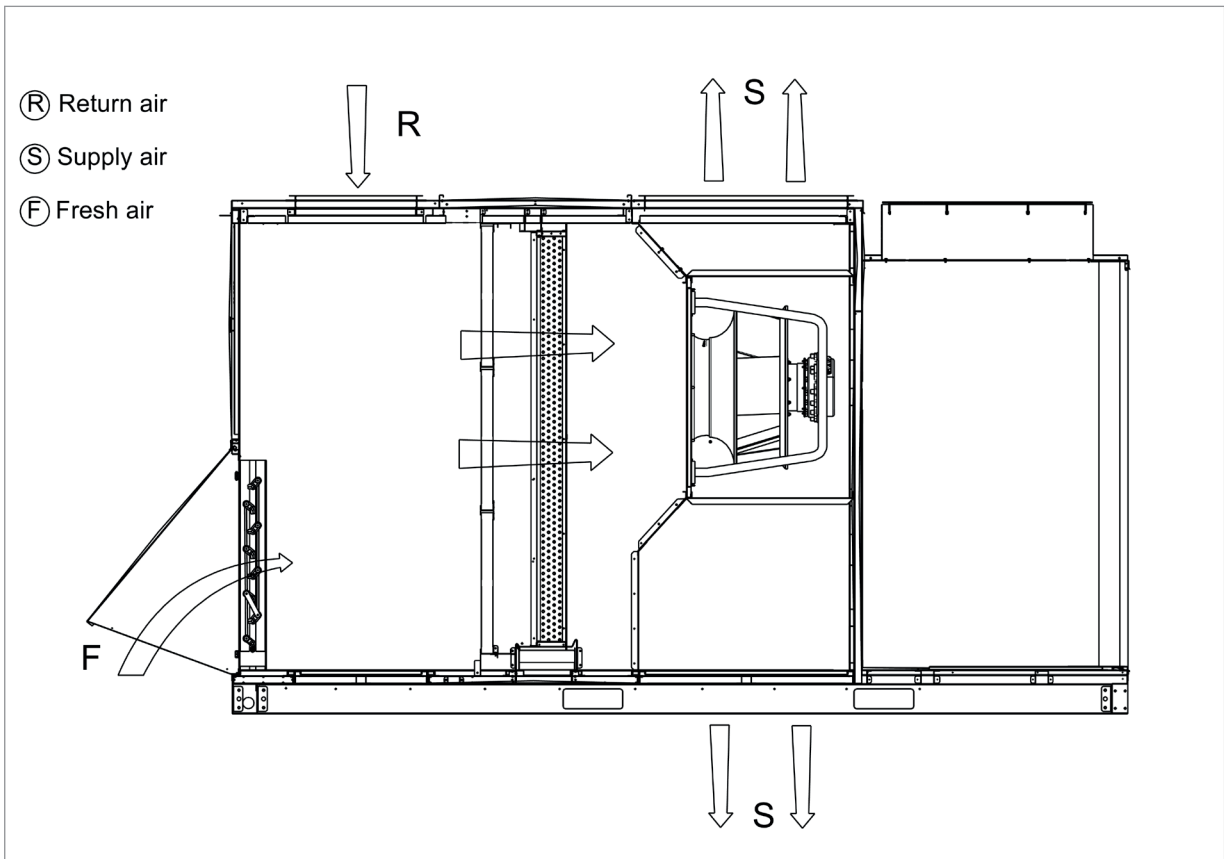

Fig. 12b – Manual outside air damper – Fresh air inlet from bottom side



**13.5 - Economizer with Electric Pre-Heater (Thermostatic or Enthalpic)**

The electric pre-heater is placed before the economizer fresh air damper to pre-heat fresh air depending on outdoor air conditions. Shielded electric resistance heaters are fully factory-wired and tested. Each stage is protected against overloads by two thermal protectors. The low-limit protector with automatic overload protection and is set to 90°C. It is located less than 150 mm after electric heaters. Refer to the certified drawings and wiring diagrams for the electric heaters and to the SmartVu Control IOM for further information.

The electric pre-heater data is as follows:

50 UC-(V)/UP-(V)	Option No	Min / Max Heat Output kW	Nominal Input Current A	Capacity Steps	Min. Fresh Air Flow Rate m3/h
025	146, 148	6,0 / 18,0	26	2	2.400
	147, 149	12,0 / 30,0	43	2	2.400
035	146, 148	6,0 / 18,0	26	2	2.400
	147, 149	12,0 / 30,0	43	2	2.400
045	146, 148	13,8 / 41,4	60	2	2.950
	147, 149	20,7 / 55,2	80	2	2.950
055	146, 148	13,8 / 41,4	60	2	2.950
	147, 149	20,7 / 55,2	80	2	2.950
065	146, 148	18,0 / 54,0	78	2	5.650
	147, 149	27,0 / 72,0	104	2	5.650
075	146, 148	18,0 / 54,0	78	2	5.650
	147, 149	27,0 / 72,0	104	2	5.650
090	146, 148	27,0 / 72,0	104	2	5.650
	147, 149	36,0 / 90,0	130	2	5.650
105	146, 148	27,0 / 72,0	104	2	5.650
	147, 149	36,0 / 90,0	130	2	5.650
125	146, 148	21,0 / 52,5 / 105,0	152	3	6.500
	147, 149	21,0 / 63,0 / 126,0	182	3	6.500
140	146, 148	21,0 / 52,5 / 105,0	152	3	6.500
	147, 149	21,0 / 63,0 / 126,0	182	3	6.500
160	146, 148	21,0 / 63,0 / 115,5	167	3	6.500
	147, 149	31,5 / 84,0 / 147,0	212	3	6.500
190	146, 148	22,2 / 66,6 / 122,1	176	3	6.500
	147, 149	33,3 / 88,8 / 155,4	224	3	6.500
220	146, 148	22,2 / 66,6 / 122,1	176	3	6.500
	147, 149	33,3 / 88,8 / 155,4	224	3	6.500

Nominal Power Supply: 400V-3Ph-50Hz

**13.6 - Power Exhaust Option**

When a large amount of fresh air is introduced into the room, power exhaust fans can be used to exhaust excessive air.

The exhaust fan runs when the outside air dampers are at least 50% open (adjustable value). It is overload protected. The exhaust fan is factory-fitted and tested before leaving the factory. The exhaust air outlet is from bottom for standard duct configuration, (See Fig. 13a) and shall be from top for top or side return via top plenum. (See Fig. 13b)

Refer to the certified drawings and wiring diagrams for the mechanical and electrical connections of the power exhaust and to the SmartVu Control IOM for further information.

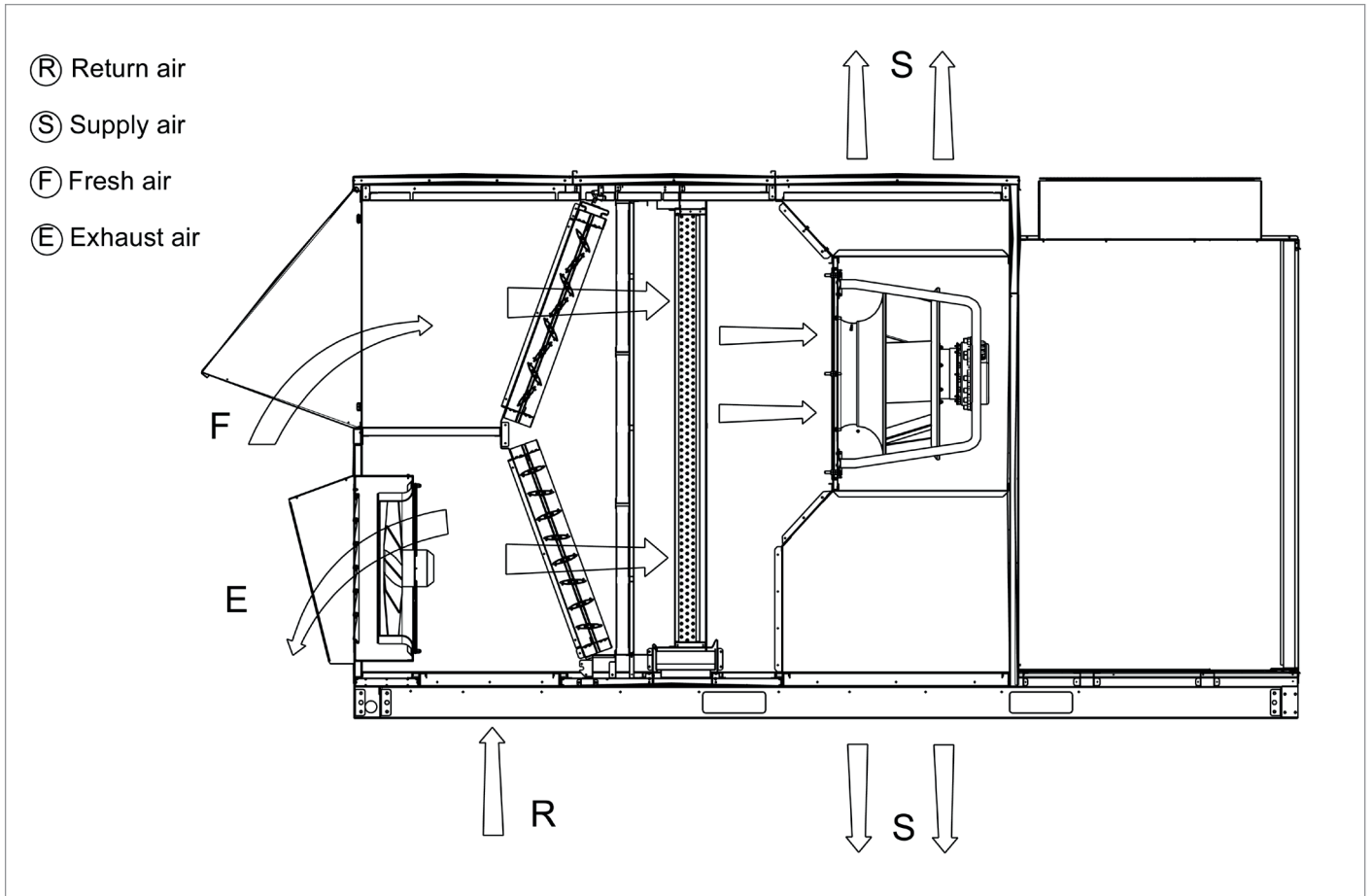

Fig. 13a – Power exhaust - Exhaust air outlet from bottom side

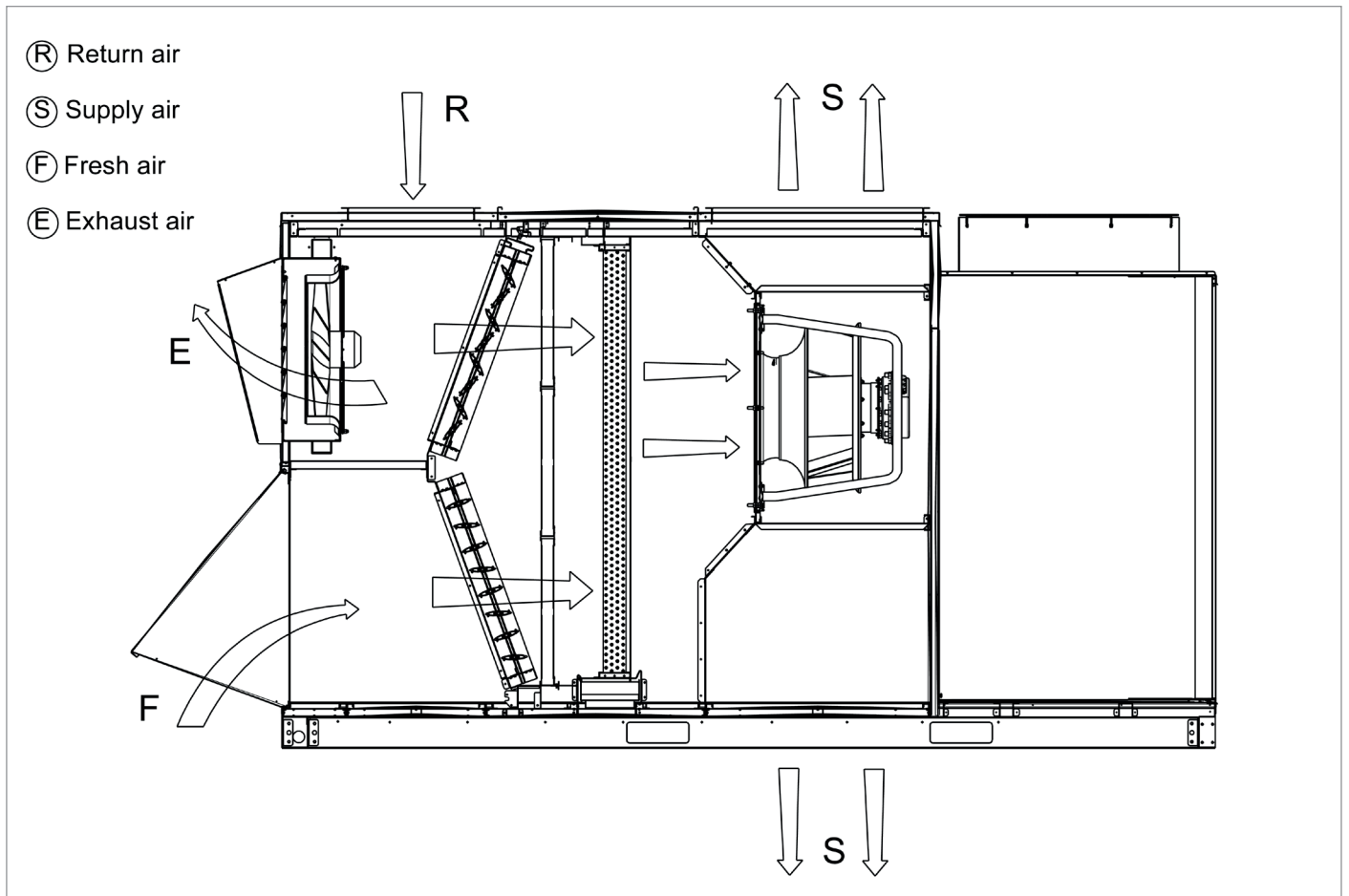
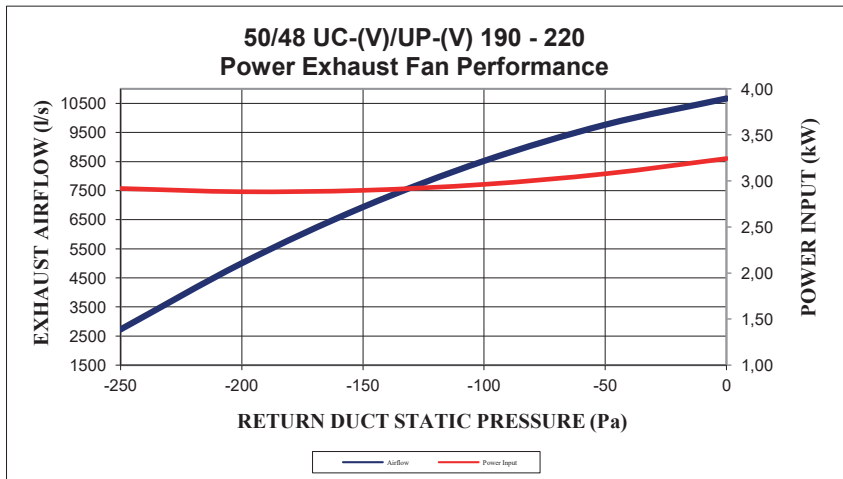
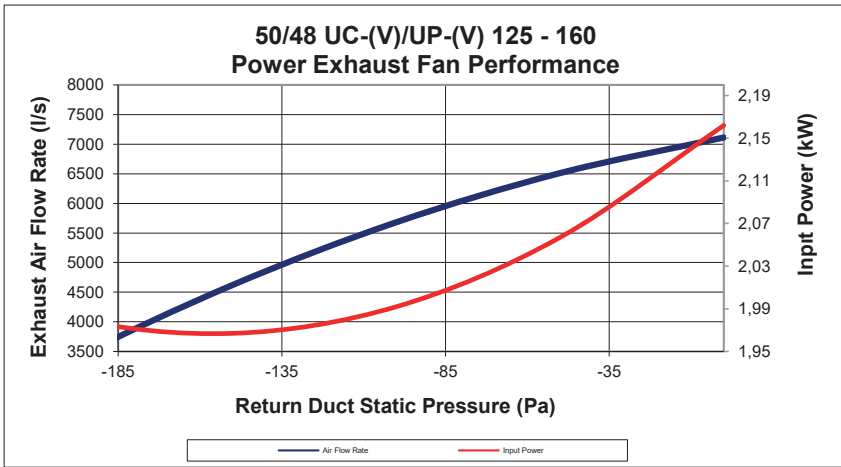
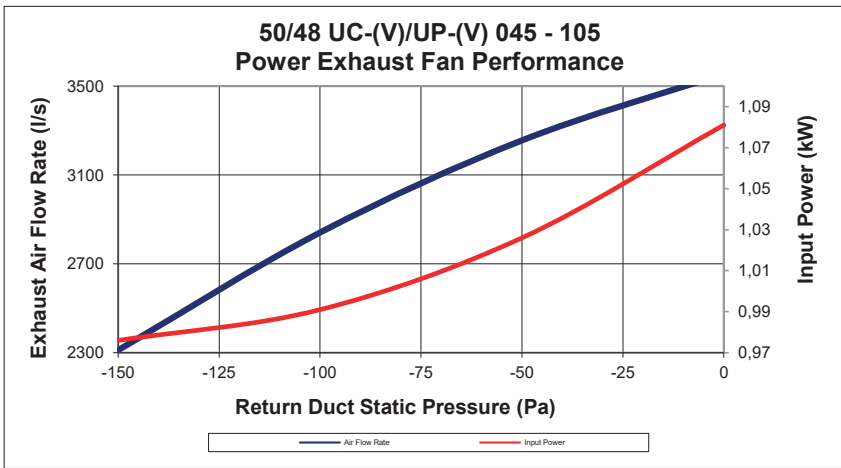
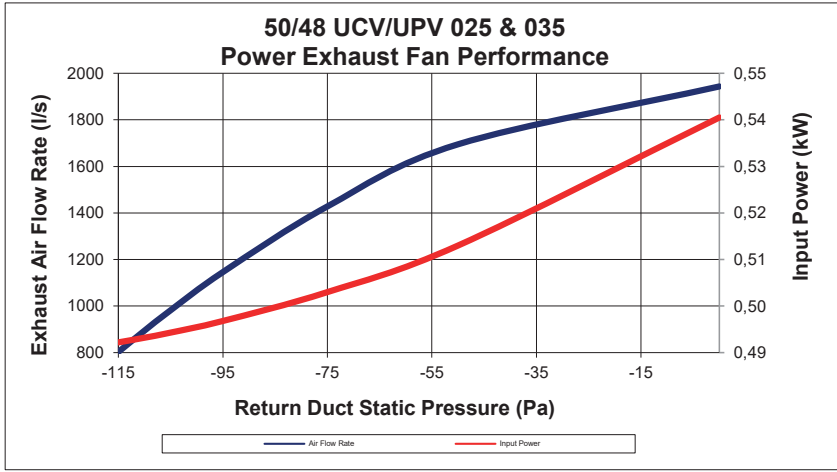

Fig. 13b – Power exhaust - Exhaust air outlet from top side

The power exhaust performance curves are shown below:



### 13.7 - Return Fan

This option assists the supply fan to overcome the return side pressure drop while running in series with the supply fan. It is also fitted with a damper to exhaust excessive air due to fresh air usage. The exhaust damper can be automatically adjusted, based on the economizer option. The return fan is factory-fitted, and submitted to functional tests before leaving the factory. The return fan is located at the bottom for standard duct configuration, (See Fig. 14a) and shall be located at the top for top or side return via top plenum. (See Fig. 14b)

Refer to the certified drawings and wiring diagrams for the mechanical and electrical connections of return air fan.

Air flow rate calibration shall be done during commissioning. It is also possible to run return fan with Building pressure control option. In this case, no calibration required. Please refer to the SmartVu Control IOM for further information.

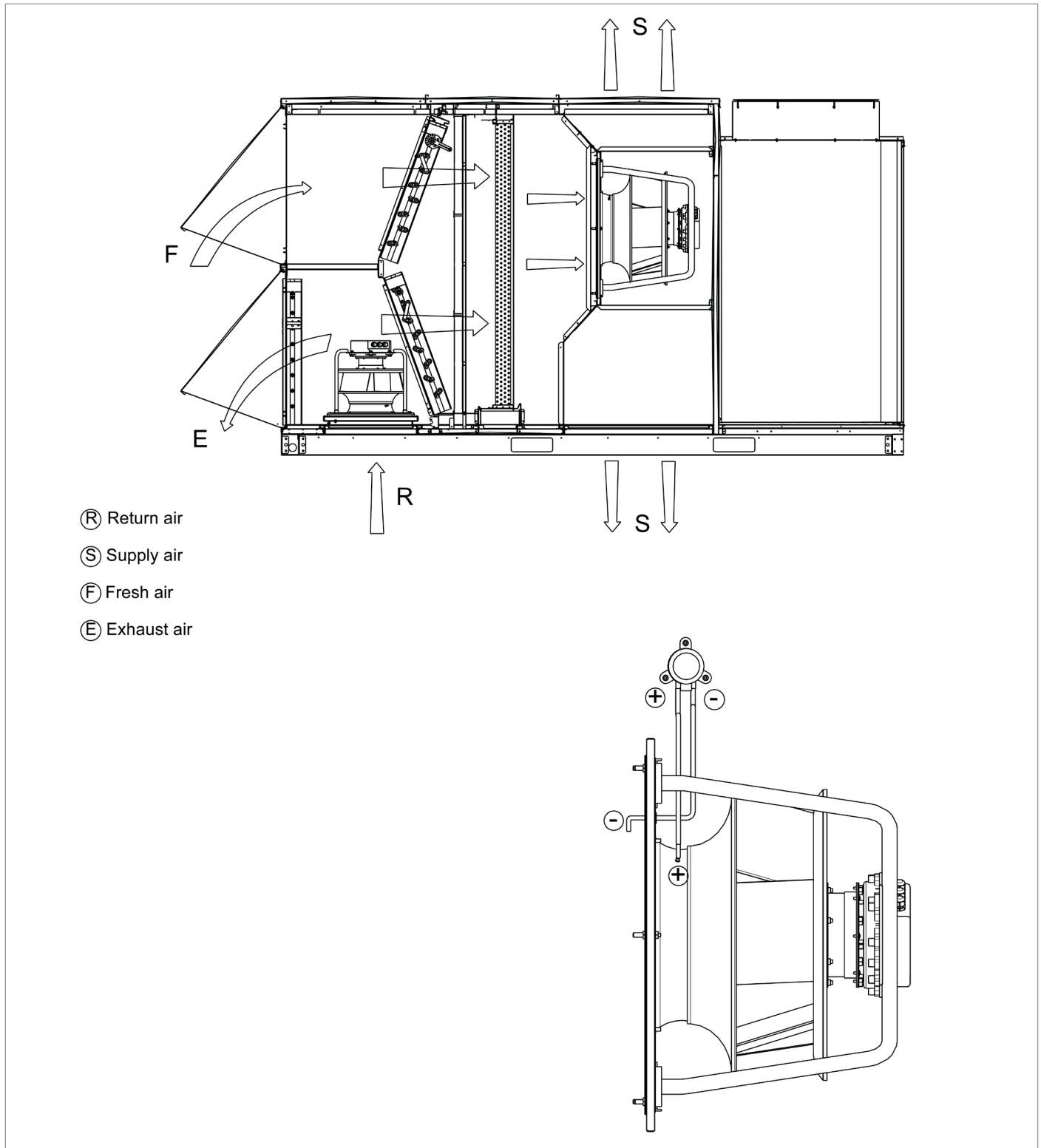
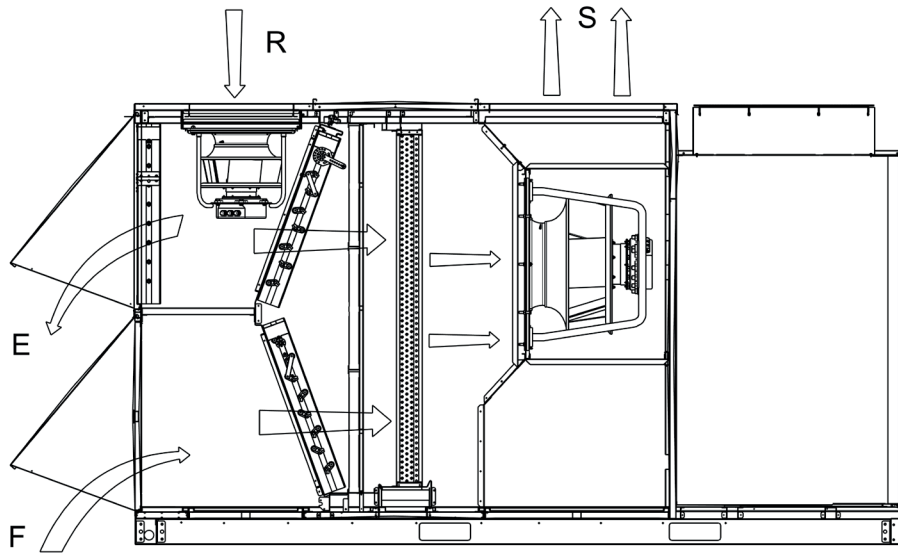

Fig. 14a – Return fan - Bottom



- Ⓜ Return air
- Ⓢ Supply air
- ⓕ Fresh air
- ⓔ Exhaust air

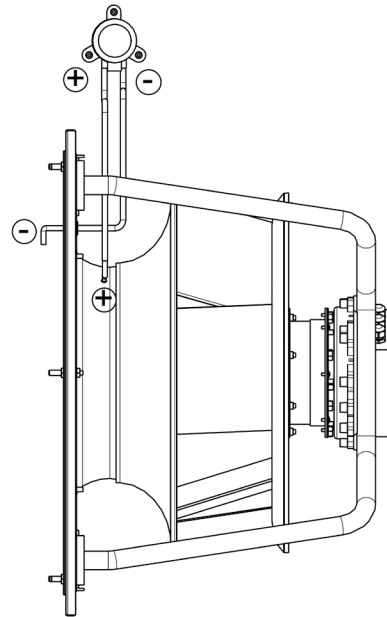
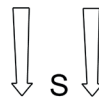

Fig. 14b – Return fan - Top

### 13.7.1 - Return Fan Performance

Return Fan Performance, 50/48 UC-(V)/UP-(V) 025 (Option 183 & 184)

Air Flow Rate (m <sup>3</sup> /h)	Unit External Static Pressure (Pa)																			
	50		150		250		350		450		550		650		750		850		950	
	rpm	kW	rpm	kW	rpm	kW	rpm	kW	rpm	kW	rpm	kW	rpm	kW	rpm	kW	rpm	kW	rpm	kW
3.240	1.980	0,29	2.112	0,39	2.246	0,50	2.377	0,62	2.511	0,75	2.638	0,87	2.762	0,99	2.881	1,12	2.995	1,24	3.106	1,39
3.420	2.081	0,33	2.209	0,43	2.334	0,53	2.458	0,67	2.586	0,79	2.709	0,92	2.829	1,06	2.944	1,18	3.056	1,30	3.164	1,47
3.600	2.183	0,37	2.307	0,46	2.423	0,58	2.541	0,71	2.662	0,84	2.783	0,98	2.897	1,13	3.010	1,25	3.119	1,39	3.224	1,55
3.780	2.284	0,41	2.405	0,51	2.512	0,63	2.626	0,76	2.741	0,90	2.858	1,04	2.969	1,19	3.078	1,32	3.184	1,48	3.287	1,64
3.960	2.385	0,45	2.502	0,56	2.602	0,68	2.712	0,80	2.823	0,96	2.935	1,10	3.044	1,24	3.148	1,41	3.251	1,56	3.353	1,71
4.140	2.486	0,50	2.600	0,61	2.694	0,73	2.800	0,87	2.907	1,02	3.014	1,17	3.120	1,32	3.221	1,48	3.320	1,64	3.421	1,78
4.320	2.587	0,55	2.698	0,66	2.787	0,79	2.889	0,93	2.993	1,08	3.095	1,23	3.197	1,39	3.296	1,55	3.394	1,72		
4.500	2.688	0,60	2.798	0,72	2.884	0,86	2.979	0,99	3.080	1,14	3.178	1,31	3.276	1,47	3.372	1,62				
4.680	2.790	0,65	2.898	0,79	2.981	0,92	3.071	1,06	3.167	1,21	3.263	1,38	3.356	1,55						
4.860	2.892	0,72	2.999	0,85	3.079	0,99	3.164	1,13	3.256	1,29	3.349	1,45								
5.040	2.994	0,79	3.100	0,92	3.179	1,06	3.260	1,22	3.347	1,37										
5.220	3.096	0,85	3.199	0,99	3.278	1,14	3.357	1,30												

Return Fan Performance, 50/48 UC-(V)/UP-(V) 035 (Option 183 & 184)

Air Flow Rate (m <sup>3</sup> /h)	Unit External Static Pressure (Pa)																	
	50		150		250		350		450		550		650		750		850	
	rpm	kW	rpm	kW	rpm	kW	rpm	kW	rpm	kW	rpm	kW	rpm	kW	rpm	kW	rpm	kW
4.500	2.476	0,50	2.627	0,66	2.770	0,80	2.907	0,96	3.044	1,13	3.185	1,28	3.328	1,43	3.468	1,60	3.603	1,78
4.752	2.602	0,57	2.746	0,73	2.882	0,87	3.010	1,05	3.142	1,22	3.273	1,38	3.411	1,55	3.547	1,72	3.679	1,89
5.004	2.728	0,65	2.866	0,80	2.993	0,96	3.116	1,14	3.241	1,31	3.365	1,50	3.496	1,68	3.628	1,84	3.751	2,05
5.256	2.855	0,72	2.985	0,88	3.106	1,06	3.222	1,24	3.344	1,41	3.465	1,62	3.582	1,81	3.709	2,00	3.827	2,21
5.508	2.981	0,80	3.105	0,98	3.221	1,16	3.333	1,33	3.451	1,53	3.568	1,73	3.677	1,94	3.793	2,15	3.908	2,36
5.760	3.107	0,90	3.225	1,08	3.337	1,25	3.449	1,45	3.561	1,65	3.673	1,85	3.777	2,08	3.883	2,30		
6.012	3.234	1,00	3.347	1,18	3.458	1,38	3.567	1,58	3.673	1,77	3.776	1,99	3.877	2,21	3.979	2,44		
6.264	3.360	1,10	3.473	1,31	3.580	1,51	3.685	1,70	3.784	1,91	3.881	2,13	3.979	2,35				
6.516	3.492	1,22	3.601	1,44	3.702	1,64	3.802	1,84	3.896	2,06	3.988	2,28						
6.768	3.626	1,36	3.730	1,57	3.825	1,78	3.920	1,99										
7.020	3.761	1,49	3.858	1,71	3.950	1,92												
7.272	3.892	1,64	3.985	1,85														

Return Fan Performance, 50/48 UC-(V)/UP-(V) 045 (Option 183 & 184)

Air Flow Rate (m <sup>3</sup> /h)	Unit External Static Pressure (Pa)															
	50		150		250		350		450		550		650		750	
	rpm	kW	rpm	kW	rpm	kW	rpm	kW	rpm	kW	rpm	kW	rpm	kW	rpm	kW
5.400	1.664	0,34	1.824	0,51	1.985	0,71	2.140	0,89	2.287	1,12	2.428	1,34	2.560	1,58	2.686	1,82
5.760	1.760	0,38	1.911	0,56	2.063	0,77	2.211	0,96	2.350	1,20	2.487	1,41	2.618	1,67	2.739	1,92
6.120	1.856	0,43	2.001	0,62	2.145	0,82	2.285	1,05	2.419	1,27	2.550	1,52	2.678	1,77	2.797	2,02
6.480	1.956	0,48	2.094	0,68	2.229	0,88	2.361	1,13	2.491	1,35	2.616	1,62	2.740	1,88	2.857	2,14
6.840	2.059	0,55	2.190	0,74	2.315	0,97	2.441	1,21	2.566	1,45	2.687	1,72	2.804	1,99	2.919	2,27
7.200	2.162	0,61	2.285	0,82	2.402	1,05	2.523	1,29	2.642	1,56	2.760	1,82	2.873	2,11	2.984	2,40
7.560	2.264	0,68	2.382	0,91	2.491	1,13	2.607	1,39	2.719	1,66	2.835	1,93	2.944	2,23		
7.920	2.361	0,76	2.479	0,99	2.580	1,22	2.690	1,49	2.800	1,76	2.910	2,06				
8.280	2.458	0,85	2.575	1,08	2.670	1,34	2.774	1,60	2.882	1,88	2.987	2,19				
8.640	2.556	0,93	2.671	1,19	2.762	1,44	2.859	1,70	2.965	1,00						
9.000	2.654	1,02	2.767	1,30	2.856	1,55	2.950	0,92								
9.360	2.752	1,13	2.863	1,41	2.952	0,84										

Return Fan Performance, 50/48 UC-(V)/UP-(V) 055 (Option 183 & 184)

Air Flow Rate (m <sup>3</sup> /h)	Unit External Static Pressure (Pa)															
	50		150		250		350		450		550		650		750	
	rpm	kW	rpm	kW	rpm	kW	rpm	kW	rpm	kW	rpm	kW	rpm	kW	rpm	kW
7.200	2.183	0,74	2.307	0,93	2.423	1,16	2.541	1,43	2.662	1,68	2.783	1,97	2.897	2,25	3.010	2,49
7.560	2.284	0,81	2.405	1,02	2.512	1,26	2.626	1,52	2.741	1,79	2.858	2,09	2.969	2,37	3.078	2,65
7.920	2.385	0,90	2.502	1,13	2.602	1,36	2.712	1,61	2.823	1,92	2.935	2,21	3.044	2,49	3.148	2,81
8.280	2.486	0,99	2.600	1,23	2.694	1,46	2.800	1,73	2.907	2,04	3.014	2,33	3.120	2,63	3.221	2,96
8.640	2.587	1,09	2.698	1,33	2.787	1,58	2.889	1,86	2.993	2,16	3.095	2,47	3.197	2,78	3.296	3,10
9.000	2.688	1,19	2.798	1,45	2.884	1,71	2.979	1,99	3.080	2,28	3.178	2,62	3.276	2,94	3.372	3,24
9.360	2.790	1,30	2.898	1,58	2.981	1,84	3.071	2,12	3.167	2,43	3.263	2,76	3.356	3,09		
9.720	2.892	1,44	2.999	1,71	3.079	1,97	3.164	2,27	3.256	2,58	3.349	2,90				
10.080	2.994	1,57	3.100	1,83	3.179	2,12	3.260	2,43	3.347	2,73						
10.440	3.096	1,71	3.199	1,98	3.278	2,29	3.357	2,59								
10.800	3.198	1,86	3.296	2,14	3.378	2,44										
11.160	3.299	2,01	3.394	2,29												

Return Fan Performance, 50/48 UC-(V)/UP-(V) 065 (Option 183 & 184)

Air Flow Rate (m³/h)	Unit External Static Pressure (Pa)																	
	50		150		250		350		450		550		650		750		850	
	rpm	kW	rpm	kW	rpm	kW	rpm	kW	rpm	kW	rpm	kW	rpm	kW	rpm	kW	rpm	kW
8.100	1.721	0,63	1.834	0,87	1.958	1,16	2.079	1,42	2.198	1,76	2.315	2,06	2.427	2,32	2.529	2,63	2.628	2,95
8.532	1.805	0,69	1.911	0,96	2.029	1,24	2.146	1,54	2.262	1,87	2.373	2,19	2.481	2,47	2.581	2,79	2.679	3,10
8.964	1.888	0,78	1.990	1,05	2.101	1,32	2.213	1,65	2.326	1,97	2.434	2,29	2.535	2,64	2.633	2,95	2.729	3,25
9.396	1.972	0,87	2.070	1,13	2.175	1,43	2.282	1,76	2.390	2,08	2.495	2,42	2.592	2,79	2.686	3,12	2.781	3,44
9.828	2.056	0,96	2.151	1,23	2.249	1,54	2.352	1,87	2.456	2,18	2.556	2,55	2.652	2,92	2.742	3,27	2.836	3,64
10.260	2.139	1,05	2.232	1,35	2.325	1,66	2.424	1,97	2.521	2,32	2.618	2,69	2.712	3,05	2.802	3,44		
10.692	2.221	1,16	2.314	1,46	2.401	1,77	2.496	2,08	2.588	2,47	2.682	2,84	2.774	3,20	2.863	3,60		
11.124	2.304	1,27	2.396	1,58	2.479	1,88	2.569	2,23	2.658	2,61	2.747	2,99	2.837	3,37				
11.556	2.386	1,38	2.479	1,69	2.556	2,02	2.643	2,38	2.729	2,75	2.814	3,16						
11.988	2.468	1,49	2.561	1,82	2.635	2,18	2.718	2,52	2.801	2,85	2.885	3,32						
12.420	2.550	1,61	2.643	1,97	2.715	2,32	2.793	2,67	2.876	2,99								
12.852	2.633	1,76	2.725	2,12	2.795	2,47	2.873	2,82										

Return Fan Performance, 50/48 UC-(V)/UP-(V) 075 (Option 183 & 184)

Air Flow Rate (m³/h)	Unit External Static Pressure (Pa)																					
	50		150		250		350		450		550		650		750		850		950		1050	
	rpm	kW	rpm	kW	rpm	kW	rpm	kW	rpm	kW	rpm	kW	rpm	kW	rpm	kW	rpm	kW	rpm	kW	rpm	kW
8.892	1.859	0,78	1.986	1,06	2.096	1,34	2.200	1,64	2.307	1,96	2.415	2,29	2.520	2,61	2.619	2,98	2.716	3,33	2.809	3,67	2.902	4,06
9.360	1.947	0,88	2.071	1,15	2.178	1,43	2.277	1,77	2.378	2,10	2.481	2,41	2.583	2,77	2.679	3,15	2.773	3,50	2.866	3,86	2.958	4,28
9.828	2.035	0,98	2.156	1,25	2.261	1,57	2.366	1,90	2.451	2,25	2.550	2,56	2.647	2,94	2.742	3,31	2.832	3,68	2.924	4,09	3.014	4,50
10.296	2.124	1,07	2.241	1,36	2.344	1,70	2.437	2,03	2.527	2,37	2.620	2,75	2.714	3,11	2.806	3,47	2.896	3,88	2.985	4,32	3.073	4,73
10.764	2.213	1,17	2.327	1,50	2.428	1,83	2.518	2,16	2.605	2,53	2.692	2,93	2.782	3,28	2.872	3,65	2.963	4,10	3.050	4,54	3.134	4,96
11.232	2.304	1,31	2.414	1,63	2.512	1,96	2.601	2,32	2.685	2,70	2.767	3,10	2.853	3,46	2.945	3,89	3.033	4,33	3.117	4,75	3.198	5,17
11.700	2.395	1,44	2.501	1,77	2.597	2,11	2.684	2,49	2.765	2,87	2.845	3,26	2.930	3,70	3.020	4,14	3.106	4,56	3.188	4,98		
12.168	2.486	1,58	2.589	1,91	2.682	2,28	2.768	2,67	2.847	3,04	2.927	3,46	3.012	3,95	3.098	4,39	3.182	4,81				
12.636	2.578	1,71	2.676	2,09	2.768	2,46	2.852	2,84	2.931	3,24	3.012	3,70	3.095	4,17	3.178	4,65						
13.104	2.668	1,88	2.764	2,26	2.854	2,64	2.937	3,03	3.017	3,43	3.097	3,93	3.178	4,40								
13.572	2.758	2,06	2.852	2,44	2.940	2,82	3.022	3,22	3.101	3,62	3.181	4,16										
14.040	2.849	2,24	2.940	2,61	3.025	2,99	3.106	3,41	3.185	3,81	3.265	4,37										

Return Fan Performance, 50/48 UC-(V)/UP-(V) 090 (Option 183 & 184)

Air Flow Rate (m³/h)	Unit External Static Pressure (Pa)																				
	50		150		250		350		450		550		650		750		850		950		
	rpm	kW	rpm	kW	rpm	kW	rpm	kW	rpm	kW	rpm	kW	rpm	kW	rpm	kW	rpm	kW	rpm	kW	
9.540	1.981	0,92	2.103	1,19	2.210	1,48	2.307	1,82	2.406	2,16	2.507	2,47	2.607	2,84	2.703	3,21	2.796	3,57	2.888	3,95	
10.080	2.083	1,03	2.201	1,30	2.306	1,64	2.399	1,97	2.492	2,32	2.587	2,66	2.683	3,03	2.776	3,40	2.866	3,78	2.957	4,21	
10.620	2.186	1,14	2.301	1,46	2.402	1,79	2.493	2,12	2.581	2,48	2.670	2,87	2.761	3,23	2.851	3,58	2.943	4,03	3.030	4,47	
11.160	2.290	1,28	2.401	1,61	2.499	1,94	2.588	2,29	2.672	2,68	2.755	3,07	2.842	3,43	2.933	3,85	3.022	4,29	3.107	4,72	
11.700	2.395	1,44	2.501	1,77	2.597	2,11	2.684	2,49	2.765	2,87	2.845	3,26	2.930	3,70	3.020	4,14	3.106	4,56	3.188	4,98	
12.240	2.501	1,60	2.602	1,93	2.696	2,31	2.781	2,69	2.860	3,07	2.940	3,50	3.024	3,98	3.110	4,43	3.194	4,84			
12.780	2.606	1,76	2.703	2,14	2.794	2,52	2.878	2,89	2.958	3,31	3.038	3,77	3.121	4,24	3.203	4,72					
13.320	2.710	1,97	2.804	2,34	2.893	2,72	2.976	3,13	3.056	3,58	3.136	4,04	3.217	4,50							
13.860	2.814	2,17	2.906	2,55	2.992	2,96	3.074	3,39	3.153	3,84	3.233	4,30									
14.400	2.918	2,37	3.007	2,79	3.091	3,22	3.171	3,64													
14.940	3.023	2,61	3.109	3,05	3.191	3,47															
15.480	3.128	2,88	3.212	3,30																	

Return Fan Performance, 50/48 UC-(V)/UP-(V) 105 (Option 183 & 184)

Air Flow Rate (m <sup>3</sup> /h)	Unit External Static Pressure (Pa)																			
	50		150		250		350		450		550		650		750		850		950	
	rpm	kW	rpm	kW	rpm	kW	rpm	kW	rpm	kW	rpm	kW	rpm	kW	rpm	kW	rpm	kW	rpm	kW
11.520	1.503	0,82	1.622	1,19	1.730	1,58	1.833	1,95	1.934	2,38	2.035	2,76	2.132	3,19	2.225	3,67	2.314	4,12	2.400	4,62
12.060	1.568	0,90	1.682	1,29	1.785	1,67	1.884	2,08	1.981	2,53	2.079	2,91	2.174	3,37	2.266	3,84	2.353	4,30	2.437	4,80
12.600	1.633	1,01	1.743	1,39	1.840	1,77	1.936	2,22	2.030	2,67	2.125	3,09	2.218	3,56	2.307	4,01	2.393	4,49		
13.140	1.699	1,11	1.805	1,48	1.896	1,92	1.989	2,35	2.080	2,79	2.171	3,29	2.262	3,75	2.350	4,20	2.435	4,69		
13.680	1.765	1,21	1.867	1,59	1.953	2,05	2.042	2,49	2.132	2,95	2.218	3,49	2.308	3,95	2.393	4,41	2.476	4,89		
14.220	1.832	1,31	1.929	1,73	2.011	2,18	2.096	2,62	2.184	3,13	2.269	3,66	2.354	4,15	2.437	4,63				
14.760	1.897	1,43	1.990	1,86	2.070	2,31	2.151	2,79	2.236	3,30	2.320	3,83	2.400	4,38						
15.300	1.960	1,57	2.052	2,00	2.130	2,44	2.206	2,97	2.290	3,47	2.372	4,00	2.449	4,58						
15.840	2.024	1,70	2.115	2,13	2.190	2,61	2.263	3,15	2.343	3,64	2.423	4,19								
16.380	2.087	1,83	2.177	2,27	2.252	2,79	2.322	3,31	2.398	3,83										
16.920	2.151	1,96	2.240	2,45	2.314	2,97	2.382	3,48	2.456	4,03										
17.460	2.215	2,12	2.303	2,63	2.376	3,14	2.443	3,67												

Return Fan Performance, 50/48 UC-(V)/UP-(V) 125 (Option 183 & 184)

Air Flow Rate (m <sup>3</sup> /h)	Unit External Static Pressure (Pa)																	
	50		150		250		350		450		550		650		750		850	
	rpm	kW	rpm	kW	rpm	kW	rpm	kW	rpm	kW	rpm	kW	rpm	kW	rpm	kW	rpm	kW
15.480	1.432	1,23	1.531	1,70	1.614	2,17	1.692	2,68	1.774	3,22	1.854	3,76	1.934	4,37	2.012	4,98	2.088	5,57
16.200	1.493	1,37	1.589	1,86	1.670	2,32	1.745	2,88	1.823	3,42	1.901	3,98	1.976	4,63	2.052	5,23	2.126	5,81
16.920	1.552	1,53	1.648	2,02	1.728	2,52	1.800	3,09	1.873	3,63	1.948	4,24	2.022	4,88	2.094	5,50		
17.640	1.611	1,69	1.706	2,19	1.786	2,73	1.855	3,29	1.924	3,89	1.997	4,51	2.068	5,13	2.137	5,75		
18.360	1.671	1,85	1.766	2,41	1.844	2,95	1.912	3,51	1.978	4,16	2.048	4,79	2.116	5,39				
19.080	1.731	2,02	1.824	2,62	1.903	3,17	1.969	3,78	2.033	4,42	2.100	5,08						
19.800	1.791	2,24	1.883	2,83	1.960	3,42	2.026	4,04	2.089	4,67								
20.520	1.851	2,45	1.942	3,04	2.017	3,69	2.083	4,29										
21.240	1.912	2,66	2.000	3,31	2.074	3,96	2.139	4,55										
21.960	1.973	2,89	2.058	3,58	2.131	4,22												
22.680	2.036	3,17	2.117	3,84														
23.400	2.099	3,44																

Return Fan Performance, 50/48 UC-(V)/UP-(V) 140 (Option 183 & 184)

Air Flow Rate (m <sup>3</sup> /h)	Unit External Static Pressure (Pa)																			
	50		150		250		350		450		550		650		750		850		950	
	rpm	kW	rpm	kW	rpm	kW	rpm	kW	rpm	kW	rpm	kW	rpm	kW	rpm	kW	rpm	kW	rpm	kW
16.740	1.133	1,08	1.235	1,58	1.322	2,10	1.402	2,67	1.487	3,31	1.569	3,92	1.649	4,63	1.723	5,30	1.794	6,04	1.863	6,76
17.550	1.181	1,18	1.282	1,72	1.366	2,23	1.443	2,86	1.523	3,49	1.602	4,16	1.680	4,87	1.754	5,55	1.825	6,32	1.892	7,07
18.360	1.229	1,32	1.329	1,87	1.411	2,41	1.485	3,05	1.561	3,68	1.637	4,39	1.711	5,11	1.785	5,84	1.855	6,61		
19.170	1.277	1,45	1.376	2,01	1.455	2,61	1.528	3,24	1.599	3,91	1.673	4,62	1.745	5,34	1.817	6,14	1.886	6,89		
19.980	1.325	1,59	1.422	2,18	1.499	2,81	1.570	3,43	1.640	4,14	1.709	4,86	1.780	5,60	1.849	6,43				
20.790	1.373	1,73	1.468	2,38	1.543	3,01	1.613	3,64	1.680	4,37	1.746	5,11	1.815	5,89	1.883	6,70				
21.600	1.422	1,86	1.514	2,58	1.587	3,20	1.656	3,89	1.722	4,61	1.786	5,37	1.852	6,19						
22.410	1.470	2,06	1.560	2,77	1.632	3,42	1.700	4,13	1.764	4,84	1.828	5,66	1.891	6,50						
23.220	1.518	2,26	1.606	2,96	1.678	3,67	1.744	4,37	1.808	5,11	1.870	5,95								
24.030	1.566	2,46	1.653	3,18	1.724	3,93	1.788	4,62	1.852	5,41										
24.840	1.614	2,65	1.698	3,44	1.769	4,18	1.834	4,91	1.897	5,72										
25.650	1.662	2,87	1.744	3,69	1.815	4,44	1.880	5,22												

Return Fan Performance, 50/48 UC-(V)/UP-(V) 160 (Option 183 & 184)

Air Flow Rate (m <sup>3</sup> /h)	Unit External Static Pressure (Pa)																	
	50		150		250		350		450		550		650		750		850	
	rpm	kW	rpm	kW	rpm	kW	rpm	kW	rpm	kW	rpm	kW	rpm	kW	rpm	kW	rpm	kW
18.540	1.239	1,35	1.339	1,90	1.421	2,45	1.495	3,09	1.570	3,72	1.645	4,44	1.719	5,16	1.792	5,91	1.862	6,67
19.440	1.293	1,50	1.392	2,06	1.469	2,67	1.542	3,30	1.613	3,99	1.685	4,70	1.757	5,42	1.827	6,24	1.896	6,99
20.340	1.347	1,65	1.443	2,27	1.518	2,90	1.589	3,52	1.658	4,24	1.725	4,97	1.796	5,73	1.864	6,55		
21.240	1.400	1,80	1.494	2,49	1.567	3,11	1.637	3,78	1.703	4,50	1.768	5,24	1.836	6,05	1.903	6,85		
22.140	1.454	2,00	1.545	2,71	1.617	3,34	1.685	4,05	1.750	4,76	1.814	5,56	1.878	6,39				
23.040	1.507	2,22	1.596	2,92	1.668	3,62	1.734	4,32	1.798	5,04	1.861	5,88						
23.940	1.560	2,43	1.647	3,15	1.719	3,90	1.783	4,59	1.847	5,38	1.908	6,20						
24.840	1.614	2,65	1.698	3,44	1.769	4,18	1.834	4,91	1.897	5,72								
25.740	1.667	2,89	1.750	3,72	1.820	4,46	1.885	5,26										
26.640	1.721	3,17	1.801	4,00	1.872	4,80												
27.540	1.774	3,45	1.852	4,28														
28.440	1.827	3,73	1.904	4,60														



Return Fan Performance, 50/48 UC-(V)/UP-(V) 190 (Option 183 & 184)

Air Flow Rate (m <sup>3</sup> /h)	Unit External Static Pressure (Pa)																			
	50		150		250		350		450		550		650		750		850		950	
	rpm	kW	rpm	kW	rpm	kW	rpm	kW	rpm	kW	rpm	kW	rpm	kW	rpm	kW	rpm	kW	rpm	kW
23.760	1.079	1376	1.183	2121	1.274	2928	1.359	3699	1.447	4662	1.534	5571	1.614	6564	1.689	7575	1.761	8529	1.832	9603
25.200	1.136	1636	1.238	2382	1.325	3165	1.405	4029	1.489	4980	1.572	5901	1.651	6975	1.726	7983	1.796	9087	1.866	10179
26.640	1.193	1818	1.294	2642	1.378	3402	1.454	4365	1.533	5310	1.611	6327	1.688	7398	1.762	8436	1.833	9597	1.900	10719
28.080	1.250	2065	1.350	2899	1.430	3744	1.504	4701	1.578	5652	1.653	6738	1.726	7821	1.799	8955	1.869	10101		
29.520	1.307	2309	1.406	3159	1.482	4101	1.554	5040	1.625	6081	1.695	7158	1.767	8250	1.837	9489	1.906	10611		
30.960	1.364	2550	1.460	3516	1.534	4452	1.605	5394	1.673	6495	1.739	7593	1.809	8754	1.877	9978				
32.400	1.422	2797	1.514	3867	1.587	4800	1.656	5832	1.722	6909	1.786	8049	1.852	9282						
33.840	1.479	3147	1.569	4209	1.641	5202	1.708	6264	1.772	7323	1.835	8565	1.898	9840						
35.280	1.535	3498	1.624	4548	1.695	5652	1.760	6693	1.824	7833	1.886	9081								
36.720	1.593	3849	1.678	4986	1.749	6105	1.813	7152	1.877	8376										
38.160	1.650	4203	1.732	5436	1.803	6555	1.868	7713												
39.600	1.706	4650	1.787	5883	1.858	7071														

Return Fan Performance, 50/48 UC-(V)/UP-(V) 220 (Option 183 & 184)

Air Flow Rate (m <sup>3</sup> /h)	Unit External Static Pressure (Pa)																			
	50		150		250		350		450		550		650		750		850		950	
	rpm	kW	rpm	kW	rpm	kW	rpm	kW	rpm	kW	rpm	kW	rpm	kW	rpm	kW	rpm	kW	rpm	kW
23.760	1.079	1376	1.183	2121	1.274	2928	1.359	3699	1.447	4662	1.534	5571	1.614	6564	1.689	7575	1.761	8529	1.832	9603
25.200	1.136	1636	1.238	2382	1.325	3165	1.405	4029	1.489	4980	1.572	5901	1.651	6975	1.726	7983	1.796	9087	1.866	10179
26.640	1.193	1818	1.294	2642	1.378	3402	1.454	4365	1.533	5310	1.611	6327	1.688	7398	1.762	8436	1.833	9597	1.900	10719
28.080	1.250	2065	1.350	2899	1.430	3744	1.504	4701	1.578	5652	1.653	6738	1.726	7821	1.799	8955	1.869	10101		
29.520	1.307	2309	1.406	3159	1.482	4101	1.554	5040	1.625	6081	1.695	7158	1.767	8250	1.837	9489	1.906	10611		
30.960	1.364	2550	1.460	3516	1.534	4452	1.605	5394	1.673	6495	1.739	7593	1.809	8754	1.877	9978				
32.400	1.422	2797	1.514	3867	1.587	4800	1.656	5832	1.722	6909	1.786	8049	1.852	9282						
33.840	1.479	3147	1.569	4209	1.641	5202	1.708	6264	1.772	7323	1.835	8565	1.898	9840						
35.280	1.535	3498	1.624	4548	1.695	5652	1.760	6693	1.824	7833	1.886	9081								
36.720	1.593	3849	1.678	4986	1.749	6105	1.813	7152	1.877	8376										
38.160	1.650	4203	1.732	5436	1.803	6555	1.868	7713												
39.600	1.706	4650	1.787	5883	1.858	7071														

### 13.8 - Compressor Softstarter

Compressor softstarter gradually increases the voltage to the compressor to have lower starting current. For mechanical and electrical connections of this option please refer to the certified wiring diagrams.

### 13.9 - Smoke Detector

The smoke detector is factory-fitted in return air side. If smoke is detected, there will be an alarm on the SmartVu control and the necessary actions will be taken. For mechanical and electrical connections of this option please refer to the certified drawings and wiring diagrams, and to the SmartVu Control IOM for further information.

### 13.10 - Fire Thermostat

The fire thermostat is factory-fitted in return air stream and checks the return air temperature. The factory setting is 70 °C and adjustable. If the return air temperature exceeds 70 °C, there will be an alarm on the SmartVu control and the necessary actions will be taken. For mechanical and electrical connections of this option please refer to the certified drawings and wiring diagrams, and to the SmartVu Control IOM for further information.

### 13.11 - Thermodynamic Energy Recovery (THR)

THR is considered as 3rd refrigerant circuit (Circuit C) with equal role as circuit A and circuit B which has exactly the same major system components. THR is always used with return fan option.

For mechanical and electrical connections of this option please refer to the certified drawings and wiring diagrams, and to the SmartVu Control IOM for further information.

Unit Model		Unit	025	035	045	055	065	075	090	105	125	140	160
Nominal Air Flow Rate		m <sup>3</sup> /h	4.205	5.886	7.568	9.250	10.463	11.533	12.500	14.500	19.375	20.981	23.274
THR Circuit Compressor Characteristics	Type		Scroll										
	No of Circuit / No of Compressor		1 / 1										
	Oil Type		PVE									POE	
	Oil Volume	l	1,06	1,57							3,30		
	Maximum Input Current	A	12	15			19			31			
Refrigerant Charge (R410A)		kg	3,6	4,6			5,4			6,6			
Refrigerant Charge (R454B)		kg	-	4,2			4,9			6,0			

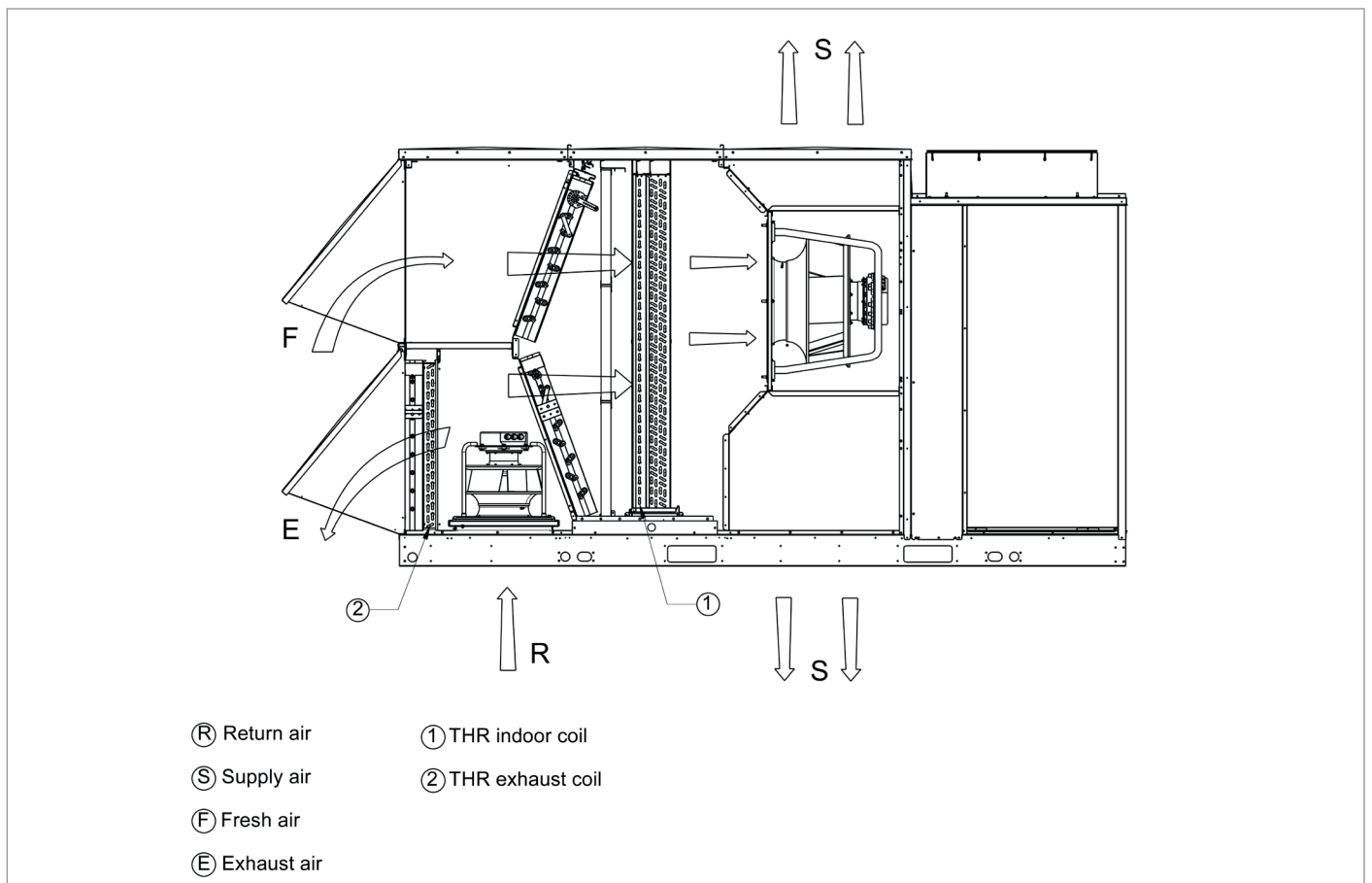

Fig. 15 - THR option

### 13.12 - Energy Recovery Module (ERM)

ERM is for connection to a ducted rooftop air system only. It is connected to the supply air and exhaust air sides of the unit.

It is equipped with an exhaust and fresh air protective hood and grilles to provide fresh air to the appliance inlet side and exhaust air from the appliance outlet side without the use of ductwork.

For mechanical and electrical connections of this option please refer to the certified drawings and wiring diagrams, and to the SmartVu Control IOM for further information.

### Rotary Energy Recovery Module (ERM)

#### Physical Data

**E:** Enthalpic type rotary heat exchanger;

**S:** Sorption type rotary heat exchanger

ERM Model	Unit	ERM3,0 E	ERM5,0 E	ERM7,1 E	ERM9,2 E	ERM11,4 E	ERM13,4 E	ERM17,4 E	ERM23,5 E	ERM29,6 E
Opt 172		ERM3,0 E	ERM5,0 E	ERM7,1 E	ERM9,2 E	ERM11,4 E	ERM13,4 E	ERM17,4 E	ERM23,5 E	ERM29,6 E
Opt 174		ERM3,0 S	ERM5,0 S	ERM7,1 S	ERM9,2 S	ERM11,4 S	ERM13,4 S	ERM17,4 S	ERM23,5 S	ERM29,6 S
<b>Weight</b>										
Enthalpic (E)	kg	194	222	248	286	354	368	374	485	567
Sorption (S)	kg	195	224	251	290	359	374	382	495	578
<b>Air Flow Rate</b>										
Maximum	m <sup>3</sup> /h	3.500	5.700	7.300	9.200	11.300	13.500	17.560	23.800	29.000
Minimum	m <sup>3</sup> /h	800	1.350	1.700	2.150	2.650	3.200	4.200	5.600	6.650
<b>Unit Thermal / Humidity Efficiency* for Enthalpic</b>										
Maximum Air Flow Rate	%	67,4 / 48,2	67,4 / 48,2	67,5 / 48,3	67,5 / 48,3	67,5 / 48,3	67,5 / 48,3	67,5 / 48,3	67,5 / 48,3	49,4 / 5,6
Minimum Air Flow Rate	%	81,9 / 65,8	81,8 / 65,5	81,9 / 65,7	81,9 / 65,7	81,9 / 65,6	81,9 / 65,8	81,8 / 65,5	81,9 / 65,6	76,9 / 24,3
<b>Unit Thermal / Humidity Efficiency* for Sorption</b>										
Maximum Air Flow Rate	%	69,4 / 58,0	69,4 / 58,0	69,4 / 58,0	69,4 / 58,0	69,4 / 58,0	69,4 / 58,0	69,4 / 58,0	69,4 / 58,0	55,6 / 30,7
Minimum Air Flow Rate	%	82,3 / 91,7	82,2 / 91,3	82,3 / 91,6	82,2 / 91,5	82,2 / 91,4	82,3 / 91,6	82,2 / 91,3	82,2 / 91,4	79,5 / 77,3
<b>Rooftop Model Compatibility</b>										
025		x								
035			x							
045				x						
055					x					
065						x				
075						x				
090						x				
105							x			
125								x		
140								x		
160									x	
190										x
220										x
<b>Energy Recovery Heat Exchanger</b>										
Motor Speed		10 - 12								
E	rpm	20								
S	rpm	IP 54								
Motor IP Class		IP 54								
Filter		ISO Coarse 65% Filter (G4 Cardboard Frame Filter)								
Filter Class (ISO 16890)		ISO Coarse 65% Filter (G4 Cardboard Frame Filter)								
Quantity	pcs	2	2	2	3	3	3	3	4	6
Filter Size	mm x mm x mm	565 x 685 x 50	565 x 685 x 50	620 x 800 x 50	456 x 800 x 50	565 x 940 x 50	565 x 940 x 50	565 x 940 x 50	1000 x 630 x 50	715 x 630 x 50
<b>Operating Limits</b>										
Maximum Outdoor Temperature	°C	+52								
Minimum Outdoor Temperature	°C	-20								
<b>Dimensions</b>										
Width	mm	1.220	1.220	1.320	1.520	1.770	1.770	1.770	2.070	2220
Length (With Fresh Air Hood)	mm	700 (1.040)	700 (1.040)	700 (1.115)	700 (1.115)	700 (1.205)	700 (1.205)	700 (1.205)	1000 (1.585)	1.100 (1.740)
Height	mm	1.485	1.485	1.715	1.715	2.000	2.000	2.000	2.155	2310

\*Thermal efficiency of supply air @ -10 °C outdoor air and @ 21 °C / 50% RH return air.

ERM Model	Unit									
Opt 176		ERM5.0 E	ERM7.0 E	ERM9.2 E	ERM11.2 E	ERM13.4 E	ERM17.4 E	ERM23.5 E	ERM28.6 E	ERM40.7 E
Opt 177		ERM5.0 S	ERM7.0 S	ERM9.2 S	ERM11.2 S	ERM13.4 S	ERM17.4 S	ERM23.5 S	ERM28.6 S	ERM40.7 S
<b>Weight</b>										
<b>Enthalpic (E)</b>	kg	222	221	286	298	368	374	485	566	767
<b>Sorption (S)</b>	kg	224	224	290	303	374	382	495	578	782
<b>Air Flow Rate</b>										
Maximum	m <sup>3</sup> /h	5.700	7.300	9.200	11.300	13.500	17.560	23.800	27.930	40450
Minimum	m <sup>3</sup> /h	1.350	1.700	2.150	2.650	3.200	4.200	5.600	6.600	9250
<b>Unit Thermal / Humidity Efficiency* for Enthalpic</b>										
Maximum Air Flow Rate	%	67.4 / 48.2	67.5 / 48.3	67.5 / 48.3	67.5 / 48.3	67.5 / 48.3	67.5 / 48.3	67.5 / 48.3	67.5 / 48.3	49.4 / 5.6
Minimum Air Flow Rate	%	81.8 / 65.5	81.9 / 65.7	81.9 / 65.7	81.9 / 65.6	81.9 / 65.6	81.8 / 65.5	81.9 / 65.6	81.9 / 65.6	76.9 / 24.3
<b>Unit Thermal / Humidity Efficiency* for Sorption</b>										
Maximum Air Flow Rate	%	69.4 / 58.0	69.4 / 58.0	69.4 / 58.0	69.4 / 58.0	69.4 / 58.1	69.4 / 58.0	69.4 / 58.0	69.4 / 58.0	55.6 / 30.6
Minimum Air Flow Rate	%	82.2 / 91.3	82.3 / 91.6	82.2 / 91.5	82.2 / 91.4	82.2 / 91.4	82.2 / 91.3	82.2 / 91.4	82.2 / 91.4	79.5 / 77.3
<b>Rooftop Model Compatibility</b>										
025		x								
035			x							
045				x						
055					x					
065						x				
075						x				
090							x			
105							x			
125								x		
140									x	
160									x	
190										x
220										x
<b>Energy Recovery Heat Exchanger</b>										
<b>Motor Speed</b>										
E	rpm	10 - 12								
S	rpm	20								
<b>Motor IP Class</b>		IP 54								
<b>Filter</b>		ISO Coarse 65% Filter (G4 Cardboard Frame Filter)								
Filter Class (ISO 16890)										
Quantity	pcs	2	2	3	3	3	3	4	6	6
Filter Size	mm x mm x mm	565 x 685 x 50	565 x 685 x 50	456 x 800 x 50	456 x 800 x 50	565 x 940 x 50	565 x 940 x 50	1000 x 630 x 50	715 x 630 x 50	830 x 780 x 50
<b>Operating Limits</b>										
Maximum Outdoor Temperature	°C	+52								
Minimum Outdoor Temperature	°C	-20								
<b>Dimensions</b>										
Width	mm	1,220	1,220	1,520	1,520	1,770	1,770	2,070	2,220	2,560
Length (With Fresh Air Hood)	mm	700 (1,040)	700 (1,040)	700 (1,115)	700 (1,115)	700 (1,205)	700 (1,205)	1000 (1,585)	1,100 (1,740)	1360(2090)
Height	mm	1,485	1,485	1,715	1,715	2,000	2,000	2,155	2,310	2,655

\*Thermal efficiency of supply air @ -10 °C outdoor air and @ 21 °C / 50% RH return air.

## Electrical Data

### Electrical Data

ERM Model	Unit									
Opt 172		ERM3.0 E	ERM5.0 E	ERM7.1 E	ERM9.2 E	ERM11.4 E	ERM13.4 E	ERM17.4 E	ERM23.5 E	ERM29.6 E
Opt 174		ERM3.0 S	ERM5.0 S	ERM7.1 S	ERM9.2 S	ERM11.4 S	ERM13.4 S	ERM17.4 S	ERM23.5 S	ERM29.6 S
<b>Power Circuit</b>		400-3-50								
Nominal Power Supply	V-ph-Hz	360-440								
Voltage Range	V	24 V, via Internal Transformer								
Control Circuit Supply		24 V, via Internal Transformer								
Maximum Input Power	W	90	90	90	90	90	180	180	180	220
Maximum Input Current	A	0.37	0.37	0.37	0.37	0.37	0.60	0.60	0.60	2.00
Maximum Supply Cable Size	mm <sup>2</sup>	1.50	1.50	1.50	1.50	1.50	1.50	1.50	1.50	1.50

### Electrical Data

ERM Model	Unit										
Opt 176		ERM5.0 E	ERM7.0 E	ERM9.2 E	ERM11.2 E	ERM13.4 E	ERM14.3 E	ERM17.4 E	ERM23.5 E	ERM28.6 E	ERM40.7 E
Opt 177		ERM5.0 S	ERM7.0 S	ERM9.2 S	ERM11.2 S	ERM13.4 S	ERM14.3 S	ERM17.4 S	ERM23.5 S	ERM28.6 S	ERM40.7 S
<b>Power Circuit</b>		400-3-50									
Nominal Power Supply	V-ph-Hz	360-440									
Voltage Range	V	24 V, via Internal Transformer									
Control Circuit Supply		24 V, via Internal Transformer									
Maximum Input Power	W	90	90	90	90	180	180	180	180	370	220
Maximum Input Current	A	0.37	0.37	0.37	0.37	0.60	0.60	0.60	0.60	1.11	2.00
Maximum Supply Cable Size	mm <sup>2</sup>	1.50	1.50	1.50	1.50	1.50	1.50	1.50	1.50	1.50	1.50

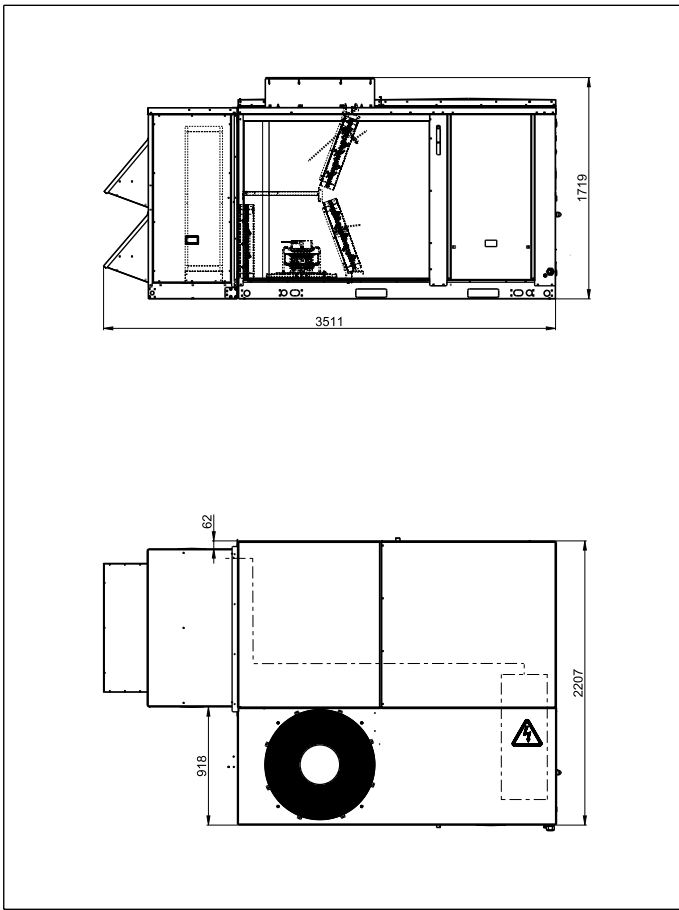

Fig. 16.1 -ERM 3.0 E / S; ERM 5.0 E / S; ERM 7.0 E / S and 50/48 UC-(V)/UP-(V) 025,035 Rooftop unit installation

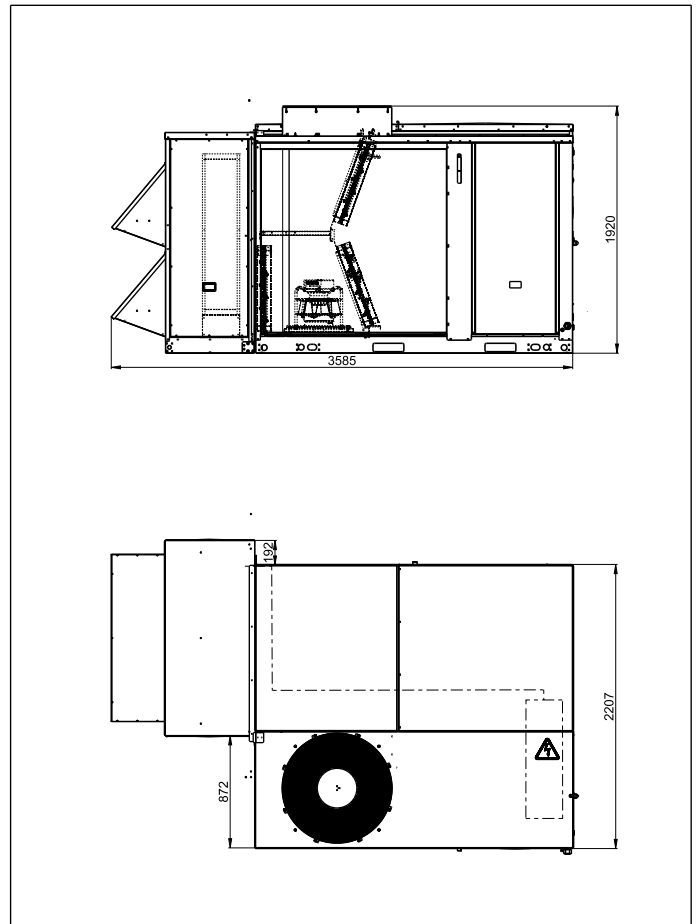

Fig. 16.3 -ERM 9.2 E / S; ERM 11.2 E / S and 50/48 UC-(V) / UP-(V) 055 Rooftop unit installation

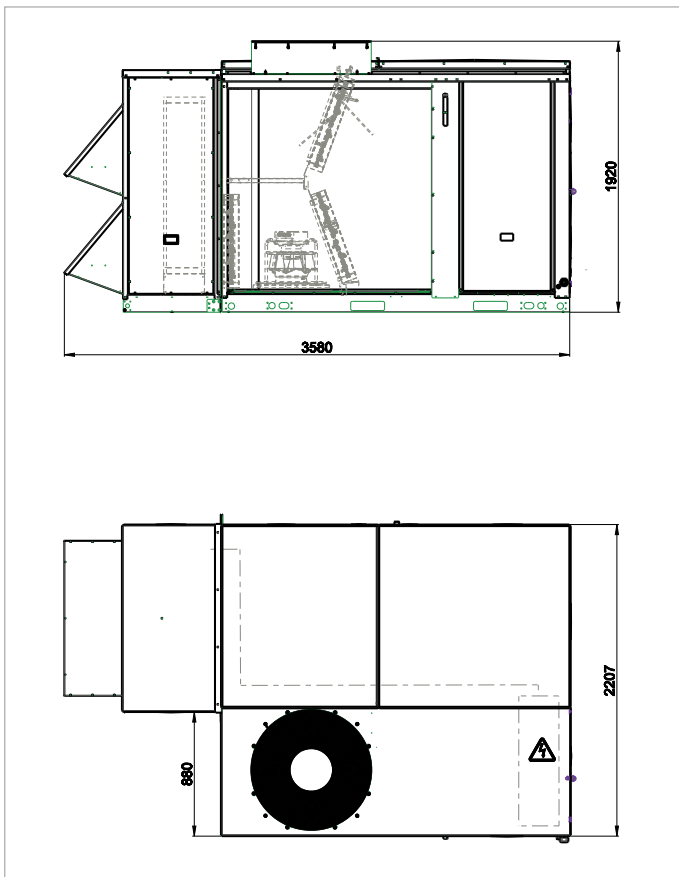

Fig. 16.2 -ERM 7.1 E / S; and 50/48 UC-(V)/UP-(V) 045,055 Rooftop unit installation

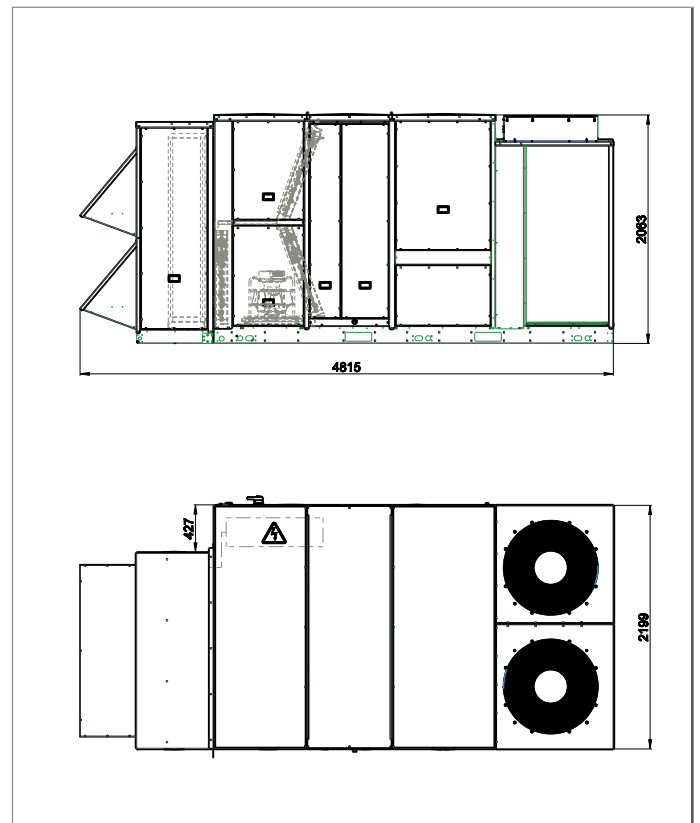

Fig. 16.4 - ERM 11.4 E / S; ERM 13.4 E / S; ERM 17.4 E / S and 50/48 UC-(V) / UP-(V) 065,075,090,105 Rooftop unit installation

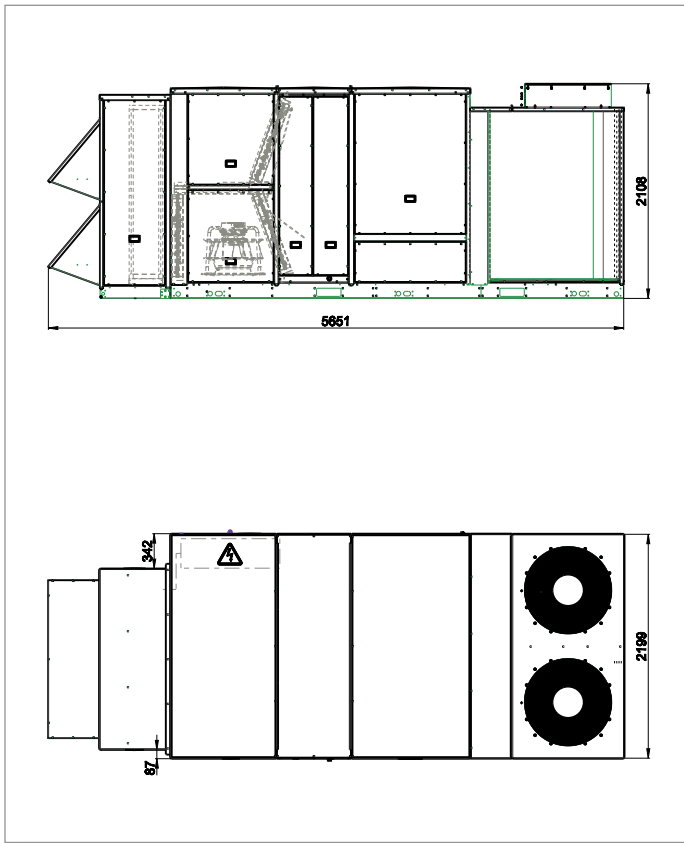

Fig. 16.5 -ERM 17.4 E / S and 50/48 UC-(V)/UP-(V) 125,140 Rooftop unit installation

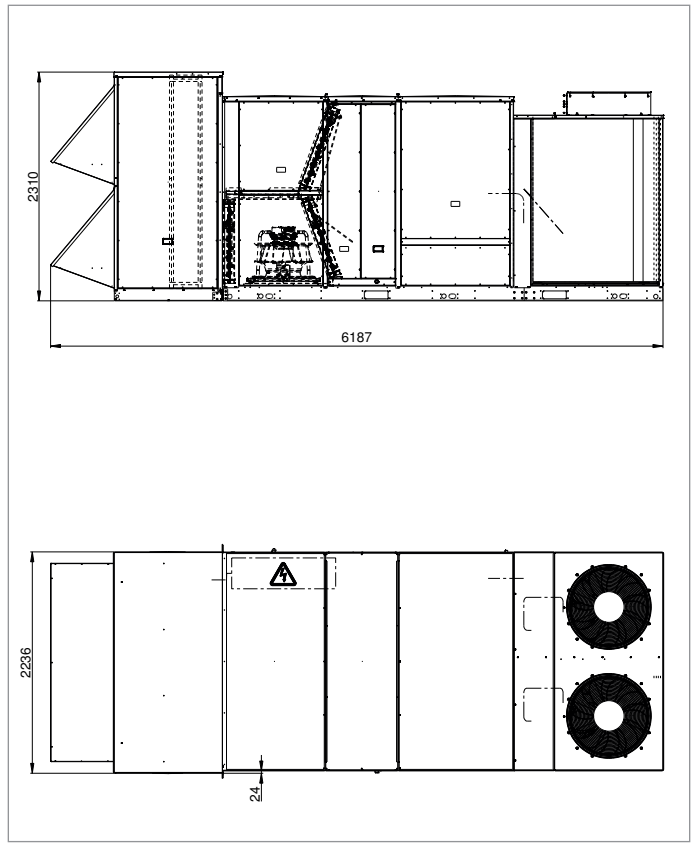

Fig. 16.7 -ERM 28.6 E / S and 50/48 UC-(V)/UP-(V) 140 Rooftop unit installation

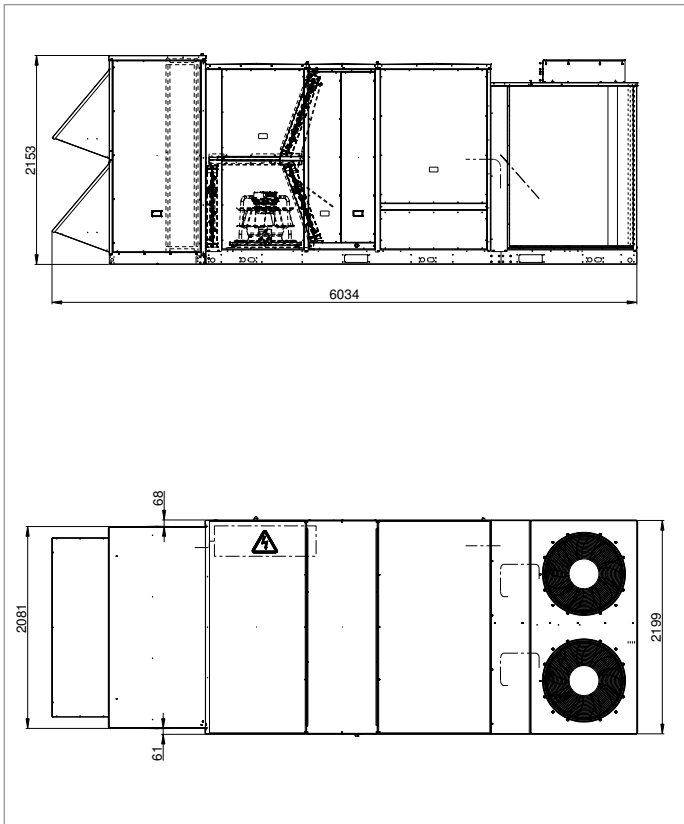

Fig. 16.6 -ERM 23.5 E / S and 50/48 UC-(V)/UP-(V) 125, Rooftop unit installation

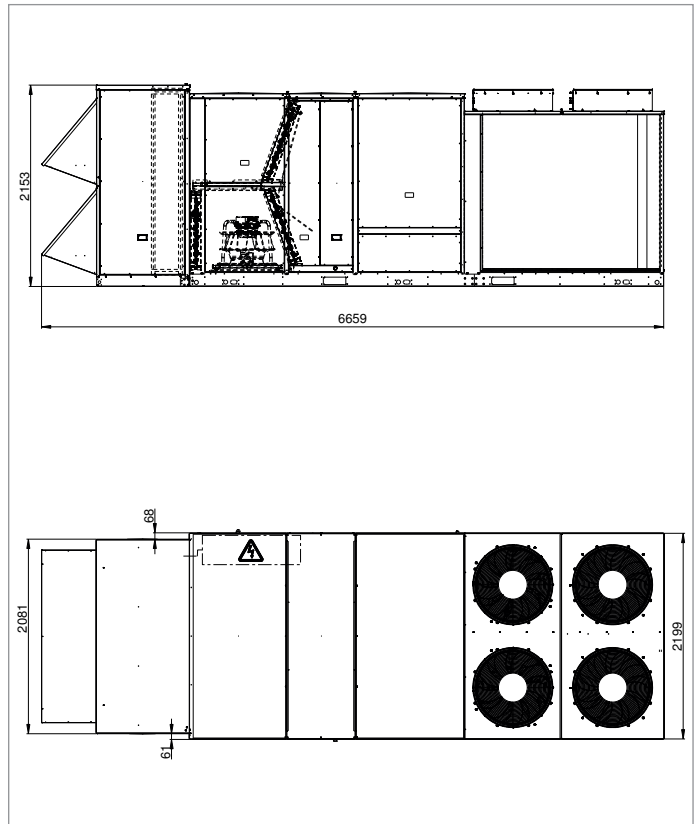

Fig. 16.8 -ERM 23.5 E / S and 50/48 UC-(V)/UP-(V) 160 Rooftop unit installation

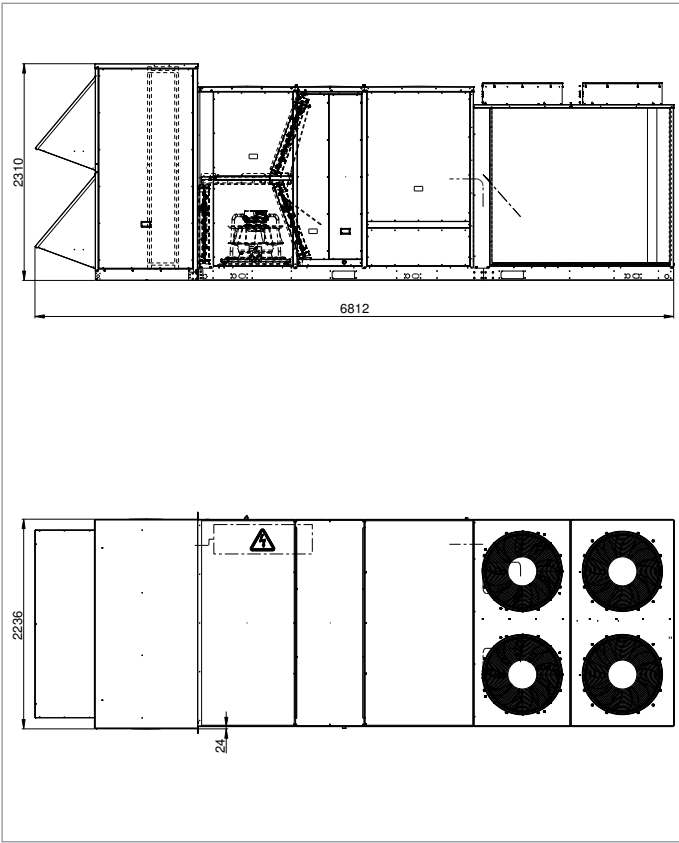

Fig. 16.9 -ERM 28.6 E / S and 50/48 UC-(V)/UP-(V) 160  
Rooftop unit installation

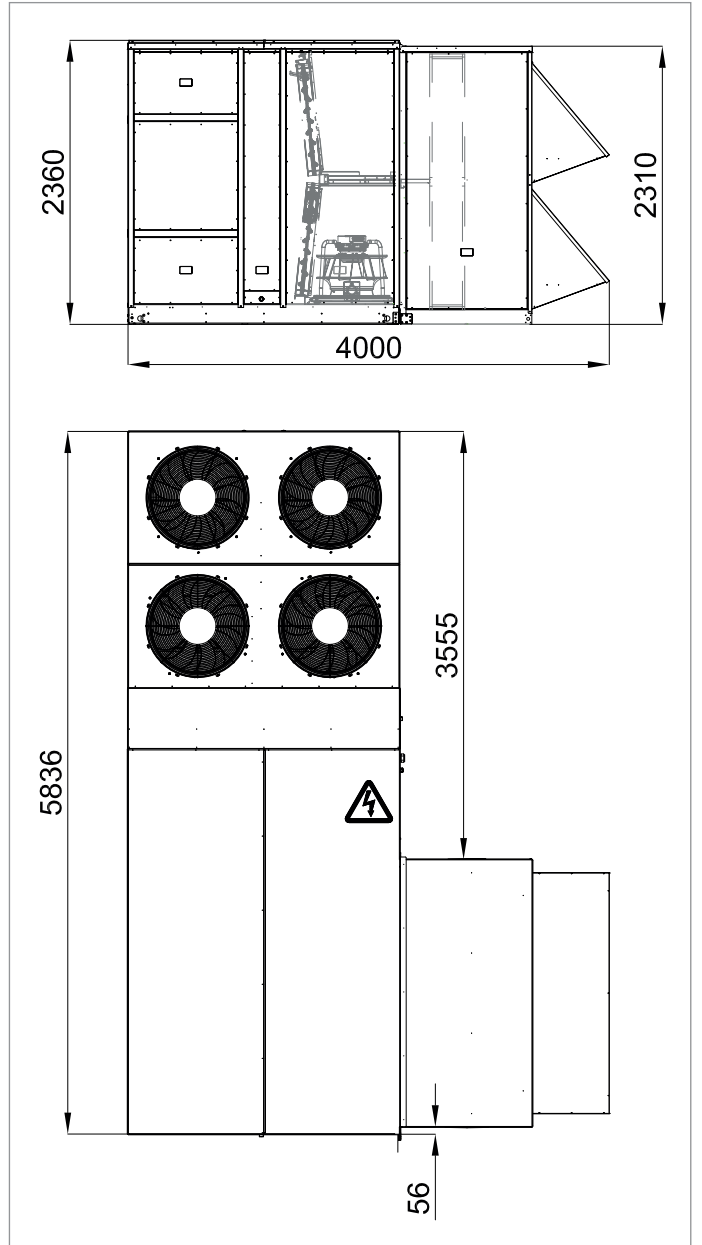

Fig. 16.10 -ERM 29.6 E / S and 50/48 UC-(V)UP-(V)  
190-220

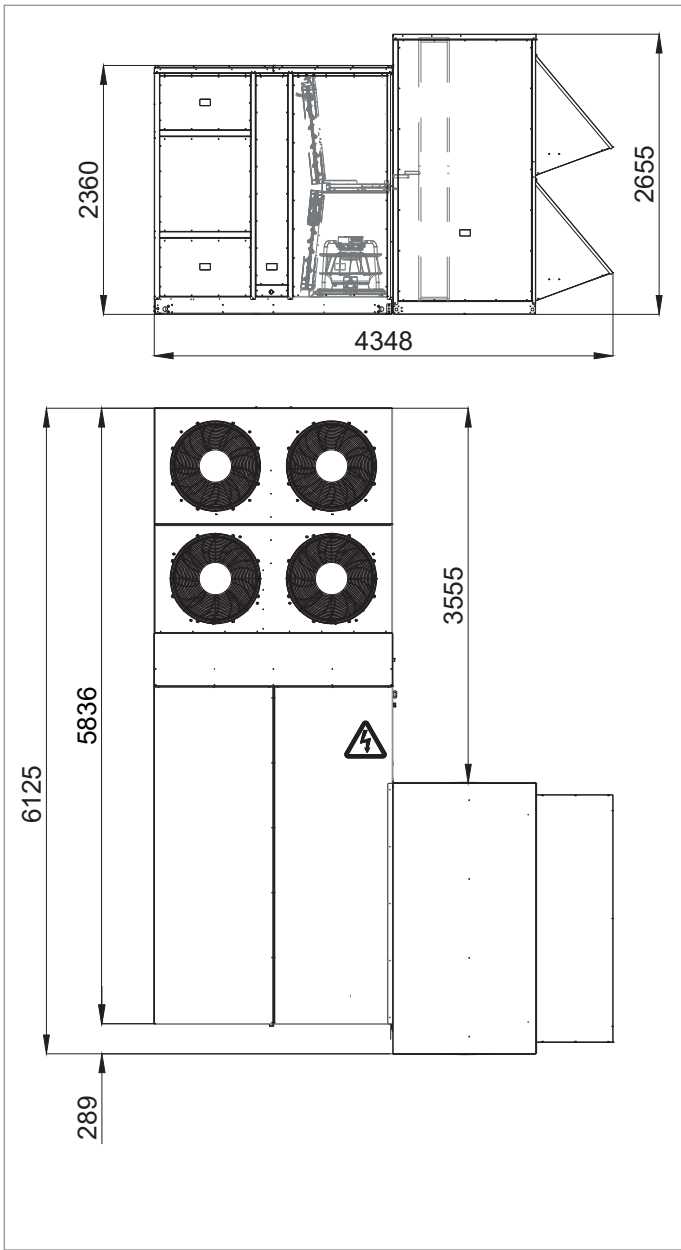

Fig. 16.11 -ERM 40.7 E / S and 50/48 UC-(V)UP-(V)  
190-220

The ERM support base must be level with the rooftop units support base

 Electrical connection factory-supplied



### 13.12.1 - ERM Installation

ERM should be installed directly to the unit. The ERM and Rooftop units are delivered with the some additional parts, as shown in following figure.

Fix the pulling sheets to ERM according to Fig.17.

Arrange the ERM position with Rooftop by using pulling sheets. Check the distances according to Fig. 16. Before getting closer the ERM to Rooftop, open heat wheel side panels and pass the ERM cables through Rooftop

electrical box side. After that get closer the ERM to Rooftop as shown in Fig. 17.

Install the side cover sheets between ERM and rooftop, as shown in Fig. 17, using self-tapping screws. Fix the Rooftop top cover sheet to ERM, as shown in Fig. 17, using self-tapping screws.

Apply mastic to the top and side surfaces between cover sheets and panels.

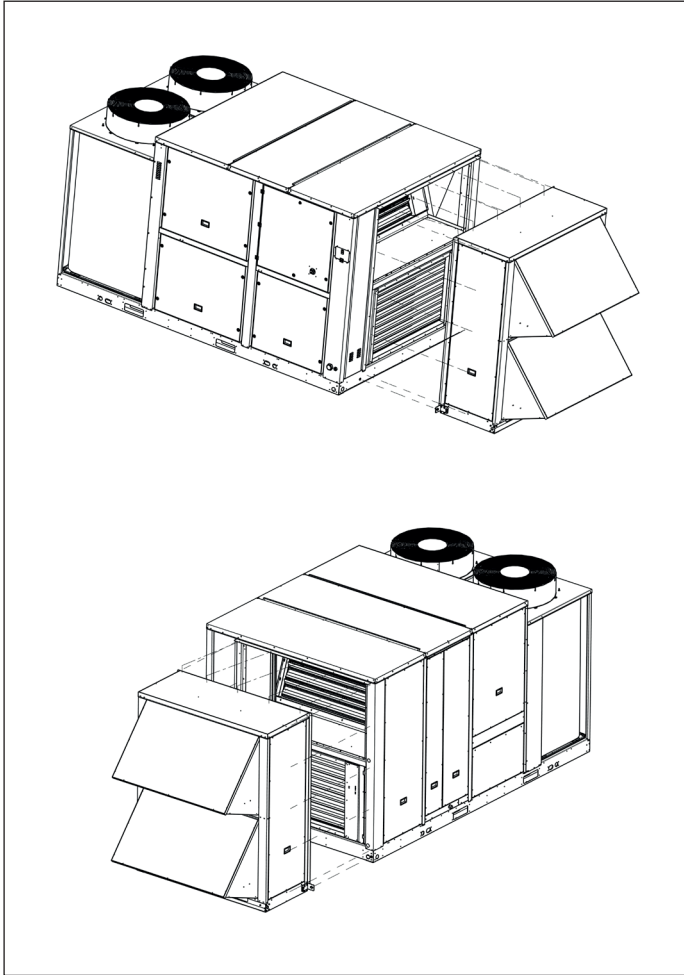

Fig. 17 - ERM Installation\_before

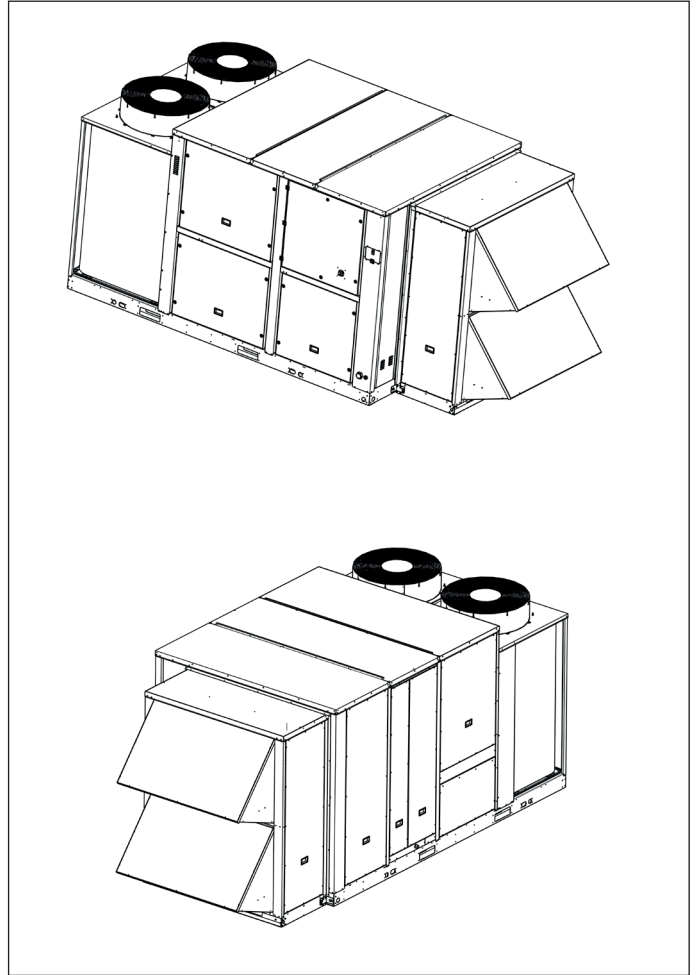
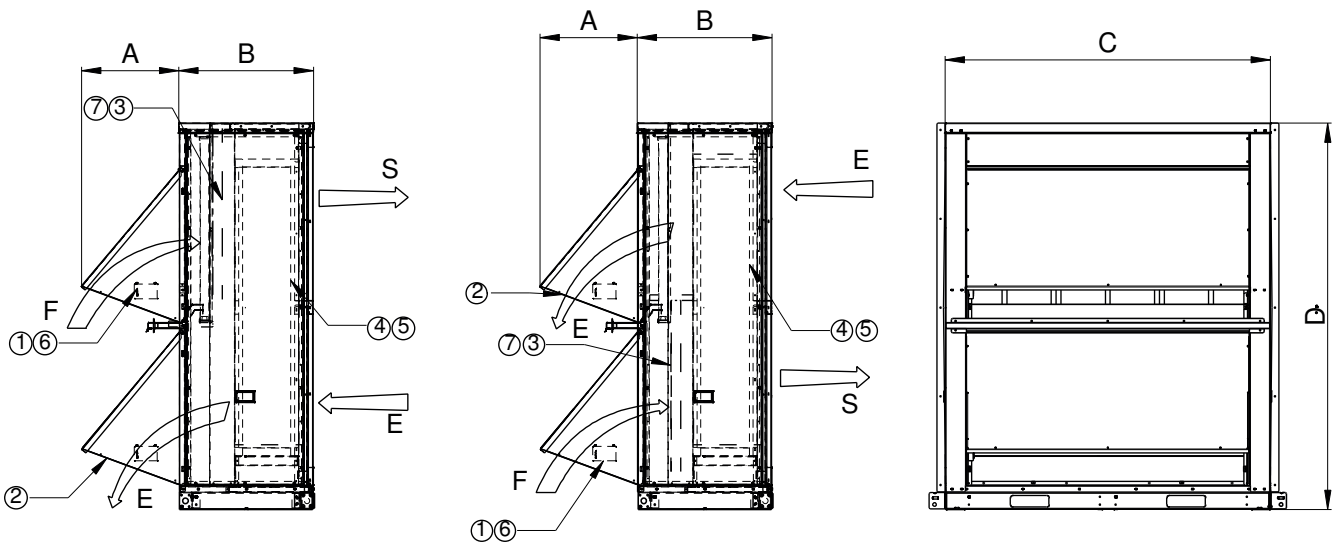

Fig. 18 - ERM Installation\_after



Unit size		A	B	C	D
ERM 3.0 E/S	mm	340	700	1220	1485
ERM 5.0 E/S	mm	340	700	1220	1485
ERM 7.0 E/S	mm	340	700	1220	1485
ERM 7.1 E/S	mm	415	700	1320	1715
ERM9.2 E/S	mm	415	700	1520	1715
ERM11.2 E/S	mm	415	700	1520	1715
ERM11.4 E/S	mm	505	700	1770	2000
ERM13.4 E/S	mm	505	700	1770	2000
ERM17.4 E/S	mm	505	700	1770	2000
ERM23.5 E/S	mm	585	1000	2070	2155
ERM28.6 E/S	mm	640	1100	2225	2310
ERM29.6 E/S	mm	640	1100	2225	2310
ERM40.7 E/S	mm	730	1360	2570	2655

- ① Fresh air hood
- ② Exhaust air hood
- ③ Filter
- ④ Energy recovery wheel
- ⑤ Motion sensor
- ⑥ Enthalpy sensor (OPT)
- ⑦ Dirty filter switch (OPT)
- ⓕ Fresh air
- ⓔ Exhaust air
- Ⓢ Supply air

Service clearances (mm)

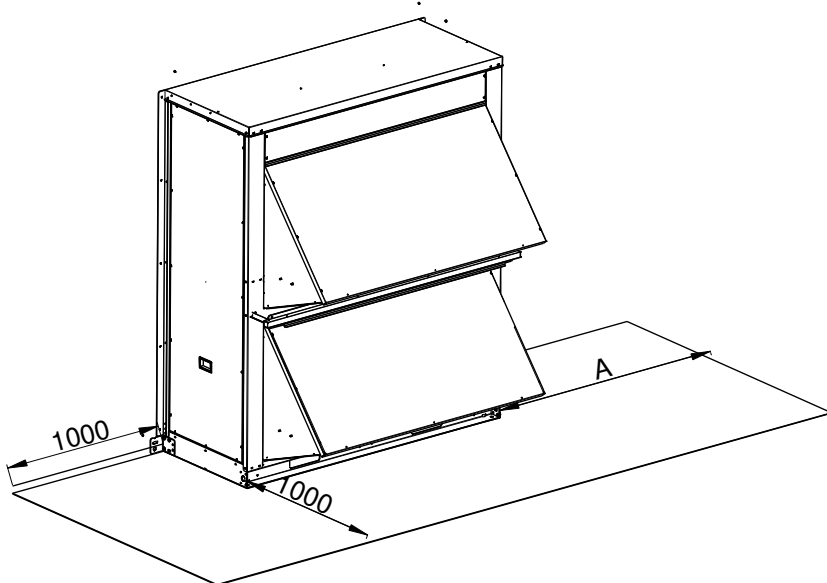

Unit size		A
ERM 3.0 E/S	mm	1000
ERM 5.0 E/S	mm	1200
ERM 7.0 E/S	mm	1200
ERM 7.1 E/S	mm	1200
ERM9.2 E/S	mm	1400
ERM11.2 E/S	mm	1500
ERM11.4 E/S	mm	1500
ERM13.4 E/S	mm	1700
ERM17.4 E/S	mm	1800
ERM23.5 E/S	mm	2100
ERM28.6 E/S	mm	2200
ERM29.6 E/S	mm	2200
ERM40.7 E/S	mm	2600

Fig. 19 - ERM dimensions & Clearance & Module Components

## ERM Operation

In the following table the component status is given according to the operating mode.

Mode	Wheel	Indoor Fan	Return Fan	Fresh Air Damper	Return Air Damper	Exhaust Air Damper
1 - Recirculation	Off	On	Off/On	100% Closed	100% Open	100% Closed
2 - Energy Recovery	On	On	Off/On	Minimum	Maximum	Minimum
3 - Free Cooling	Off	On	On	100% Open	100% Closed	100% Open

Step 1: Recirculation mode

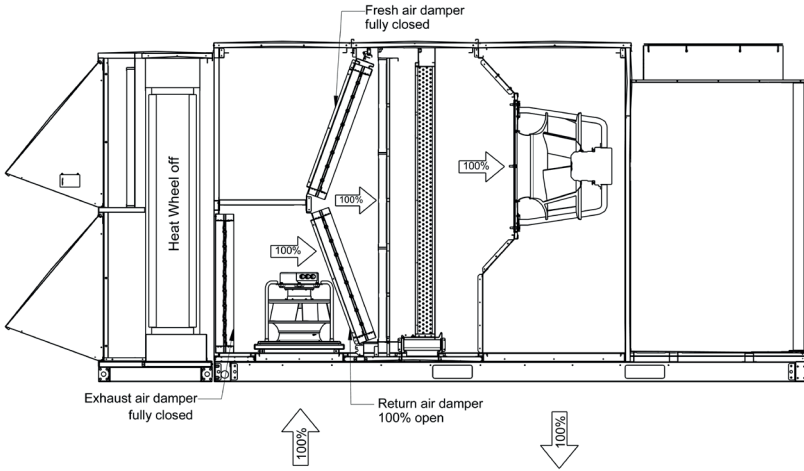

Step 2: Energy recovery mode

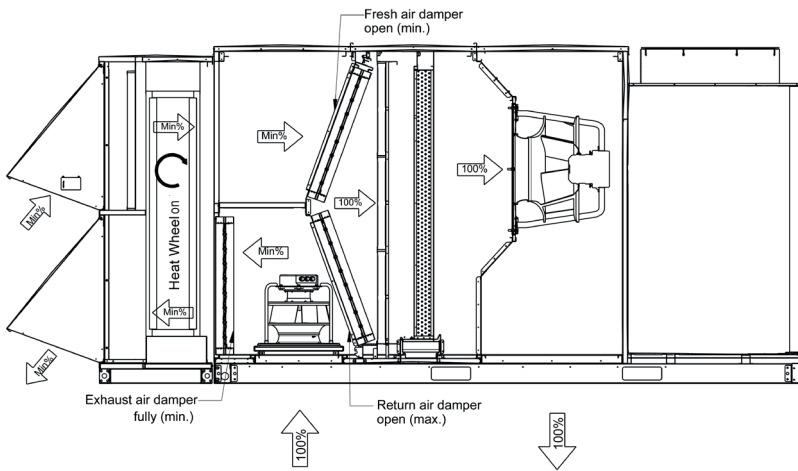

Step 3: Free-cooling mode

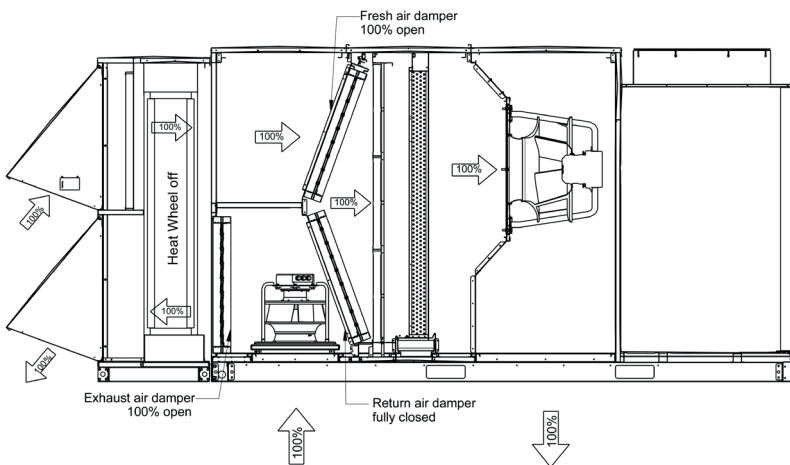

### 13.13 - Energy meter

The energy meter measures and displays minimum, maximum and total current, voltage and frequency for each phase and active & reactive power and power factor and total active & reactive energy consumption in Wh. For mechanical and electrical connections of this option please refer to the certified wiring diagrams.

### 13.14 - UV-C lamp

UV-C lamps are placed after the indoor coil to disinfect the air and coil. They are always ON and there are safety switches on related access panels to de-energize the lamps when the access panels are open. Lamps are designed for an effective life of 9,000 hours (approximately 1 year). Lamp must be changed at or before 9,000 hours to maintain designed efficacy. Lamps should be visually inspected and cleaned (if necessary) every 3-6 months to ensure proper function.

**WARNING:** Before installing fixture or performing maintenance or service on fixture, turn off main power switch to unit.

**CAUTION:** Never expose eyes or skin to ultraviolet light from any source.

For mechanical and electrical connections of this option please refer to the certified drawings and wiring diagrams

### 13.15 - Humidity Control

The humidity control is done by the SmartVu control via the input from the relative humidity sensor.

Please refer to the SmartVu IOM for the control logic. For dehumidification mode, one of the additional heating options must be selected in advance and for humidification mode, Field supplied humidifier is required. 24 VAC digital output is given for the humidifier. The room type relative humidity sensor is in the control box. Please refer to the wiring diagrams for the required connection and correct cable diameter selection criteria. Sensor locations vary with system and building specifics.

## 14 - ACCESSORIES

### 14.1 - Roofcurb

#### 14.1.1 - Vertical Roofcurb

This accessory is used to improve unit installation and facilitate vertical connection of the air supply and return ducts.

#### Installation

1. Check that the building structure is capable of supporting the unit operating weight.
2. Make the appropriate holes in the building ceiling so that the air supply and return ducts can be inserted.
3. Place the roofcurb accessory in the position selected for unit operation and ensure that the holes in the accessory coincide with those made in the ceiling.
4. The roofcurb accessory should be perfectly levelled to allow correct unit drainage.
5. The ducts can be connected to the roofcurb accessory before the unit is placed.
6. Assemble the unit on top of the roofcurb accessory ensuring that the unit supply and return air coincide with the accessory inlets. The unit and the accessory assembly should be as shown in Fig. 21.

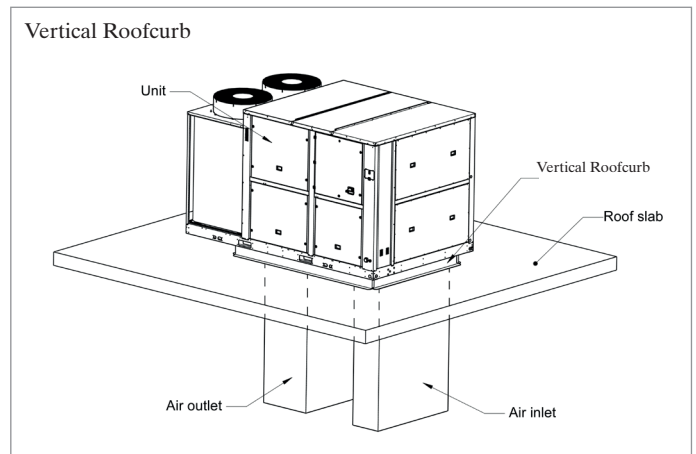

Fig. 21 - Vertical roofcurb

#### 14.1.2 - ERM with Vertical Roofcurb

When the unit is equipped with ERM option, there will be roofcurb extension to support ERM. This accessory is used to improve the unit with ERM installation and facilitate vertical connection of the air supply and return ducts.

#### Installation

1. Check that the building structure is capable of supporting the unit operating weight.
2. Make the appropriate holes in the building ceiling so that the air supply and return ducts can be inserted.
3. Place the roofcurb accessory in the position selected for unit operation and ensure that the holes in the accessory coincide with those made in the ceiling.
4. The roofcurb accessory should be perfectly levelled to allow correct unit drainage.
5. The ducts can be connected to the roofcurb accessory before the unit is placed.
6. The roofcurb extension for ERM (ERM curb) should also be fixed to the roofcurb before the unit is placed.
7. Assemble the unit on top of the roofcurb accessory ensuring that the unit supply and return air coincide with the accessory inlets.
8. ERM should be installed directly to the unit on the ERM curb.

The unit with ERM and the accessory assembly should be as shown in Fig. 22.

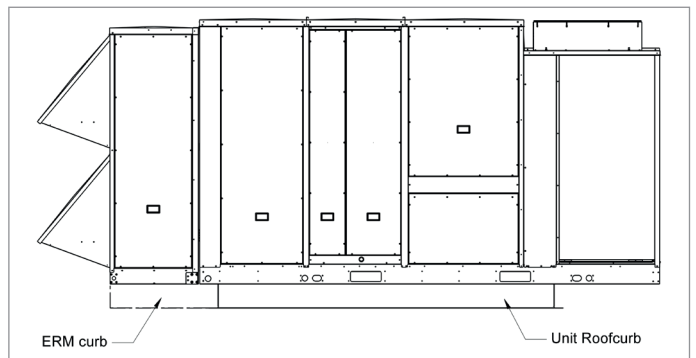

Fig. 22 – ERM with Vertical roofcurb

#### 14.2 - Leak Detection (R410A)

The refrigerant leak detector is factory-fitted after the indoor coil, before the indoor fan of the unit. If refrigerant leak is detected, there will be an alarm on the SmartVu control and the unit is shut down. For mechanical and electrical connections of this option please refer to the certified drawings and wiring diagrams, and to the SmartVu Control IOM for further information.

### 14.3 - Dirty Filter Detection

Dirty filter detection is controlled from the SmartVu control via the input from the differential pressure switch, checking the pressure drop across the filter. The factory setting is 250 Pa and it is adjustable. If the pressure drop across the filter exceeds 250 Pa, there will be an alarm on the SmartVu control and the necessary actions will be taken. For mechanical and electrical connections of this option please refer to the certified drawings and wiring diagrams, and to the SmartVu Control IOM for further information.

### 14.4 - CO<sub>2</sub> Sensor

The indoor air quality is controlled by the SmartVu control via the input from the CO<sub>2</sub> sensor, adjusting the economizer. Please refer to the SmartVu IOM for the control logic. The room air CO<sub>2</sub> sensor, together with the connector, is in the control box. Please refer to the wiring diagrams for the required connection and correct cable diameter selection criteria. Sensor locations vary with system and building specifics.

## 15 - STANDARD MAINTENANCE

Air conditioning equipment must be maintained by professional technicians, whilst routine checks can be carried out locally by specialized technicians.

All refrigerant charging, removal and draining operations must be carried out by a qualified technician and with the correct material for the unit. Any inappropriate handling can lead to uncontrolled fluid or pressure leaks.

**WARNING:** Before doing any work on the machine ensure that the power is switched off. If a refrigerant circuit is opened, it must be evacuated, recharged and tested for leaks. Before any operation on a refrigerant circuit, it is necessary to remove the complete refrigerant charge from the unit with a refrigerant charge recovery group.

In order to obtain maximum performance from the unit special attention should be paid to the following points:

- Electrical connections: The supply voltage should be within the limits permitted by the compressor.

Ensure that no faulty contacts exist in the terminal blocks, contactor boards, etc. Make sure that all the electrical connections are properly tightened, and that all the electrical components (contactors, relays, etc...) are firmly secured to the corresponding rails.

Pay special attention to the condition of the connecting cables between the control elements and the control box, and to that of the unit power supply cable. Check the starting and running consumptions are within the limits specified in the corresponding technical information.

- Drainage: Frequently check that the drain is not obstructed, and that the condensate pan is clean and level.
- Inlet filter: This should be cleaned periodically. The frequency depends on the purity of the entering air. The dirty filter option can be used to find out when the filter needs to be changed. A set of filters can be ordered as a spare part.
- Refrigerant circuit: Ensure that there is no leakage of refrigerant or oil from the compressor. Check that the high and low side operating pressures are normal. Make

sure that the coils are not dirty. Check for unusual compressor noise.

- Controls: Check the operation of all relays, high and low pressure transducers and the high-pressure switch, etc. Use the quick test function of the SmartVu control.

### 15.1 - Maintenance Program

All maintenance operations must be carried out by technicians who have been trained on Carrier products, observing all Carrier quality and safety standards.

### 15.2 - Maintenance Instructions

During the unit operating life the service checks and tests must be carried out in accordance with applicable national regulations.

If there are no similar criteria in local regulations, the information on checks during operation in annex C of standard EN 378-2 can be used.

External visual checks: annex A and B of standard EN 378-2.

Corrosion checks: annex D of standard EN 378-2. These controls must be carried out:

- After an intervention that is likely to affect the resistance or a change in use or change of high pressure refrigerant, or after a shutdown of more than two years. Components that do not comply, must be changed. Test pressures above the respective component design pressure must not be applied (annex B and D).
- After repair or significant modifications or significant system or component extension (annex B)
- After re-installation at another site (annexes A, B and D)
- After repair following a refrigerant leak (annex D). The frequency of refrigerant leak detection can vary from once per year for systems with less than 1% leak rate per year to once a day for systems with a leak rate of 35% per year or more. The frequency is in proportion with the leak rate.

NOTE: High leak rates are not acceptable. The necessary steps must be taken to eliminate any leak detected.

NOTE 2: Fixed refrigerant detectors are not leak detectors, as they cannot locate the leak.

### 15.3 - Level 1 Maintenance

See note in chapter 15.5. Simple procedures, can be carried out by the user on a weekly basis:

- Visual inspection for oil traces (sign of a refrigerant leak),
- Coil cleaning - see chapter 'Indoor/outdoor coils- level 1',
- Check for removed protection devices, and badly closed doors/covers,
- Check the unit alarm report when the unit does not work (see report in the SmartVu control manual),

- General visual inspection for any signs of deterioration,
- Verify the charge in the sight glass,
- Check that the temperature difference between the heat exchanger inlet and outlet is correct.
- Verify the unit operating parameters at 100% full load against the ones found during start-up.

#### 15.4 - Level 2 Maintenance

See note in chapter 15.5. This level requires specific know-how in the electrical, refrigeration and mechanical fields. It is possible that these skills are available locally: existence of a maintenance service, industrial site, specialized subcontractor.

The frequency of this maintenance level can be monthly or annually depending on the verification type.

In these conditions, the following maintenance operations are recommended.

Carry out all level 1 operations, then:

##### Electrical Checks

- At least once a year tighten the power circuit electrical connections (see table with tightening torques).
- Check and retighten all control/command connections, if required (see table with tightening torques).
- Remove the dust and clean the interior of the control boxes, if required.
- Check the status of the fuses, contactors, disconnect switches and capacitors.
- Replace the fuses every 3 years or every 15,000 hours (age-hardening).
- Check the presence and the condition of the electrical protection devices.
- Check the correct operation of all heaters.
- Check that no water has penetrated into the control box.

##### Mechanical Checks

- Check the tightening of the indoor and outdoor fan, compressor and control box fixing bolts.

##### Refrigerant Circuit

- Fully clean the condensers with a low-pressure jet and a bio-degradable cleaner (counter-current cleaning - see chapter 'Indoor/outdoor coils - level 2).
- Check the unit operating parameters at 100% full load and compare them with previous values.
- Carry out an oil contamination test. Replace the oil, if necessary.
- Check the operation of the high-pressure switches. Replace them if there is a fault.

- Check the fouling of the filter drier in cooling mode. Replace it if necessary.
- Keep and maintain a maintenance sheet, attached to each HVAC unit.

All these operations require strict observation of adequate safety measures: individual protection garments, compliance with all industry regulations, compliance with applicable local regulations and using common sense.

#### 15.5 - Level 3 (or Higher) Maintenance

See note in chapter 15.5. The maintenance at this level requires specific skills/approval tools and know-how and only the manufacturer, his representative or authorized agent are permitted to carry out these operations. These maintenance operations concern for example:

- A major component replacement (compressor, coils),
- Any intervention on the refrigerant circuit (handling refrigerant),
- Changing of parameters set at the factory (application change),
- Removal or dismantling of the HVAC unit,
- Any intervention due to a missed established maintenance operation,
- Any intervention covered by the warranty.

To reduce waste, the refrigerant and the oil must be transferred in accordance with applicable regulations, using methods that limit refrigerant leaks and pressure drops and with materials that are suitable for the products.

Any detected leaks must be repaired immediately.

The compressor oil that is recovered during maintenance contains refrigerant and must be treated accordingly.

Refrigerant under pressure must not be purged to the open air.

If a refrigerant circuit is opened, plug all openings, if the operation takes up to one day, or for longer periods charge the circuit with nitrogen.

**NOTE:** Any deviation or non-observation of these maintenance criteria will render the guarantee conditions for the HVAC unit null and void, and the manufacturer, Carrier, will no longer be held responsible.

## 15.6 - Tightening Torques for Main Electrical Connections

Component Screw Type	Designation in the Unit	Tightening Torque Value (Nm)
<b>Screw on Disconnect Switch (QS101)</b>		
3KD3030... (Size2, 100A)	L1/L2/L3	15...22
3KD3230... (Size2, 125A)	L1/L2/L3	15...22
3KD3430... (Size2, 160A)	L1/L2/L3	15...22
3KD3630... (Size2, 200A)	L1/L2/L3	15...22
3KD3830... (Size3, 250A)	L1/L2/L3	30...44
3KD4030... (Size3, 315A)	L1/L2/L3	30...44
3KD4230... (Size3, 400A)	L1/L2/L3	30...44
Screw PE	PE	4
Tunnel Terminal Screw, Fuse (3NP11..)	FU_	3,5...4,0
Tunnel Terminal Screw, Control Power Transformer	TC	2
Plug-in Socket (LZS..)	RL_	0,5...0,7
Compressor Phase & Earth Connection		3
<b>Power Contactors For Switching Motors</b>		
Contactora 3RT 10 1..		0,8...1,2
Contactora 3RT 10 2..		2,0...2,5
Contactora 3RT 10 3..	KM_	3,0...4,5
Contactora 3RT 10 4..		4...6
Contactora 3RT 20 1..		0,8...1,2
Contactora 3RT 20 2..		2,0...2,5
<b>Circuit Breakers</b>		
Disconnect 3RV 10 1..		0,8...1,2
Disconnect 3RV 10 2..		2,0...2,5
Disconnect 3RV 10 3..	QF_/QM_	3,0...4,5
Disconnect 3RV 10 4..		4...6
Disconnect 3RV 20 1..		0,8...1,2
Disconnect 3RV 20 2..		2,0...2,5
<b>Thermal Overload Relays</b>		
Thermal Relays 3RU 11 1..		0,8...1,2
Thermal Relays 3RU 11 2..	FR_	2,0...2,5
Thermal Relays 3RU 11 3..		3,0...4,5
Thermal Relays 3RU 11 4..		4...6
<b>Phase Order Relay</b>	MKC_	0,5

## 15.7 - Tightening Torques for the Main Bolts and Screws

Screw Type	Used For	Series	Model	Tightening Torque Value (Nm)
M8 Bolt	Compressor Mounting	UCV / UPV	025-035-065	11,0
M8 Bolt	Compressor Mounting	UCV / UPV	045-055-075-090-105-125	15,0
M8 Bolt	Compressor Mounting	UCV / UPV	140-160-190-220	21,0
M8 Bolt	Compressor Mounting, Single & Tandem	UC- / UP-	025-035-045-055-065-075 090-105-125-140-160-190	15,0
M8 Bolt	Compressor Mounting, Tandem	UC- / UP-	220	15 (A1, B1) / 16 (A2, B2)
M8 Nut	Compressor Mounting, Tandem	UC- / UP-	220	- / 55 (A2, B2)
M8 Bolt	Tandem Compressor Grommet Fixing	UC- / UP-	065-075-090-105	11,0
M8 Bolt	Tandem Compressor Grommet Fixing	UC- / UP-	055-125-140-160	15,0
M8 Bolt	Tandem Compressor Grommet Fixing	UC- / UP-	220	39,0
M8 Screw	Fan Scroll Fixing	All	All	18,0
Metal Screw	Sheet Metal Plates	All	All	4,2
M10 Bolt	Plug Fan Fixing	All	All	44,0

## 15.8 - Indoor/Outdoor Coils

We recommend, that finned coils are inspected regularly to check the degree of fouling. This depends on the environment where the unit is installed, and will be worse in urban and industrial installations and near trees that shed their leaves.

For coil cleaning, two maintenance levels are used:

### Level 1

- If the coils are fouled, clean them gently in a vertical direction, using a brush.
- Only work on coils with the fans switched off.
- For this type of operation switch off the HVAC unit if service considerations allow this.
- Clean coils guarantee optimal operation of your

This cleaning is necessary when the coils begin to become fouled. The frequency of cleaning depends on the season and location of the HVAC unit (ventilated, wooded, dusty area, etc.).

### Level 2

Clean the coil, using appropriate products.

We recommend TOTALINE products for coil cleaning: Part No. P902 DT 05EE: traditional cleaning method Part No. P902 CL 05EE: cleaning and degreasing.

The two cleaning products can be used for any of the following coil finishes: Cu/Cu, Cu/Al, Cu/Al with PoluAl, Aqua Aero, Blygold and/or Heresite protection.

These products have a neutral pH value, do not contain phosphates, are not harmful to the human body, and can be disposed of through the public drainage system.

Depending on the degree of fouling both products can be used diluted or undiluted.

For normal maintenance routines we recommend using 1 kg of the concentrated product, diluted to 10%, to treat a coil surface of 2 m<sup>2</sup>. This process can either be carried out using a high-pressure spray gun in the low-pressure position.

With pressurized cleaning methods care should be taken not to damage the coil fins. The spraying of the coil must be done:

- in the direction of the fins
- in the opposite direction of the air flow direction
- with a large diffuser (25-30°)
- at a minimum distance of 300 mm from the coil.

It is not necessary to rinse the coil, as the products used are pH neutral. To ensure that the coil is perfectly clean, we recommend rinsing with a low water flow rate. The pH value of the water used should be between 7 and 8.

**WARNING:** Never use pressurized water without a large diffuser. Do not use high-pressure cleaners for Cu/Cu and Cu/Al coils.

Concentrated and/or rotating water jets are strictly forbidden. Never use a fluid with a temperature above 45 °C to clean the air heat exchangers.

Correct and frequent cleaning (approximately every three months) will prevent 2/3 of the corrosion problems.

Protect the control box during cleaning operations.

## 15.9 - Refrigerant Volume

The unit must be operated in cooling mode to find out, if the unit charge is correct, by checking the actual subcooling. Following a small refrigerant leak a loss of refrigerant, compared to the initial charge will be noticeable in the cooling mode and affect the subcooling value obtained at the air heat exchanger (condenser) outlet, but it will not be noticeable in the heating mode.

**IMPORTANT:** It is therefore not possible to optimize the refrigerant charge in the heating mode after a leak. The unit must be operated in the cooling mode to check, if an additional charge is required.



50/48 UC-(V)/UP-(V) units use high-pressure R410A or R454B refrigerant (the unit operating pressure is above 40 bar, the pressure at 35°C air temperature is 50% higher than for R22). Special equipment must be used when working on the refrigerant circuit (pressure gauge, charge transfer, etc...)

### 15.10 - Servicing Recommendations

- Before replacing any of the elements in the cooling circuit, ensure that the entire refrigerant charge is removed from both the high and low pressure sides of the unit.
- The control elements of the cooling system are highly sensitive. If they need to be replaced, care should be taken not to overheat them with blowlamps whilst soldering. A damp cloth should be wrapped around the component to be soldered, and the flame directed away from the component body.
- Silver alloy soldering rods should always be used.
- If the total unit gas charge has to be replaced, the quantity should be as given on the nameplate and the unit should be properly evacuated beforehand.
- During unit operation all panels should be in place, including the electrical box access panel.
- If it is necessary to cut the lines of the refrigerant circuit, tube cutters should always be used and never tools which produce burrs. All refrigerant circuit tubing should be of copper, specially made for refrigeration purposes.

### 15.11 - Final Recommendations

The unit you have purchased has undergone strict quality control procedures before leaving the factory.

All components, including the control systems and electrical equipment, etc., are certified by our Quality

Control Department and tested under the harshest possible operating conditions in our laboratories. However, after leaving the factory, it is possible that one or more of these elements may be damaged due to causes beyond our control. In such an event, the user should not work on any of the internal components, or subject the unit to operating conditions which are not specified in this manual, since serious damage may result and the guarantee would be invalidated. Repair and maintenance work should always be left to the installer.

All recommendations concerning unit installation are intended to be as a guideline. The installer should carry out the installation according to the design conditions and should comply with all applicable regulations for air conditioning and refrigeration installations.

**NOTE:** The manufacturer does not accept responsibility for any malfunctions resulting from misuse of the equipment.

### 15.12 - Troubleshooting Chart

A list of possible faults, as well as the probable cause and suggested solutions is shown in the table below. In the event of a unit malfunction it is recommended to disconnect the power supply and ascertain the cause.

Symptoms	Cause	Remedy
Unit does not start	No power supply Main switch open Low line voltage A protection has tripped Contactor stuck open Compressor failure	Connect power supply Close main unit disconnect switch Check voltage and remedy the deficiency Reset Check and if necessary replace contactor Check and if necessary replace compressor
Unit starts and stops frequently	Defective compressor contactor Defective compressor Refrigerant losses	Check and if necessary replace contactor Check and if necessary replace compressor Check and add the necessary quantity
Unit continuously cuts out at low saturated suction temperature	<b>Cooling unit/heat pump</b> Defective low pressure transducer Refrigerant losses Indoor/outdoor fan does not operate	Check and if necessary replace low pressure transducer Check and add the necessary quantity Check fan motor
Unit continuously cuts out at saturated discharge temperature	<b>Cooling unit/heat pump</b> Defective high pressure transducer Blocked filter drier Indoor/outdoor fan does not operate	Check and if necessary replace pressure transducer Check and if necessary replace filter Check fan motor
Abnormal system noise	Noisy compressor Badly fitting panels	Check and change if necessary Install correctly
Compressor loses oil	Leak in system	Repair leak
Water loss	Defective drainage connections	Check and tighten if necessary

**IMPORTANT:** Following any operation on the appliance which has necessitated removal and replacement of any parts, the appliance shall be recommissioned in accordance with the Commissioning section of these instructions.

**16 - START-UP CHECKLIST FOR 50/48 UC-(V)/UP-(V) ROOFTOP UNITS (USE FOR JOB FILE)**

**Preliminary Information**

Job name: .....

Location: .....

Installing contractor: .....

Distributor: .....

Start-up preformed by: ..... Date: .....

**Equipment**

Model 50/48 UC-(V)/UP-(V): ..... S/N .....

**Compressors**

**Circuit A**

1. Model No . .....

Serial No . .....

2. Model No .....

Serial No .....

**Circuit B**

1. Model No .....

Serial No . .....

2. Model No .....

Serial No . .....

**Circuit C (THR Option)**

1. Model No . .....

Serial No . .....

Additional options and accessories .....

**Preliminary Equipment Check**

Is there any shipping damage? ..... If so, where? .....

Will this damage prevent unit start-up? .....

- Unit is level in its installation
- Power supply agrees with the unit name plate
- Electrical circuit wiring has been sized and installed properly Unit ground wire has been connected
- Electrical circuit protection has been sized and installed properly All terminals are tight
- All cables and thermistors have been inspected for crossed wires

**Unit Start-up**

- Oil level is correct
- Compressor crankcase heaters have been energised for 12 hours
- Unit has been leak checked (including fittings)
- Locate, repair, and report any refrigerant leaks

.....  
.....  
.....

Check voltage imbalance: AB ..... AC ..... BC .....

Average voltage = ..... (see installation instructions)

Maximum deviation = ..... (see installation instructions)

Voltage imbalance = ..... (see installation instructions)

Voltage imbalance is less than 2%

**WARNING:** Do not start unit if voltage imbalance is greater than 2%. Contact local power company for assistance.

All incoming power voltage is within rated voltage range

**Carry out the QUICK TEST function (see 50/48 UC-(V)/UP-(V) SmartVu Control IOM:**

**Re-enter the setpoints (see controls section)**

**To start up the unit**

**Once all checks have been made, start the unit in the “LOCAL ON” position.**

Unit starts and operates properly

**Temperatures and pressures**

**WARNING:** Once the machine has been operating at 100% full load for a while and the temperatures and pressures have stabilized, record the following:

- Entering air temperature.....
- Leaving air temperature .....
- Ambient temperature.....
- Circuit A suction pressure.....
- Circuit B suction pressure .....
- Circuit A discharge pressure.....
- Circuit B discharge pressure .....
- Circuit A suction temperature.....
- Circuit B suction temperature.....
- Circuit A discharge temperature .....
- Circuit B discharge temperature.....
- Circuit A liquid line temperature .....
- Circuit B liquid line temperature .....
- Circuit C suction pressure (THR option).....
- Circuit C discharge pressure (THR option).....
- Circuit C suction temperature (THR option).....
- Circuit C discharge temperature (THR option).....
- Circuit C liquid line temperature (THR option).....

**ACCESSORIES**

.....  
.....

**17 - GAS HEATING SECTION**

**Gas heater**

Size:.....  
.....

Serial No.: .....

Pipe size: .....

Gas type: G .....

Line pressure: ..... mbar

Power input: .....W      Flue temp.: ..... °C

NOX:.....mg/kWh      CO ppm: .....%

**NOTE:** Complete this start-up list at the time of installation.

## AT UYGUNLUK BEYANI

## EC DECLARATION OF CONFORMITY

**ALARKO - CARRIER SAN. VE TİC. A.Ş.**GOSB - Gebze Organize Sanayi Bölgesi, Şahabettin Bilgisu Cad. 41480  
Gebze – KOCAELİ / TURKEY

Aşağıda tanımlanmış olan ekipmanlar için **Makina Emniyeti Yönetmeliği 2006 / 42 / AT**' nin uygulanabilen gerekliliklerinin yerine getirildiğini ve sorumluluğun alınmış olduğunu beyan ederiz.

Aşağıda tanımlanan ürünler iç üretim kontrollerine bağlı olarak **Firmamız** tarafından kontrol edilmiştir. Bu deklarasyon makinanın teslimat durumundaki son şekliyle geçerlidir. Son kullanıcı tarafından ürün üzerinde yapılacak herhangi bir modifikasyonda, bu deklarasyon geçerliliğini yitirmiş olacaktır.

ÜRÜN TANIMI :**Paket Tip Yalnız Soğutma, Isı Pompalı ve Gaz Isıtımlı Çatı Klimaları**MODEL/ TİP :**48/50 UC-(V) 025-035-045-055-065-075-090-105-125-140-160-190-220**  
**48/50 UP-(V) 025-035-045-055-065-075-090-105-125-140-160-190-220**YÖNETMELİKLER:**Makina Emniyeti Yönetmeliği 2006 / 42 / AT**  
**Alçak Gerilim Yönetmeliği 2014 / 35 / AB**  
**Elektromanyetik Uyumluluk Yönetmeliği 2014 / 30 / AB**  
**Basıncılı Kaplar Yönetmeliği 2014 / 68 / AB**  
**Gaz Ekipmanlar Yönetmeliği 2016 / 426 / AB ( 48 seri sadece )**  
**Eko-tasarım Yönetmeliği 2009 / 125 / EC**UYGULANAN UYUMLAŞTIRILMIŞ STANDARTLAR:**EN ISO 12100:2010, EN 60204-1:2018, EN 61000-6-2:2005/AC:2005, EN 61000-6-3:2007/A1:2011/AC:2012, EN 378-2:2016, EN 12263:1998, EN 14276-1:2020, EN 14276-2:2020, EN 14511-1:2022, EN 14511-3:2022, EN 14511-4:2022, EN 14825:2022, EN 1020:2009(48 series only)****TEKNİK DOSYAYI HAZIRLAMAKLA YETKİLİ OLAN KİŞİ ADI VE ADRESİ –**  
**NAME AND ADDRESS OF THE PERSON AUTHORISED TO COMPILE THE TECHNICAL FILE:****AD\_SOYAD / NAME\_SURNAME**  
**ADRESİ- ADDRESS****: Mr. Barış AKGÜL**  
**: GOSB - Gebze Organize Sanayi Bölgesi, Şahabettin Bilgisu**  
**Cad. 41480 KOCAELİ / TURKEY****İMALATÇI ADINA - SIGNED ON BEHALF OF THE MANUFACTURER****AD\_SOYAD- NAME\_SURNAME**  
**GÖREV - POSITION**  
**YER /TARİH – PLACE / DATE**  
**İMZA – SIGNATURE****: Mr.Murat Çopur**  
**: Genel Müdür Yrd./Fabrikalar – Deputy Gen.Manager/Factories**  
**: Kocaeli / 05-06-2024**  
**:**









The quality management system of this product's assembly site has been certified in accordance with the requirements of the **ISO 9001** standard (latest current version) after an assessment conducted by an authorized independent third party.

The environmental management system of this product's assembly site has been certified in accordance with the requirements of the **ISO 14001** standard (latest current version) after an assessment conducted by an authorized independent third party.

The occupational health and safety management system of this product's assembly site has been certified in accordance with the requirements of the **ISO 45001** standard (latest current version) after an assessment conducted by an authorized independent third party.

The security management system of this product's assembly site has been certified in accordance with the requirements of the **ISO 27001** standard (latest current version) after an assessment conducted by an authorized independent third party.

Please contact your sales representative for more information.

Order No: 10855, 09.2024. Supersedes Order No: 13010, 12.2022.

Manufacturer reserves the right to change any product specifications without notice.